

THE WORKSHOP COMPANION™

JOINING WOOD

TECHNIQUES FOR BETTER WOODWORKING

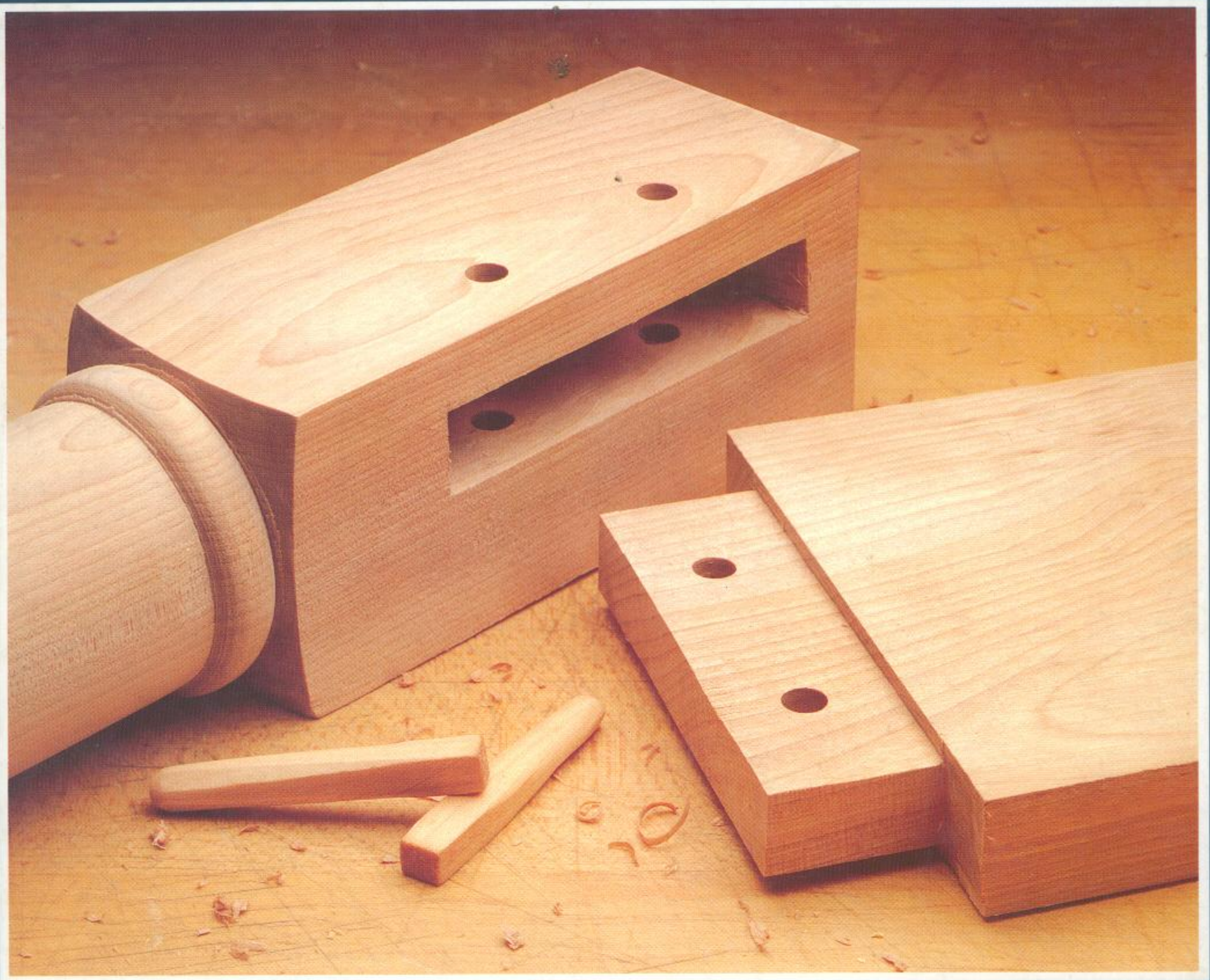

NICK ENGLER

THE WORKSHOP COMPANION™

TIPS AND TECHNIQUES FOR THE WOODWORKER

Basic Woodworking Joints at Your Fingertips!

Possibly THE most important task in woodworking is joinery — attaching one board to another. It can also be a thoroughly confusing task. There are countless woodworking joints — rabbets, dadoes, dovetails, mortises and tenons — which do you choose? How do you make it? In *Joining Wood*, author/craftsman Nick Engler simplifies this complex subject, showing how master woodworkers use good sense and a few elementary rules of thumb to produce strong, durable designs. He also demonstrates how to make dozens of popular woodworking joints, from a simple miter to an elegant through dovetail, using just five basic cuts!

The techniques required to make each joint are clearly illustrated, step by step, in over 200 drawings and photographs. There are also plenty of shop-tested tips, ingenious jigs and fixtures, useful charts, and inside information to help hone your joinery skills.

More importantly, *Joining Wood* shows you *practical applications* for much of this valuable information. There are complete plans and instructions for popular projects that combine many of the joinery techniques explained in the text:

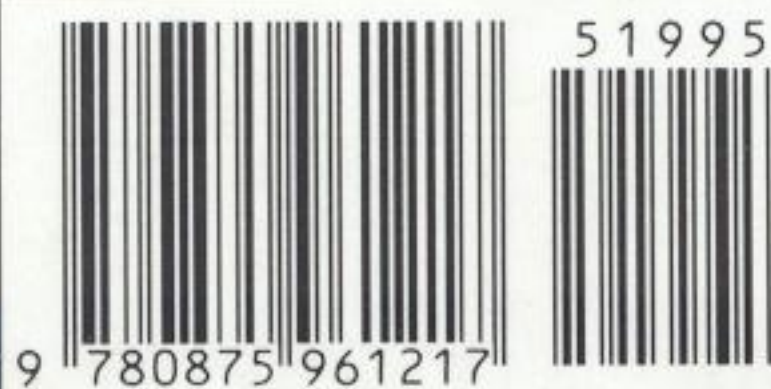

- A *cabinetmaker's workbench* joins a mortise-and-tenon frame to a butcher-block top to make a useful table that is a pleasure to look at and work on.
- A *cut-off jig* for your table saw makes it easy to cut precise, close-fitting joints.
- A country *pewter rack* is joined with simple dadoes and rabbets.
- A *half-moon bench* is assembled with traditional dovetails and wedged mortises and tenons.
- A *miniature chest of drawers* combines stopped grooves, lock joints, reinforced miters, and haunched mortises and tenons.



ISBN 0-87596-121-5

Copyright © 1992 by Bookworks, Inc.
Cover photo copyright © 1992 by Rodale Press, Inc.

All rights reserved. No part of this publication may be reproduced or transmitted in any form or by any means, electronic or mechanical, including photocopy, recording, or any other information storage and retrieval system, without the written permission of the publisher.

Printed in the United States of America on acid-free , recycled paper 

If you have any questions or comments concerning this book, please write:

Rodale Press
Book Reader Service
33 East Minor Street
Emmaus, PA 18098

About the Author: Nick Engler is an experienced woodworker, writer, and teacher. For many years, he was a luthier making traditional American musical instruments before he founded *Hands On!* magazine. Today, he contributes to other how-to magazines and has published over 20 books on the wood arts. He teaches woodworking at the University of Cincinnati.

Series Editor: Jeff Day
Editors: Roger Yepsen
 Kenneth Burton
Copy Editor: Sarah Dunn
Graphic Designer: Linda Watts
Graphic Artists: Mary Jane Favorite
 Chris Walendzak
Photographer: Karen Callahan
Cover Photographer: Mitch Mandel
Proofreader: Hue Park
Typesetting by Computer Typography, Huber Heights, Ohio
Interior and endpaper illustrations by Mary Jane Favorite
Produced by Bookworks, Inc., West Milton, Ohio

Library of Congress Cataloging-in-Publication Data

Engler, Nick.
Joining wood/by Nick Engler.
p. cm. — (The workshop companion)
Includes index.
ISBN 0-87596-121-5 hardcover
1. Woodwork. 2. Timber joints. 3. Joinery. I. Title
II. Series.
TT185.E54 1992
684'.08—dc20

91-36032
CIP

The author and editors who compiled this book have tried to make all the contents as accurate and as correct as possible. Plans, illustrations, photographs, and text have all been carefully checked and cross-checked. However, due to the variability of local conditions, construction materials, personal skill, and so on, neither the author nor Rodale Press assumes any responsibility for any injuries suffered, or for damages or other losses incurred that result from the material presented herein. All instructions and plans should be carefully studied and clearly understood before beginning construction.

Special Thanks to:

Sotheby Parke Bernet Inc.
New York, New York
Wertz Hardware
West Milton, Ohio

THE WORKSHOP COMPANION™

JOINING WOOD

TECHNIQUES FOR BETTER WOODWORKING

by Nick Engler



Rodale Press
Emmaus, Pennsylvania

CONTENTS

TECHNIQUES

1. **A Joinery Primer** 2
 - Types of Joints 3
 - The Purpose of Joinery 4
 - Tangential/Radial Movement of Common Wood Species* 9
 - The Value of Simplicity 16

2. **Selecting Tools and Preparing Materials** 17
 - Joinery Tools 18
 - Preparing the Wood 24

3. **Simple Joints** 27
 - Five Cuts 28
 - Basic Woodworking Cuts* 28
 - Cut-Off Jig* 32
 - Compound Miter Angles* 39
 - Miter Jig* 40
 - Using a Router Plane* 44
 - Examples of Simple Joinery* 47

4. **Reinforced Joints** 48
 - Four Ways to Reinforce 49
 - Splined Miter Jig* 56

5. The Versatile Mortise and Tenon	61
Mortise and Tenon Tips	62
Mortising Fence	67
Using a Mortiser	69
Tenoning Jig	72
Variations	74
Pegging a Mortise-and-Tenon Joint	79

6. Interlocking Joints	80
Increasing Gluing Surface	81
Finger-Joint Jig	84
Dovetail Aids	90

PROJECTS

7. Pewter Rack	96
8. Miniature Chest of Drawers	101
9. Half-Moon Bench	108
10. Cabinetmaker's Workbench	111

Index	122
-------	-----

TECHNIQUES

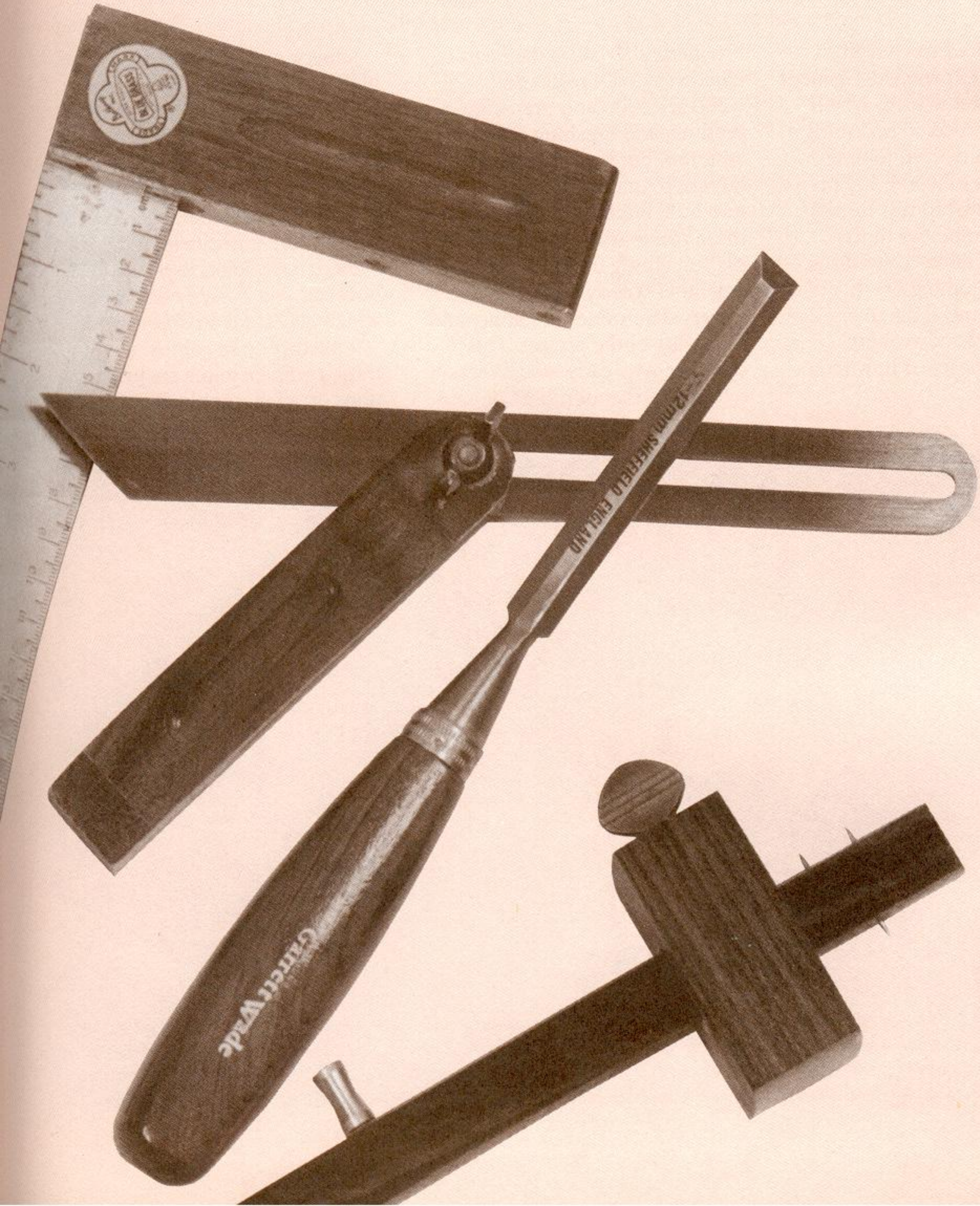

1

A JOINERY PRIMER

Think back to your first woodworking experience. Chances are that this fateful deed, which set you on the road to becoming a woodworker, involved joining two or more pieces of wood. My first act of craftsmanship was to nail several wooden blocks to my parents' coffee table. The satisfaction of solidly joining one board to another encouraged me to explore other areas of woodworking. (That very evening I learned how to cut a switch.)

Joinery, after all, is the heart of woodworking. Project design, wood selection and preparation, sanding, and finishing are important, too. But we spend most of our shop time cutting large boards into little pieces, then assembling those pieces with the hope of making something useful. More than any other woodworking skill, joinery determines the utility and durability of the project. This could be why early woodworkers referred to themselves as "joiners."

Joinery, unfortunately, is also one of the most misunderstood subjects in woodworking. It's easy to see why. Open any book on woodworking and you'll see dozens, maybe hundreds of ways to join one board to another. Each one seems more intricate than the last. With so many joints to choose from, how can you possibly determine which is best for a particular job?

It needn't be so confusing. All those complex joints are just variations on a few simple themes.

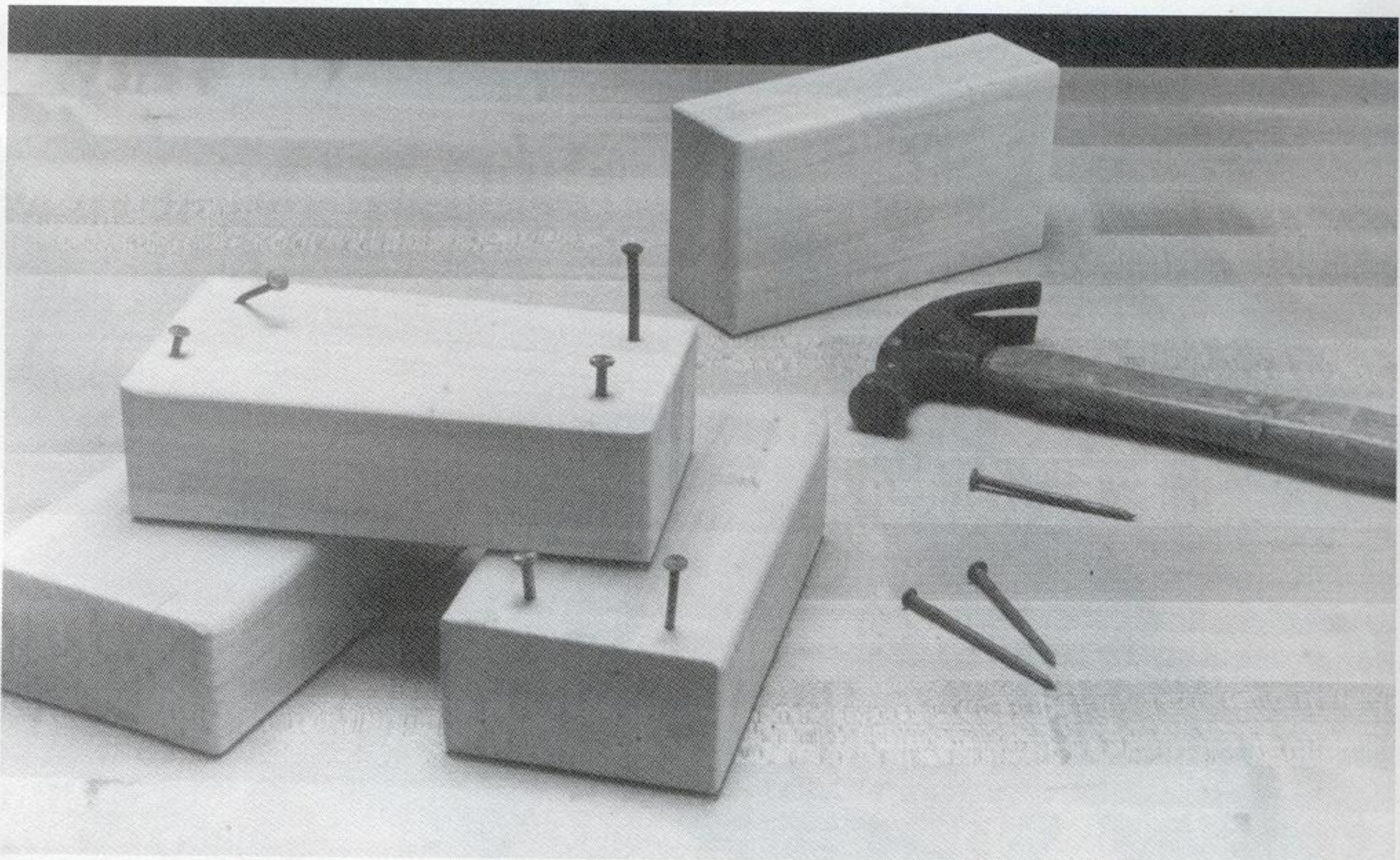

TYPES OF JOINTS

THREE BASIC OPERATIONS

Boards can be joined in three different ways:

- *Fitting* joins the mating surfaces of the parts with no gaps or openings. The boards are cut to fit one another. These cuts can be as simple as those in a butt joint or as intricate as the tails and pins of a dovetail joint.

- *Gluing* bonds two boards with a chemical adhesive, such as animal hide glue, aliphatic resin (yellow) glue, or epoxy.

- *Fastening* secures one board to another with wood or metal fasteners, such as pegs, nails, and screws.

To make most wood joints, you must combine two or more of these basic operations. For example, you might fit a simple butt joint and reinforce it with nails. Dovetail joints are typically fitted and glued. And a few joints, such as a pegged mortise and tenon, combine all three activities — fitting, gluing, and fastening. (SEE FIGURE 1-1.)

FOUR WAYS TO FIT

Of these three operations, however, fitting is the most essential. You can join wood without glue or nails, but not without fitting. Even a simple butt joint requires that you cut one board to fit flush against the surface of another. Gluing and fastening are important — and I'll refer to them from time to time — but fitting is the essence of joinery. Most of this text focuses on how to *fit* four basic types of joints (SEE FIGURE 1-2):

- *Simple joints*, such as dados and rabbets, require only a few simple cuts to assemble two parts.

- *Reinforced joints* use a secondary piece of wood, such as a dowel or spline, to strengthen the joint between two or more principal parts.

- *Mortise-and-tenon joints* have one part that is bored or recessed to hold a second part, and are mostly used to join the parts of a *frame*.

- *Interlocking joints* use multiple cuts to increase the adjoining surface area, and usually join the parts of a *box*.

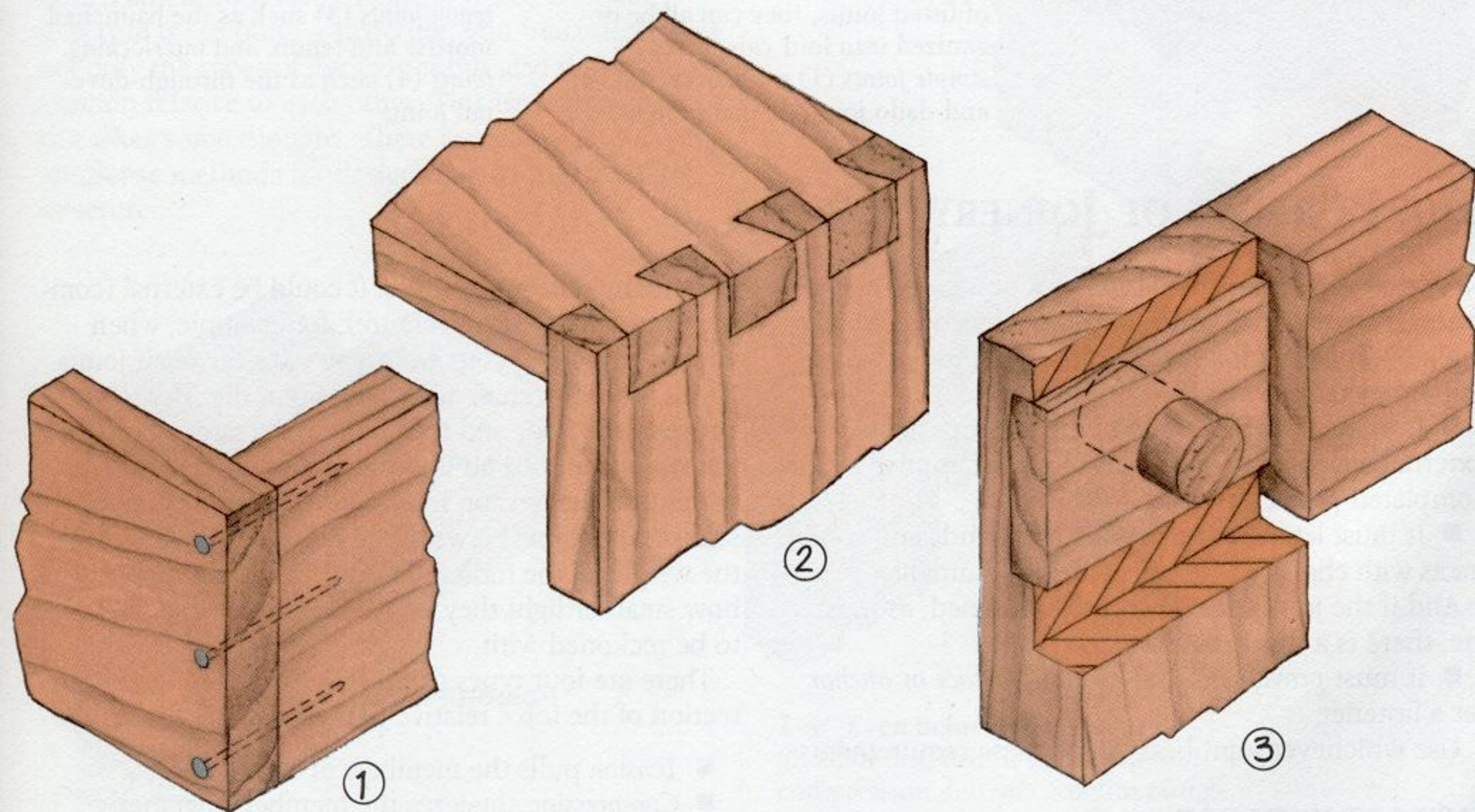

1-1 Most woodworking joints combine two joining operations — either fitting and fastening, as with the nailed butt joint (1), or fitting

and gluing, as with the dovetail joint (2). Some combine all three, such as the pegged mortise-and-tenon joint (3) — it's fitted, fastened, and glued.

Note that all of these joints require some degree of *fitting*. Just as joinery is the heart of woodworking, fitting is the heart of joinery.

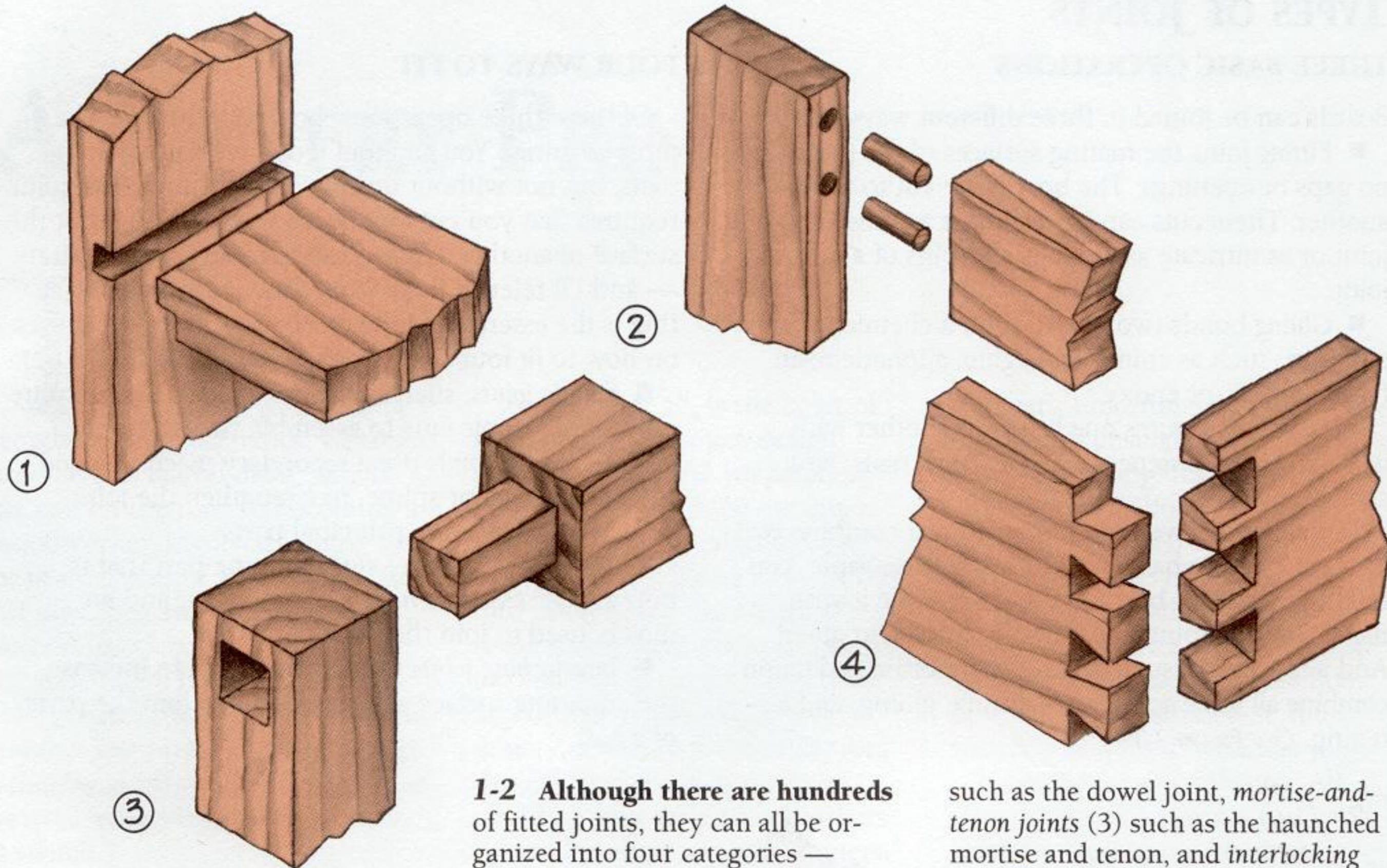

1-2 Although there are hundreds of fitted joints, they can all be organized into four categories — simple joints (1) such as the rabbet-and-dado joint, reinforced joints (2)

such as the dowel joint, *mortise-and-tenon joints* (3) such as the haunched mortise and tenon, and *interlocking joints* (4) such as the through-dovetail joint.

THE PURPOSE OF JOINERY

Now that you know the basic types of joinery, how do you choose the right joint for a particular woodworking job? Consider that every joint must fulfill two important requirements:

- It must *support the load* of the other parts and any external weights or forces that might be applied to the completed project.

- It must *let the wood move* as it expands and contracts with changes in temperature and humidity.

And if the joint is to be glued or fastened, as most are, there is a third requirement:

- It must *provide a suitable gluing surface or anchor* for a fastener.

Use whichever joint best fulfills these requirements.

SUPPORT THE LOAD

The parts of a woodworking project are elements of what engineers call a “stress system.” Each joint must withstand a certain amount of stress pushing or pulling at the members of the joint. This stress comes

from many different sources. It could be external (coming from outside the structure); for example, when you sit on a chair, your weight stresses the chair joints. If you scoot the chair across the floor, the friction between the floor and the chair legs creates stress. Or the stress could be an internal factor, inherent to the structure. The tension in a woven seat, for example, stresses the joints between the rails and the legs. Even the weight of the individual chair parts, no matter how small or light they may be, is an internal stress to be reckoned with.

There are four types of stress, categorized by the direction of the force relative to the joint (SEE FIGURE 1-3):

- *Tension* pulls the members of a joint apart.
- *Compression* squeezes the members together.
- *Shear* pushes the members in opposite directions. The lines of force are parallel, but not aligned as they are with tension and compression.
- *Racking* (or bending) rotates the members around one another.

Even before they've been glued or fastened, fitted joints resist one or more types of stress. (SEE FIGURE 1-4.) After they're assembled, they resist all types to a greater or lesser degree. When choosing a joint, try to pick one that will withstand the anticipated stress without glue or fasteners. That way, if the glue bond or the hardware fails, the joint will stay together.



FOR YOUR INFORMATION

Of the four types of stress, racking is the most destructive. A racking force bends the members of a joint like levers. A lever, as you know, will move a heavy object when you apply a relatively small force — the force is multiplied by the pivoting action of the lever. For this reason, a small amount of racking will pop a joint that might otherwise withstand large amounts of tension, compression, or shear.

For most woodworking projects, however, you must do more than pick a joint or two. You must design an entire *system* of joints — this is what a structure is. To build a structure, you must determine not only the types of joints in it but also their size and location relative to each other. This isn't difficult; it just takes some thought. There are a few simple commonsense methods for designing a strong, durable structure:

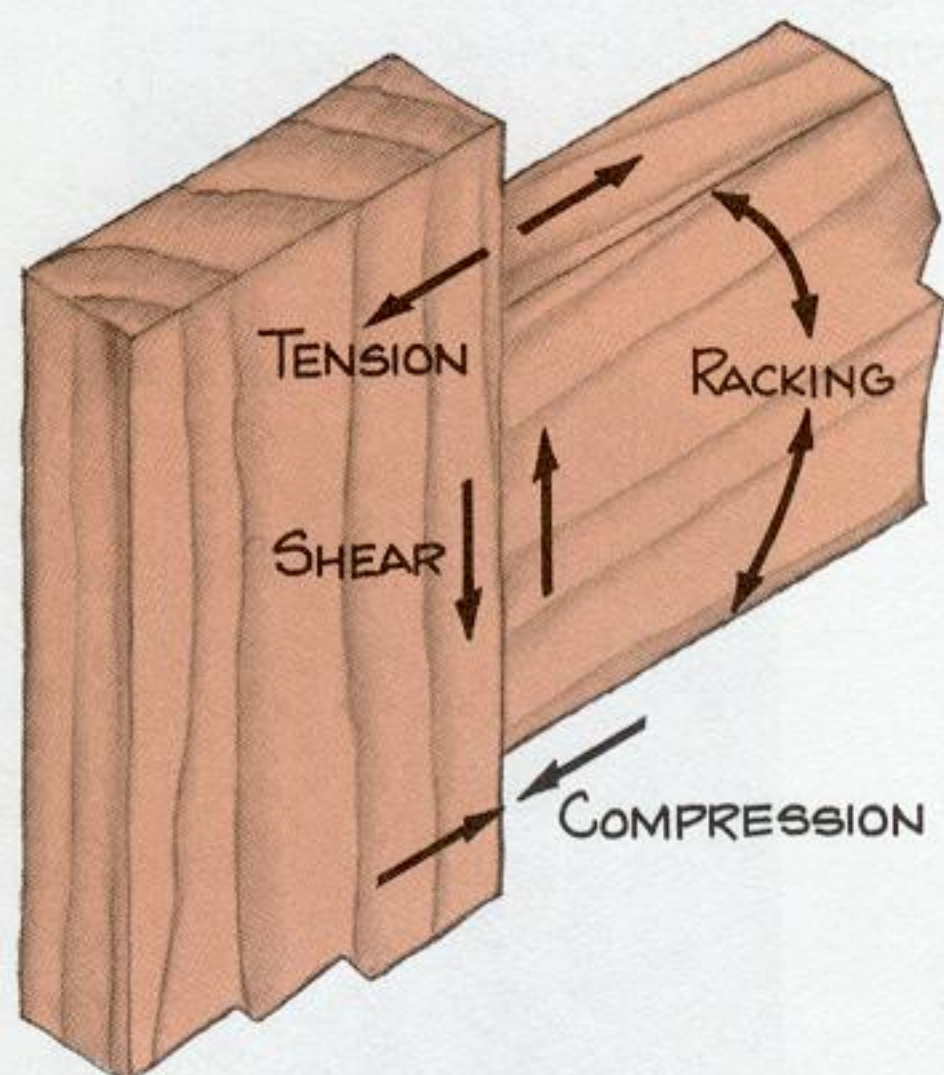

1-3 Four types of stress may tear a wood joint apart — *tension, compression, shear, and racking*. Of these, racking is the most destructive.

- Use larger joints and structural members. This distributes the load over a larger area and larger mass. (SEE FIGURE 1-5.)

- Use smaller members, but more of them. This too increases the area and mass that supports the load. (SEE FIGURE 1-6.)

- Triangulate the members. Rearrange the structural members or add new members, braces, glue joints, or fasteners to create structural triangles. When a triangle is fastened at all three corners, it's very rigid. This is why engineers triangulate bridges and roof trusses. (SEE FIGURE 1-7.)

- Orient the wood grain properly; wood is always strongest parallel to the grain. A tenon or dovetail cut across the grain will soon break.

- Increase the glue surface in a joint by making the fitted surfaces more intricate. (SEE FIGURE 1-8.)

- Increase the size or the number of fasteners.

- Use both glue *and* fasteners.

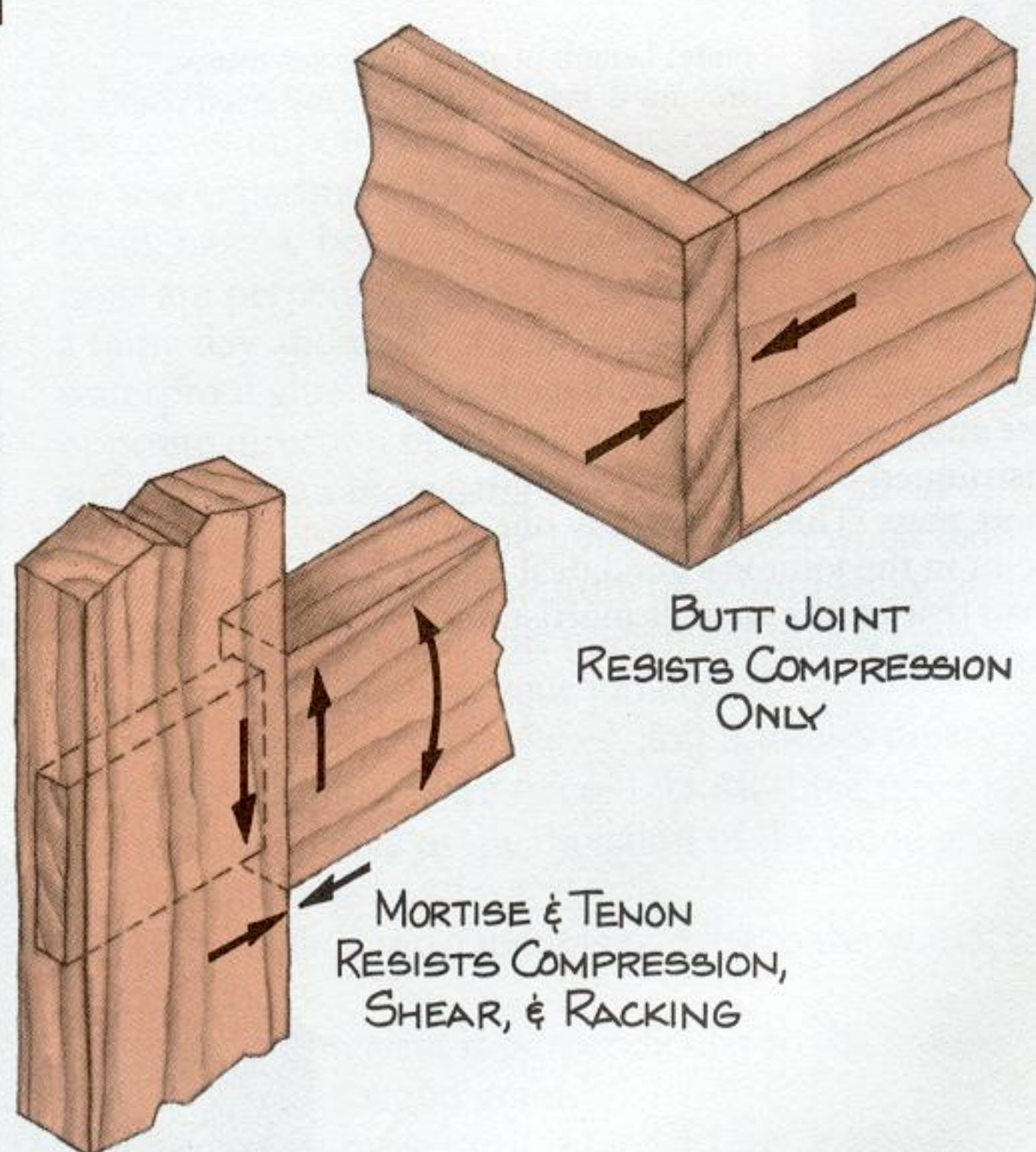

BUTT JOINT
RESISTS COMPRESSION
ONLY

MORTISE & TENON
RESISTS COMPRESSION,
SHEAR, & RACKING

1-4 Even before a butt joint is glued or fastened, it will withstand compression, but any amount of tension, shear, or racking will pull it apart. A mortise-and-tenon joint, on the other hand, will resist compression, shear, and racking. Only tension can pull it apart before it's secured.

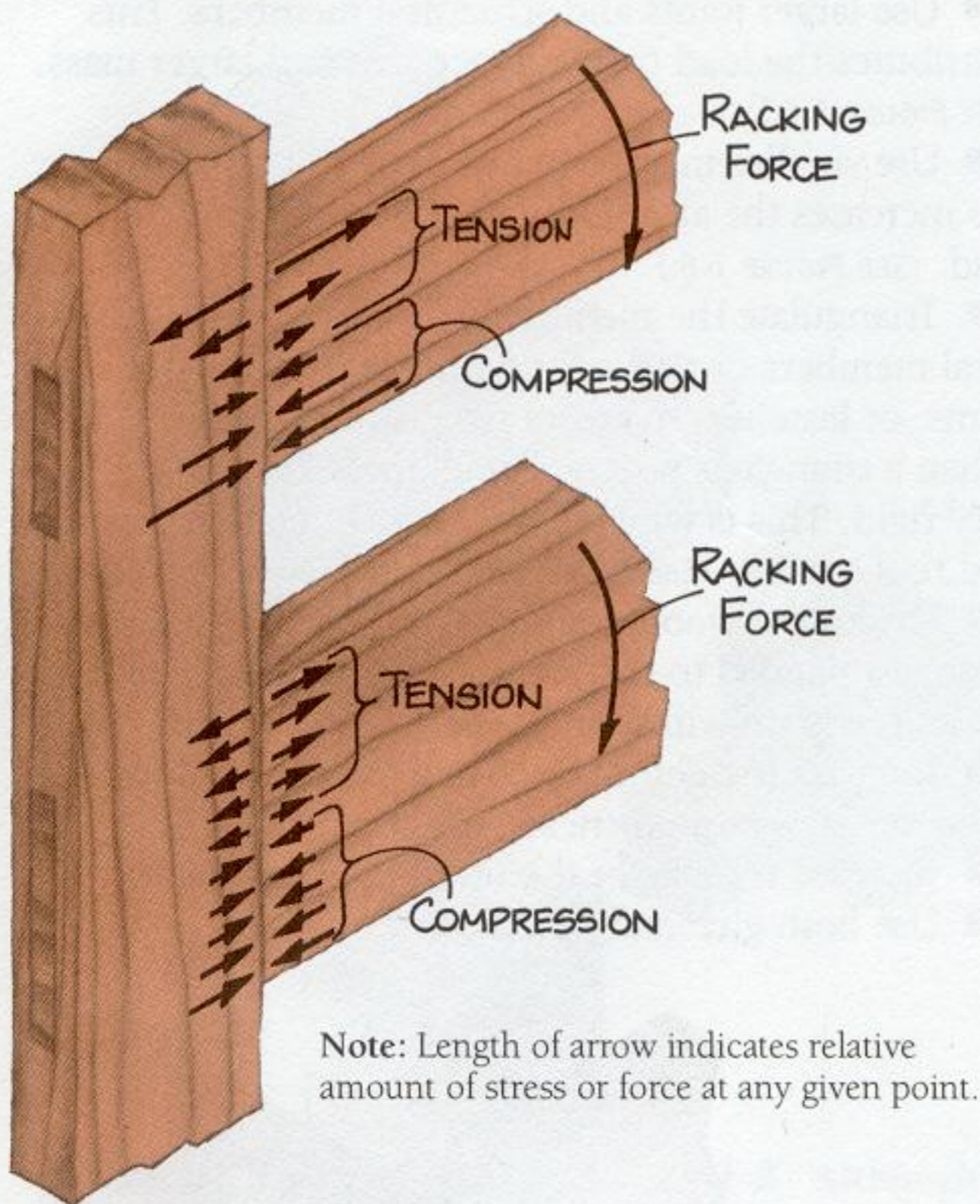

1-5 The racking force applied to both of these mortise-and-tenon joints is equal. But on the large mortise and tenon (*bottom*), the load is distributed over a larger area and more mass. The stress at any one point in the joint is a good deal less than that on the smaller mortise and tenon (*top*).



1-6 You don't have to use massive structural members or joints to support a large load. On this Shaker rocker, the load is distributed over many small, round mortise-and-tenon joints. The chair's frame and joinery appear very delicate, yet it has survived constant use for almost two centuries.

1-7 Structural triangles don't all have to look like roof trusses. On a table, the upper part of the leg and the apron form a hidden triangle that keeps the structure rigid. On a board-and-batten door, the nails form triangles that keep the door square.

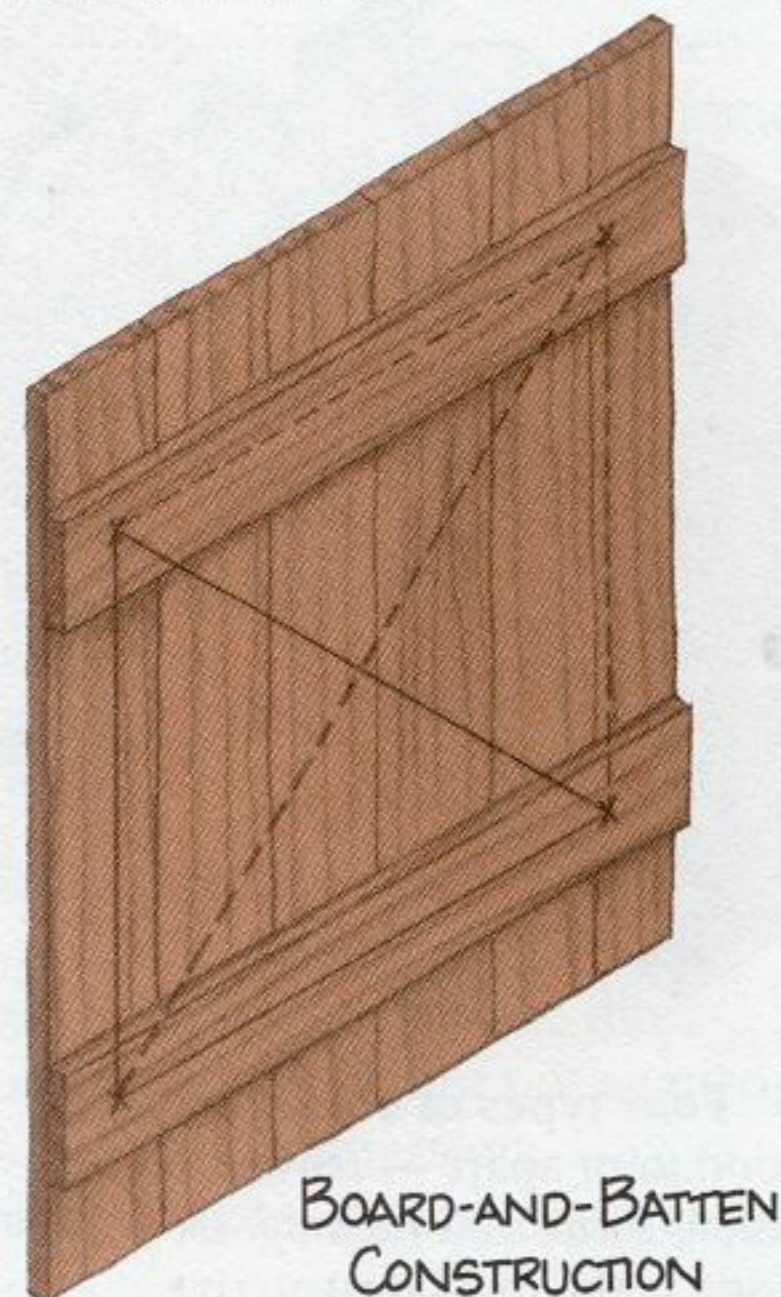
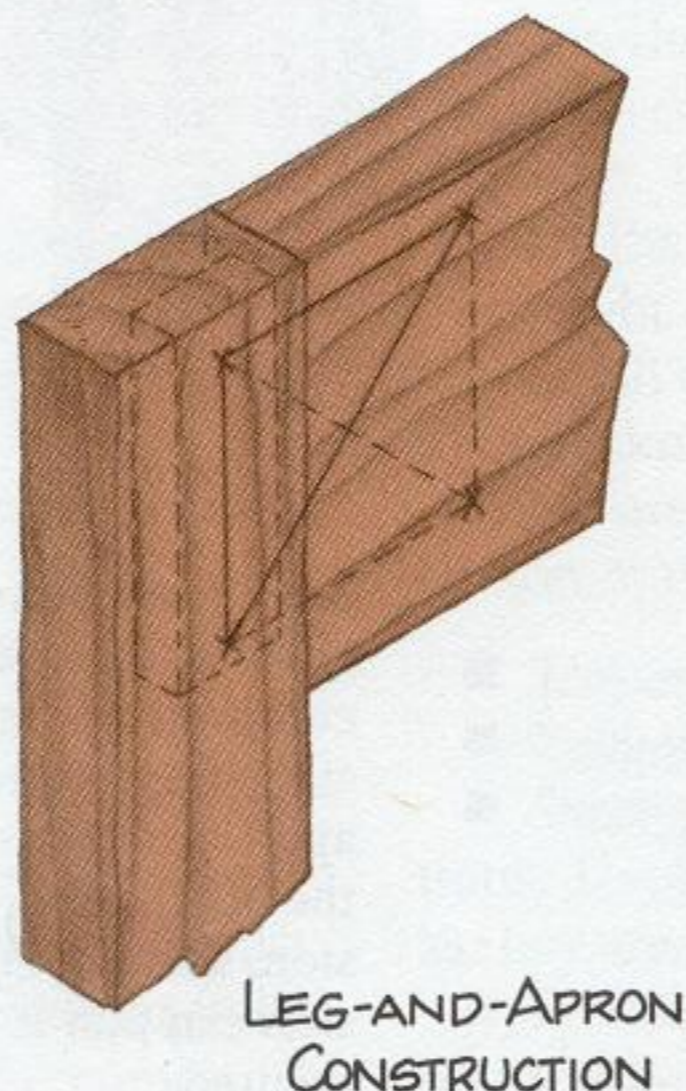

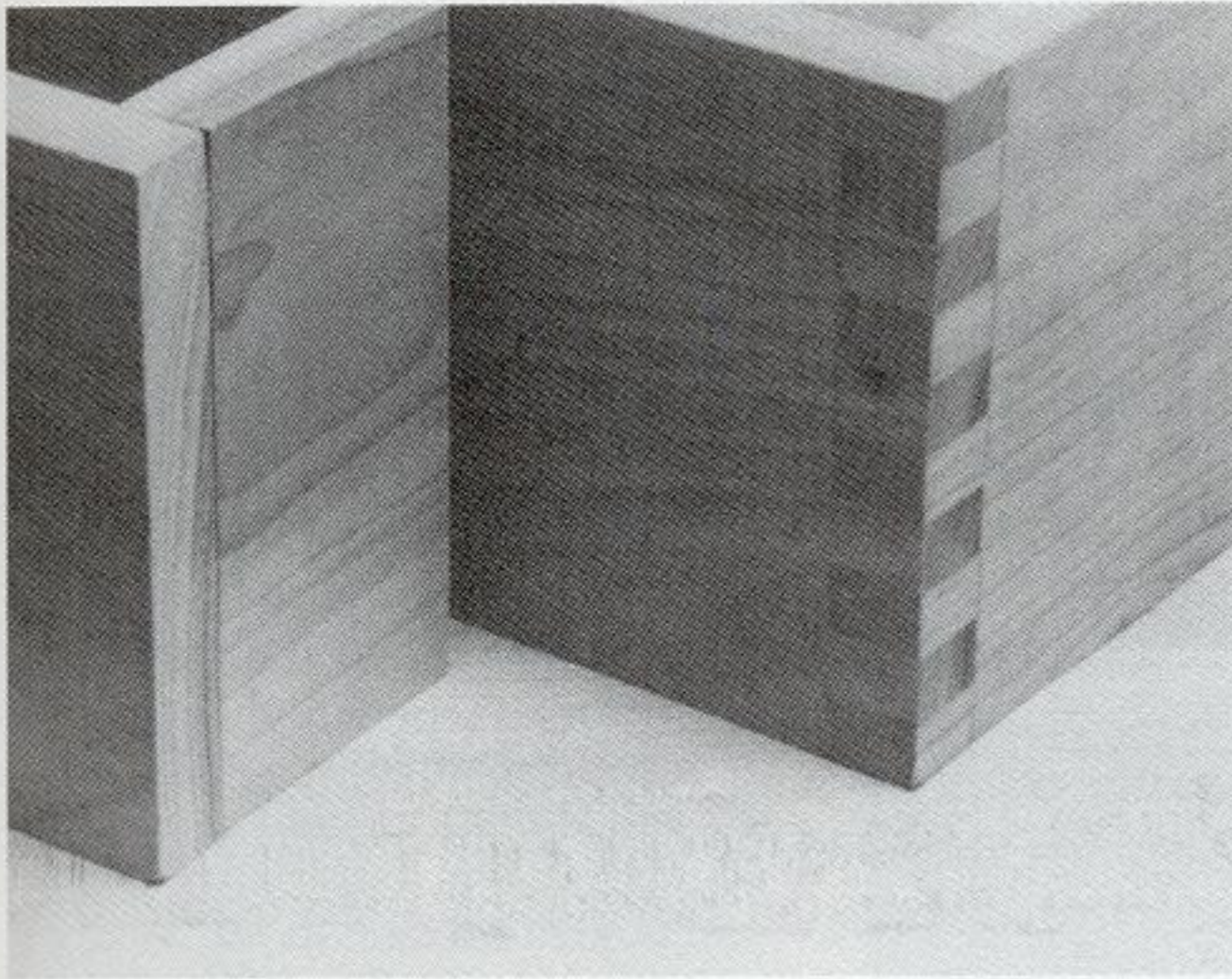

1-8 The adjoining members of both the butt joint (left) and the box joint (right) are precisely the same size. However, the fitted fingers of the box joint offer more gluing surface than the flat surfaces of the butt joint. Consequently, the box joint is much stronger.

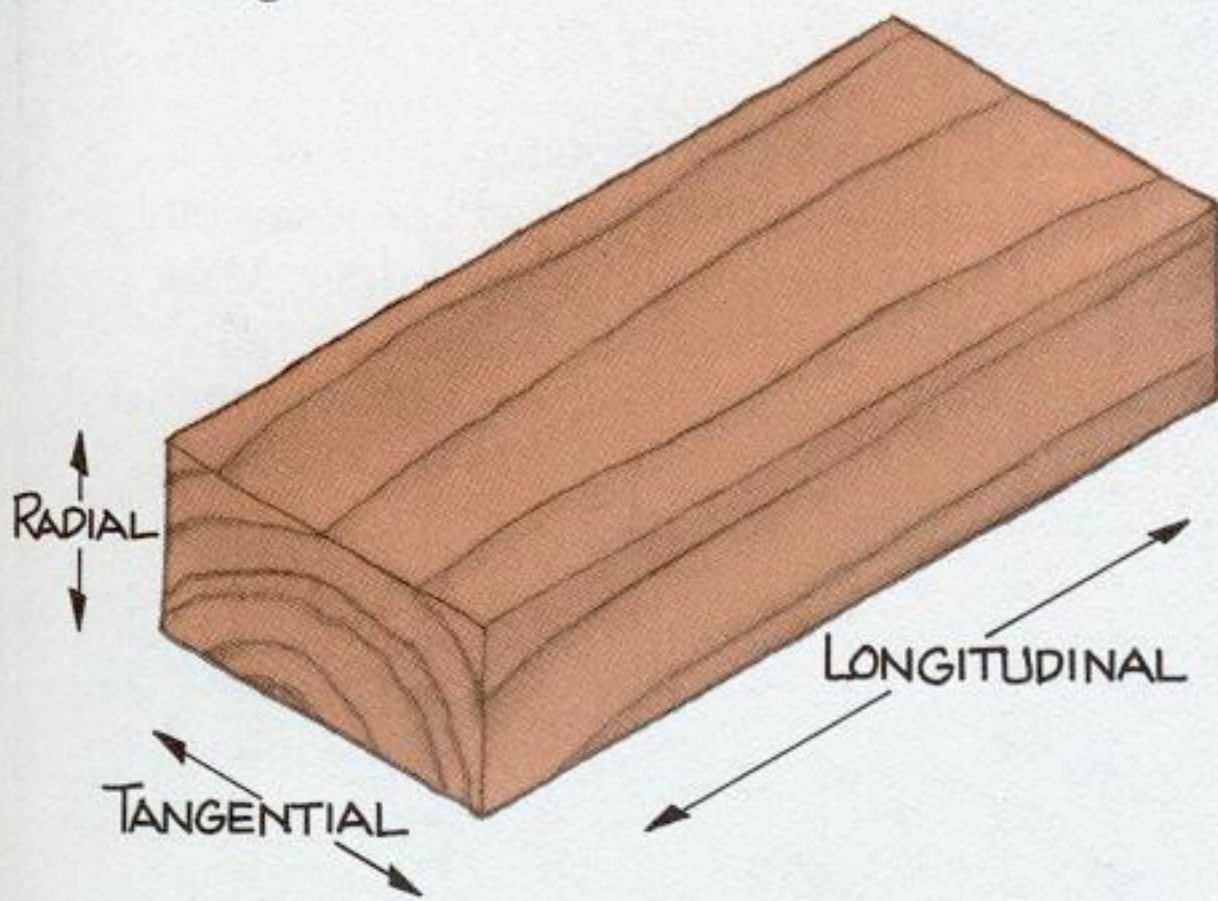

1-9 Wood moves in three different planes — *longitudinal*, or parallel to the wood grain, *radial*, or perpendicular to the annual rings, and *tangential*, or tangent to the annual rings. Wood is fairly stable longitudinally — it will only shrink or swell .1 percent of its length when originally cut. However, it's unstable radially and tangentially. Furthermore, the tangential movement in most woods is about twice the radial movement. Radial movement averages 4 percent (of the original cut dimension) and tangential movement averages 8 percent.

LET THE WOOD MOVE

Wood shrinks and swells with changes in the relative humidity (the amount of moisture in the air relative to the temperature). When the relative humidity goes up, the wood absorbs some of this moisture and swells. When the relative humidity goes down, the wood loses moisture and shrinks. Since the average relative humidity in much of the world is lower in the winter than it is in the summer, wood tends to shrink each winter and swell each summer.



FOR YOUR INFORMATION

On the average, the moisture content of wood changes 1 percent for every 5 percent change in the relative humidity.

This movement, although it may seem slight, is extremely important to woodworkers. To see why, try this experiment: Using waterproof glue, attach a small, narrow board to a wide one so the grain directions are perpendicular. Set this assembly outside on a rainy day and the boards will separate, despite the waterproof glue. As the wide board expands in the opposite direction of the narrow one, the joint is subjected to an increasing amount of shear stress. Eventually, it breaks. More joints fail from wood movement due to changes in moisture than from abuse and neglect. You must take this movement into account and accommodate it in your joinery.

Wood moves in three planes, and it moves differently in each plane. (SEE FIGURE 1-9.) All three types of motion are relative to the direction of the wood grain and annual rings:

- *Longitudinal* movement is parallel to the wood grain.
- *Radial* movement is perpendicular to the annual rings and to the wood grain.
- *Tangential* movement is tangent to the annual rings and perpendicular to the wood grain.

Wood is fairly stable longitudinally. An 8-foot-long spruce board will shrink less than $\frac{1}{16}$ inch along its entire length, from the time it's cut "green" (and about as saturated with moisture as it will ever be) to the time it's dried to 7 or 8 percent moisture content (dry enough for cabinetmaking and furnituremaking). Consequently, most woodworkers treat wood as if it were motionless along the grain.

Across the grain, it's a different story: Some woods may move up to $\frac{1}{4}$ inch for every 1 foot of width or thickness. Furthermore, there is a big difference between radial and tangential movements. Most wood species will shrink or swell about twice as much tangent to the annual rings as perpendicular to them. "Tangential/Radial Movement of Common Wood Species" on the facing page compares the movement of several species along these different planes. As the ratio of tangential movement to radial movement becomes greater, it becomes increasingly important that you properly align the tangential and radial planes of adjoining parts.

The disparity between radial and tangential movement causes yet another type of movement to consider as you choose the joinery. Depending on how a board is sawed from a tree, it may *deform* as it shrinks and swells. For example, if the annual rings run from side to side in a square table leg, the leg may become rectangular as the wood shrinks faster from side to side than from front to back. If the rings run diagonally from corner to corner, the leg may shrink to a diamond shape. A round dowel becomes an oval as the wood shrinks, and a flat board cups in

the opposite direction of the annual rings. (SEE FIGURE 1-10.) Sometimes you can use joinery to help control this deformation; other times you must simply plan for it.

This is a lot to think about. Joinery would be far simpler if wood were the relatively stable building material that many beginning woodworkers take it to be. But it's attention to details such as wood movement that marks the difference between a true craftsman and a novice. To properly join wood, not only must you plan a joint system that allows the wood to move, but you must also "read" the wood figure as you make each joint. Study each board, then orient the grain and the rings so the anticipated movement creates the least possible stress on the joint.

There are several simple joinery techniques that help reduce stress and/or control deformation caused by wood movement. Use those techniques that apply to the structure of your project.

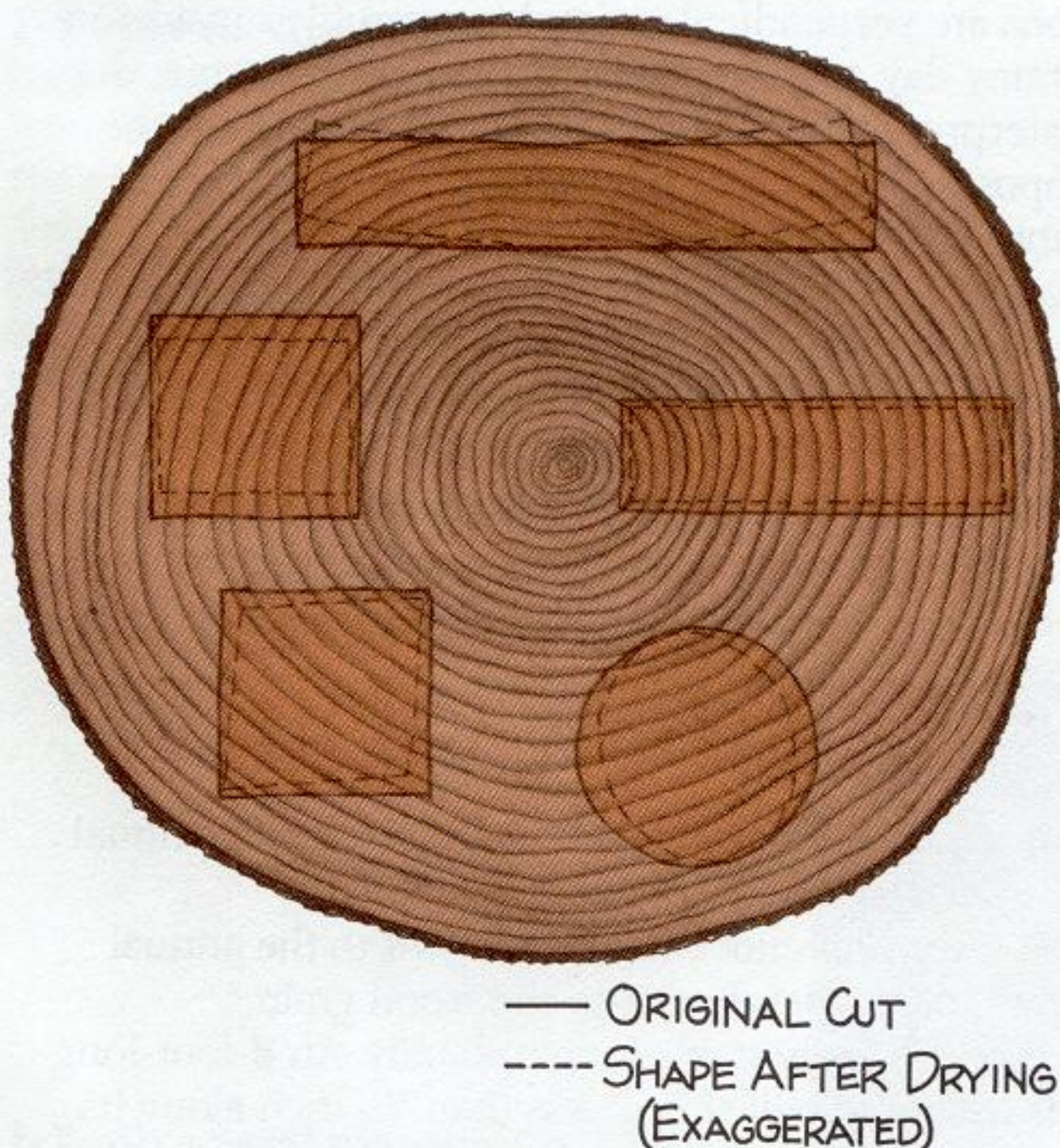

1-10 Because the radial and tangential movement of wood is uneven, boards tend to deform as they go through an annual moisture cycle. The way a board will deform depends on how it is cut from the tree.



TRY THIS TRICK

To help visualize the wood movement in a joint, sketch the boards as they will be assembled, showing the wood grain and annual rings. Mark each board with a small arrow to indicate radial movement and a large arrow to indicate tangential movement. Try to orient the wood figure so the large arrows are all parallel.

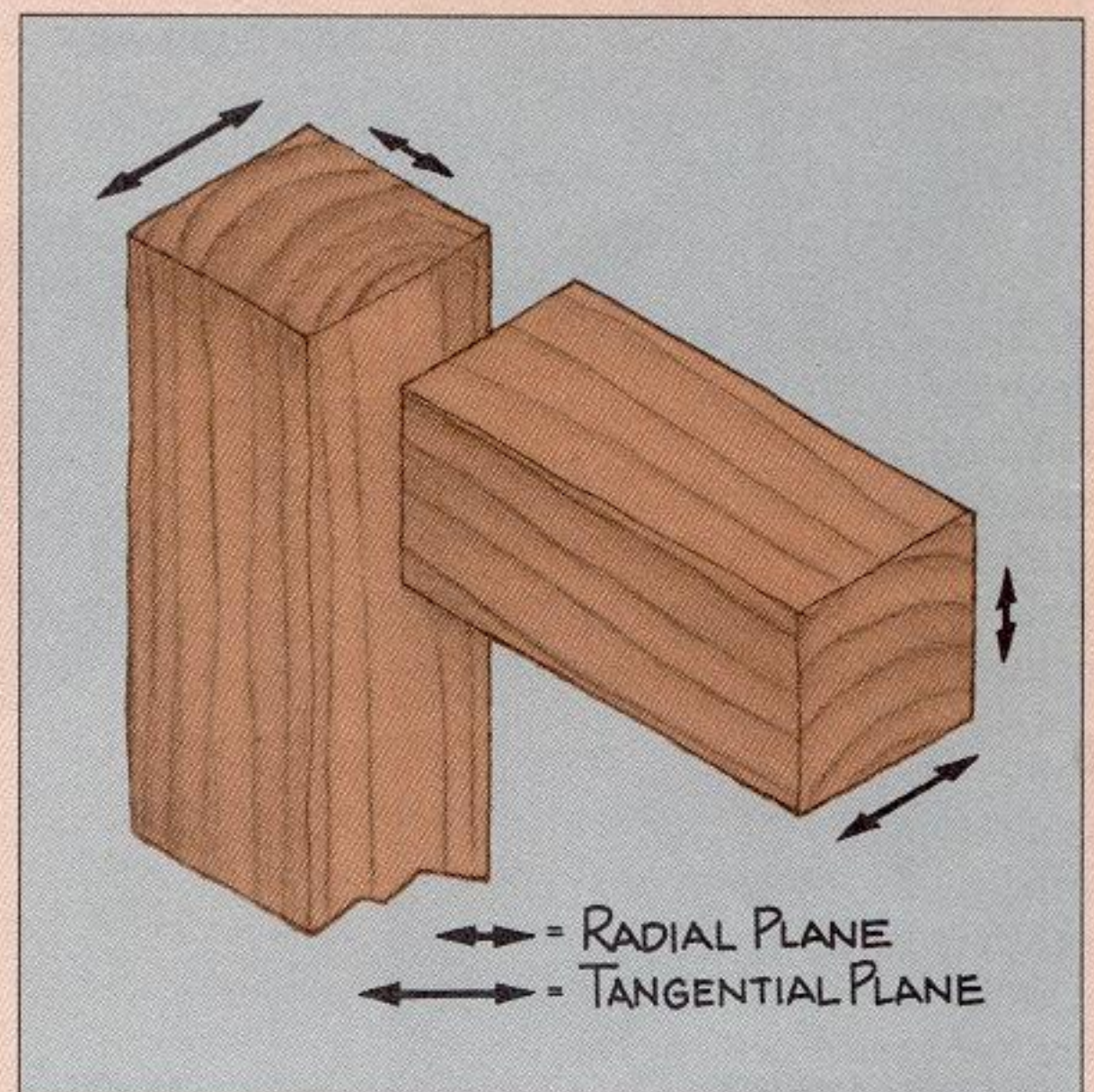

Orient the wood figure to make each part as stable as possible. Since the longitudinal plane of a board is the most stable, align this plane with the longest dimension (the length). Align the radial plane with the next longest dimension (the width), and the tangential plane with the shortest dimension (the thickness). This may not always be possible, since most boards are “plain-sawn” from logs so the *tangential*

plane is aligned with the width. If the alignment of the tangential and radial planes is critical, you may have to pay a premium price for “quarter-sawn” lumber, in which the *radial* plane is aligned with the width. Or you can rip a board into narrow strips and glue it back together with the rings properly aligned. (SEE FIGURE 1-11.)

1-11 Usually, the larger the board, the more critical it is that the longitudinal, radial, and tangential planes all be aligned for maximum stability. This is why furniture-makers glue up “butcher block” tabletops from narrow strips. Notice that each strip has been turned so the annual rings run top to bottom. The radial plane of each strip is aligned with the width of the tabletop. The tangential plane — the most unstable dimension of each strip — is aligned with the thickness, where stability matters least.

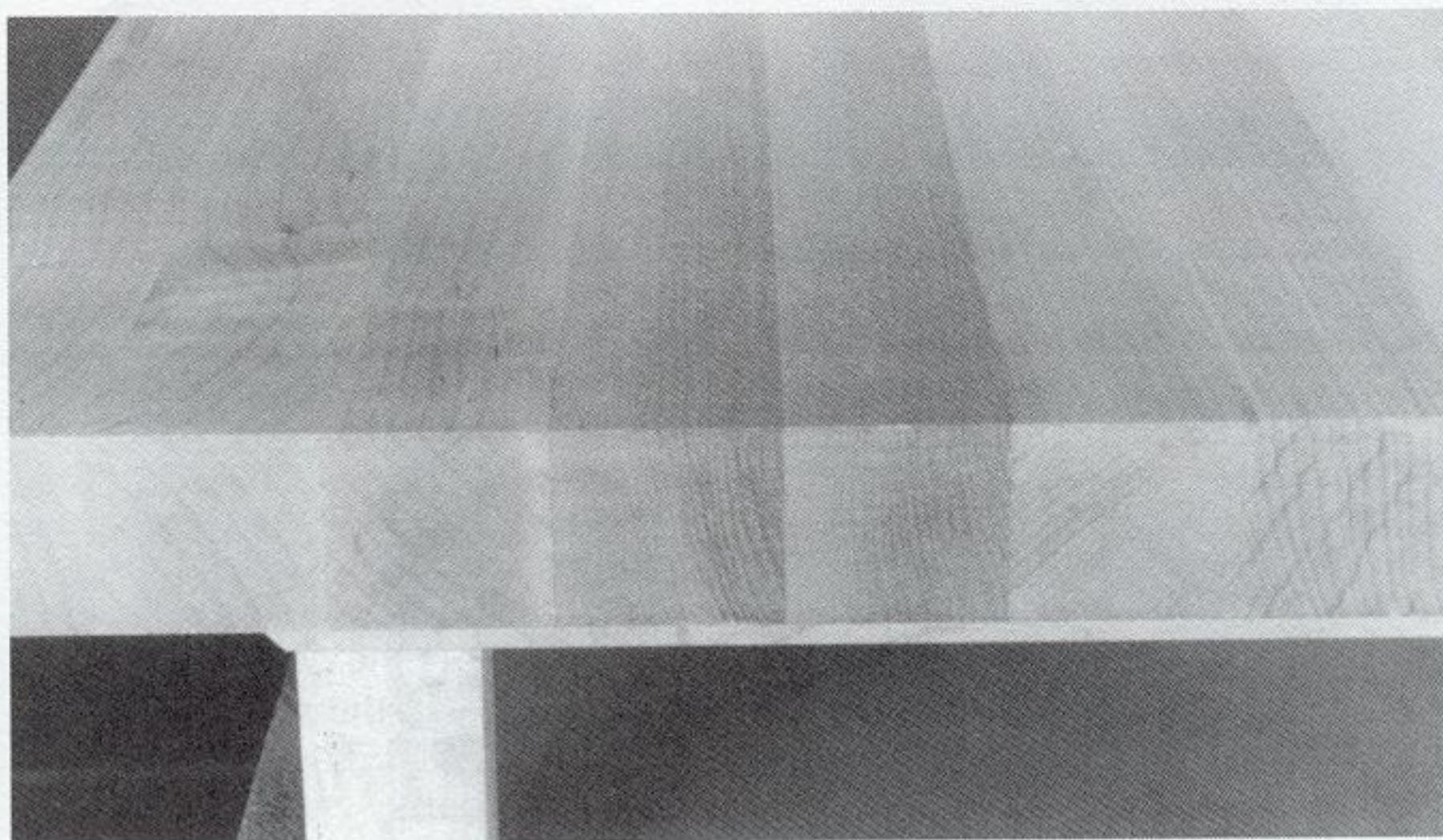

TANGENTIAL/RADIAL MOVEMENT OF COMMON WOOD SPECIES

SPECIES	TANGENTIAL*	RADIAL*	T/R RATIO
Ash, white	7.8%	4.9%	1.6 to 1
Birch, yellow	9.2%	7.2%	1.3 to 1
Cedar, aromatic	5.2%	3.3%	1.6 to 1
Cedar, western red	5.0%	2.4%	2.1 to 1
Cherry	7.1%	3.7%	1.9 to 1
Elm, American	9.5%	4.2%	2.3 to 1
Fir, Douglas	7.6%	4.1%	1.9 to 1
Mahogany	5.1%	3.7%	1.4 to 1
Maple, hard	9.9%	4.8%	2.1 to 1
Maple, soft	8.2%	4.0%	2.1 to 1
Oak, red	8.9%	4.2%	2.1 to 1
Oak, white	10.5%	5.6%	1.9 to 1
Pine, white	6.1%	2.1%	2.9 to 1
Pine, yellow	6.2%	3.9%	1.6 to 1
Poplar, yellow	8.2%	4.6%	1.8 to 1
Redwood	4.9%	2.2%	2.2 to 1
Spruce, Sitka	7.5%	4.3%	1.7 to 1
Teak	4.0%	2.2%	1.8 to 1
Walnut	7.8%	5.5%	1.4 to 1

*Percentage of shrinkage from when wood is first cut (green) to after it is kiln dried.

Orient the wood figure so the parts move in unison. Whenever possible, join the boards so the wood swells and shrinks in the same direction. When the wood grain must cross at right angles, align the tangential planes. (SEE FIGURES 1-12 AND 1-13.)

Cut large boards into smaller parts. When you must glue or otherwise fasten two boards with opposing wood grain, make sure they are as narrow as possible without compromising the strength of the structure. (SEE FIGURES 1-14 AND 1-15.)

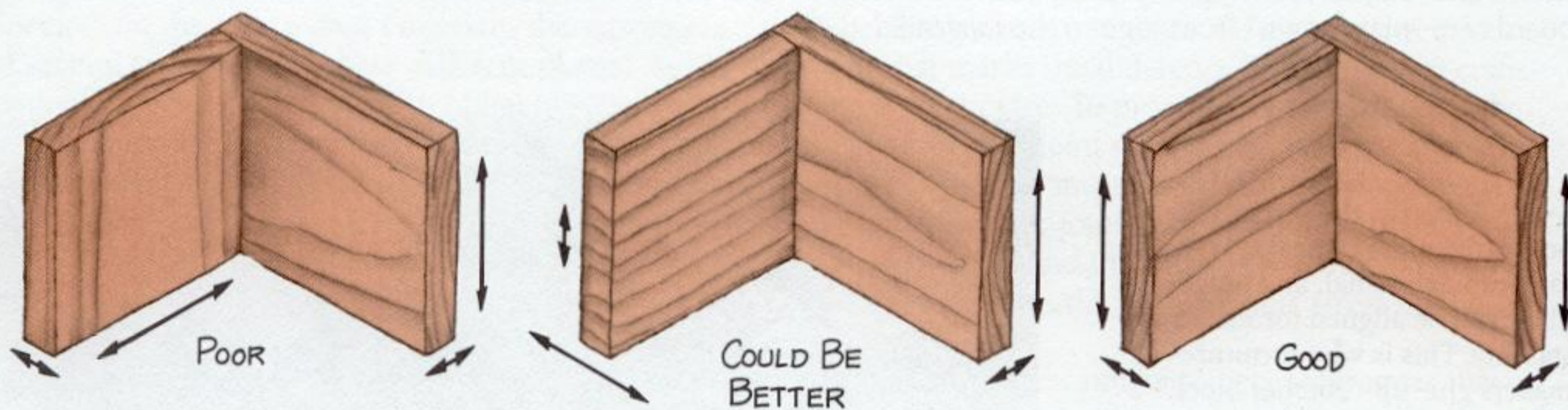

1-12 On the corner butt joint shown at the left, both the wood grain and the annual rings are opposed to one another. The joint will soon fail. On the middle joint, the wood grain is aligned, but the annual rings are not — the tangential

planes are perpendicular to one another. This joint will fail too, though not as quickly as the first. On the joint at the right, both the wood grain and the annual rings are properly aligned. This joint will last for a long time.

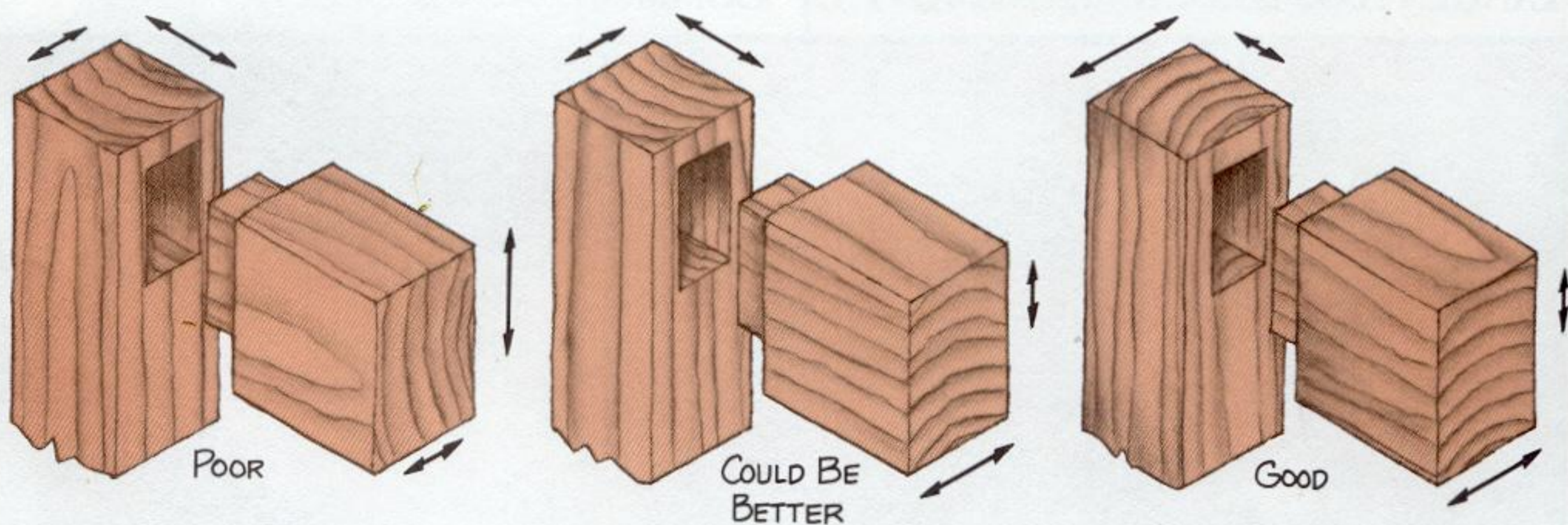

1-13 The wood grain on all three of these mortise-and-tenon joints is properly aligned. But on the joint at the left, the tangential planes are directly opposed on the broadest possible surface — where the cheeks of the tenon meet the sides of the mortise. This greatly diminishes the useful life of the joint. On the joint in the middle, the planes are in some-

what better alignment. The tenon moves radially at right angles to the tangential movement of the mortise. But the joint at the right shows the best possible arrangement — the tenon moves radially at right angles to the radial movement of the mortise, and the tangential planes are aligned.

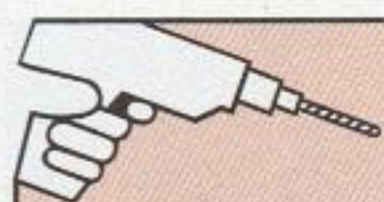

FOR BEST RESULTS

As a rule of thumb, most craftsmen limit the width of lap joints and mortise-and-tenon joints (where the wood grains of the members must be glued perpendicular to one another) to 3 inches when the *tangential* planes can be aligned, and less if they can't be.

Use “floating” joints to let the wood move. When you must join a large board to a structure and cannot cut it into smaller pieces, do *not* glue it in place. Instead, let it float in a groove or dado, free to expand and contract. (SEE FIGURE 1-16.) You can also make floating joints with screws and bolts. Cut a slot for the shank of the screw or bolt, allowing the wood to expand and contract around it. (SEE FIGURE 1-17.)

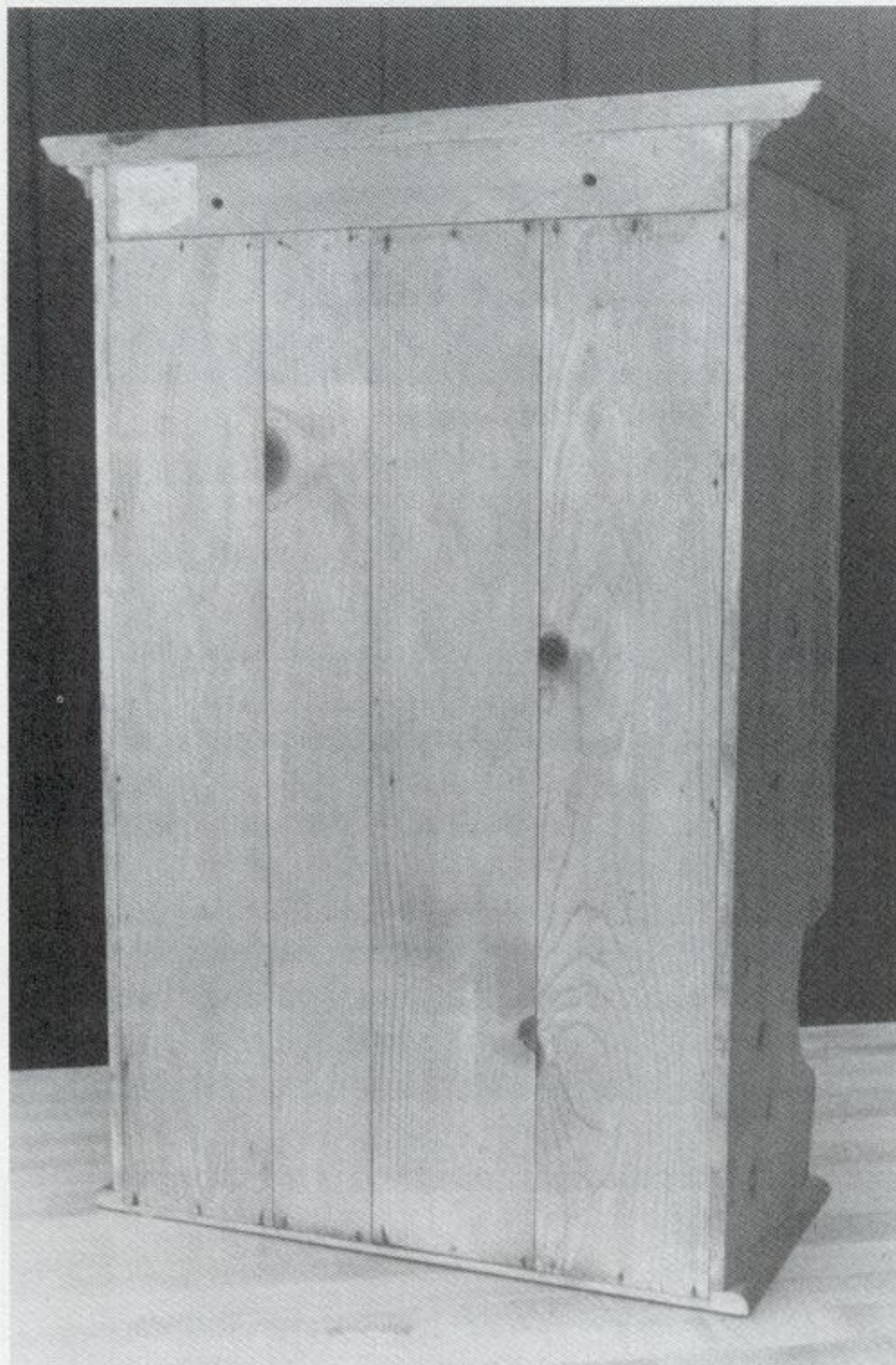

1-14 This antique spice cabinet was built in the late nineteenth century, when boards up to 24 inches wide were commonly available. However, the craftsman who built it chose to make the back from narrow boards, since he had to attach them at right angles to the shelves. This has prevented the back from buckling as it expanded and contracted for almost a century.

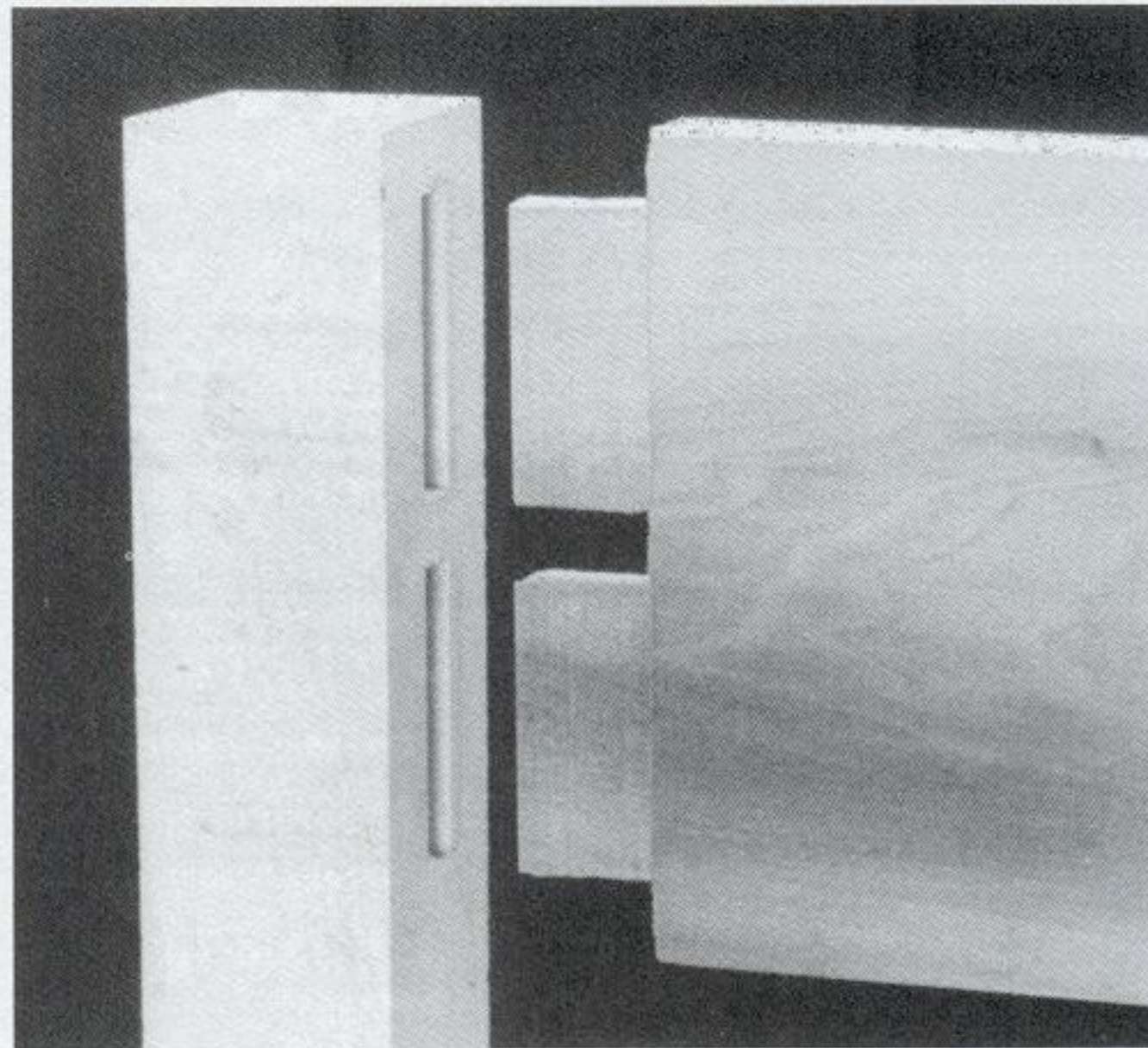

1-15 This apron will be joined to a table leg with a mortise-and-tenon joint. Like all such joints, this presents a dilemma — the mortise grain is perpendicular to the tenon grain, so the two parts move in different planes, stressing the joint. The wider the mortise and tenon, the more the parts move and the more critical this problem becomes. To alleviate some of the stress that a single wide joint might generate, the tenon on the end of this apron has been “split” into two narrower ones, each less than 3 inches wide. Instead of one wide tenon expanding and contracting in a single large mortise, there are two smaller tenons, each moving only half as much in its own mortise — and only generating half the stress. And because the gluing surface has not been greatly diminished, this split mortise-and-tenon joint is still very strong.

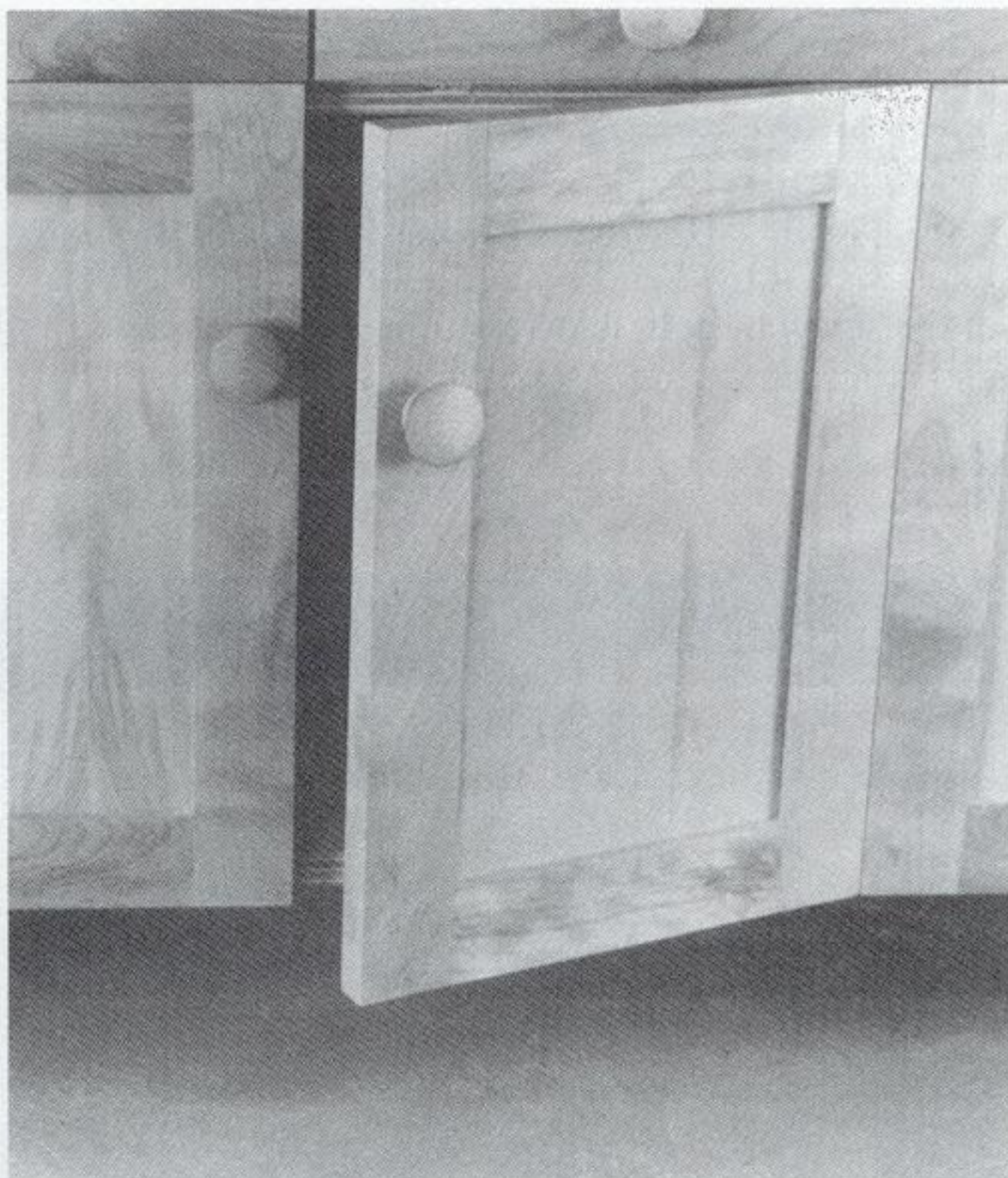

1-16 Traditional frame-and-panel construction, such as these cabinet doors, employs floating joints. The panels expand and contract in grooves cut in the inside edges of the rails and stiles.

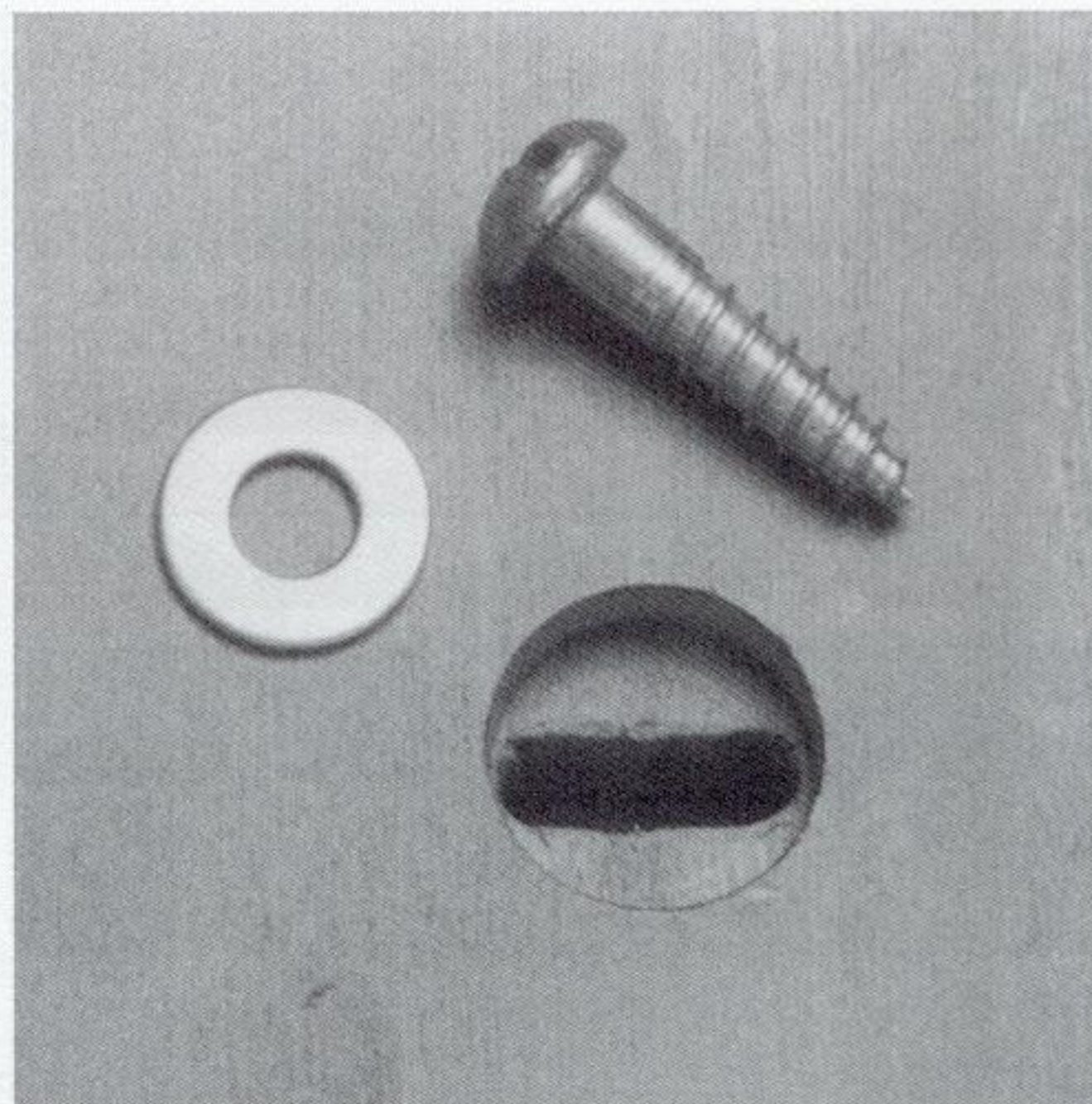

1-17 The shank of this round-head screw rests in a slot, allowing the wide board to expand and contract around it. When making floating joints for screws and bolts, cut the slot with the long direction parallel to the direction of the wood movement. Drive the screw snug in the slot, but not so tight that it restricts movement.



TRY THIS TRICK

Use small nails for floating joints when applying a small molding, as many old-time woodworkers did. The grain direction of a molding is often perpendicular to that of the board to which it's applied. If you secure the molding with brads, these tiny nails will bend slightly as the wooden parts expand and contract.

Avoid wood that may deform and stress the joint. As mentioned previously, wood not only moves, but also may change shape. Study the wood figure to anticipate how a board might deform. If this deformation will create stress in the joinery, use another board. (SEE FIGURE 1-18.)

If possible, control the deformation. Wood will expand and contract no matter what you do. If you restrict the movement, you will make matters worse. Wood will deform, too, and though this can't be

stopped, it can often be controlled. For example, a well-placed batten, brace, or screw can control cupping. (SEE FIGURE 1-19.) Sometimes, you don't need anything at all — just align the wood figure properly in the joint to restrict the deformation. (SEE FIGURE 1-20.)



FOR BEST RESULTS

After designing a joint system that allows the wood to expand and contract and carefully aligning the wood figure in each joint, there is one more thing you must do to relieve the stress due to wood movement — apply a finish. A good finish slows the release and absorption of moisture, and prevents the wood from shrinking or swelling too quickly. This, in turn, protects the wood from radical changes in relative humidity that often occur several times a week — sometimes several times a day! The wood movement is slower and gentler, and the joinery lasts longer.

1-18 Because the annual rings run diagonally through the leg on the left, the wood will expand or contract to a diamond shape. This will pull the aprons out of alignment so they are no longer square to one another. If the aprons were attached at the other end, all the joints in the leg-and-apron assembly would be stressed. Not so with the leg on the right. Because the rings run side to side, the wood will expand or contract to form a rectangle. Although the wood does deform, the aprons remain properly aligned.

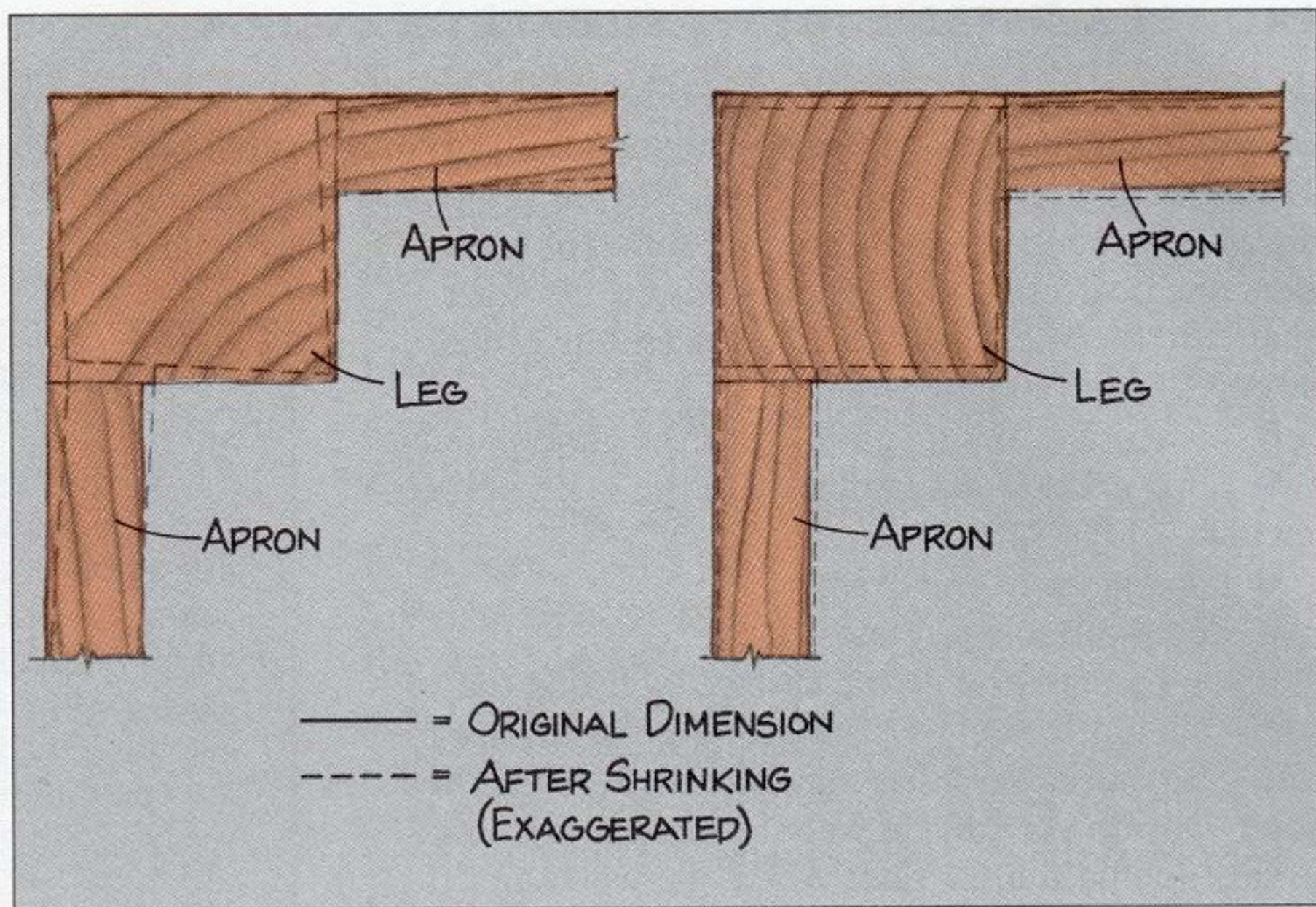

1-19 If you glue up a wide tabletop (not a butcher block) from narrower boards, turn the annual rings to curve up. If the board cups, the top will tend to rise in the middle. You can control this tendency by fastening the tabletop to the apron near the middle of the table. This leaves the sides free to expand and contract.

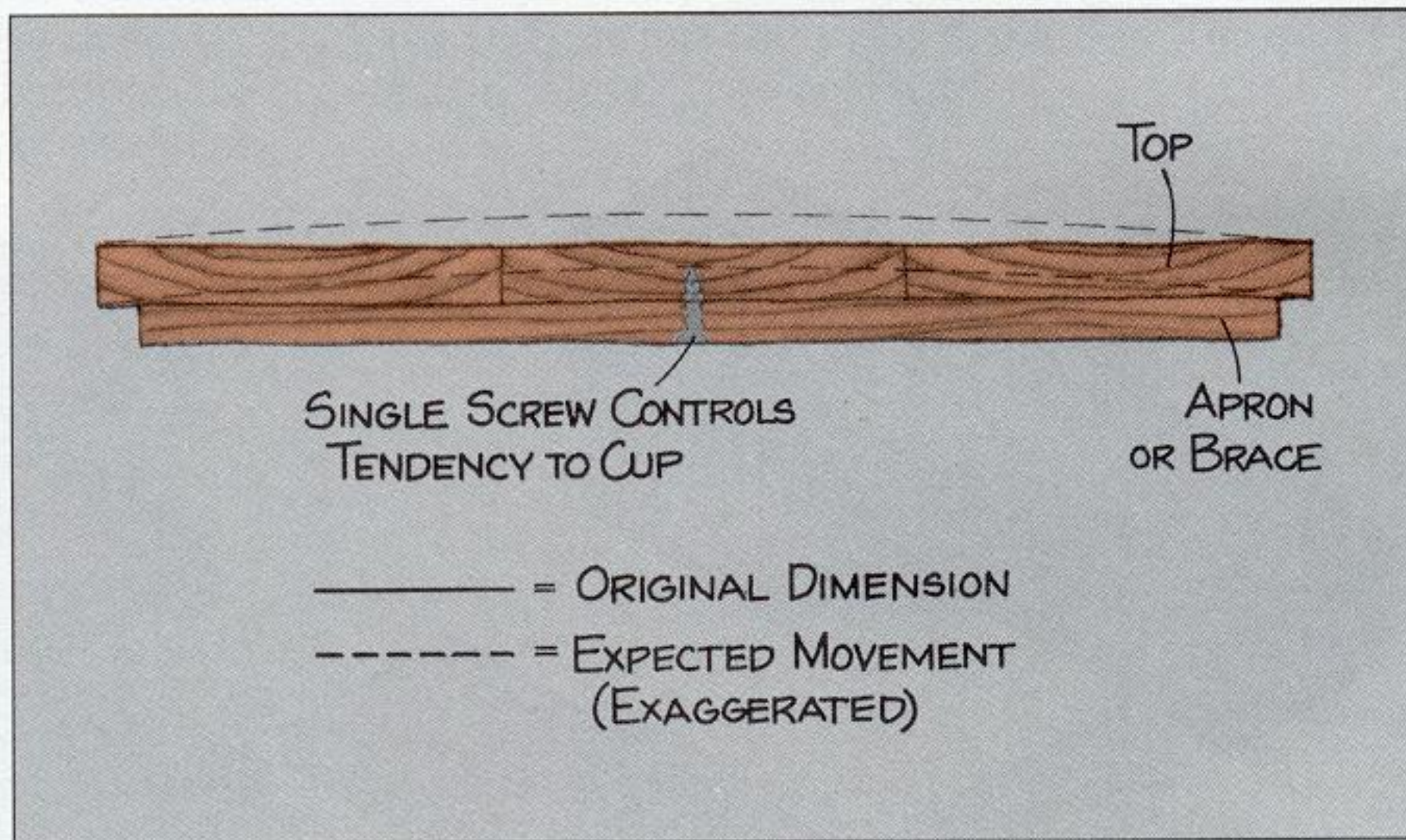

1-20 When assembling a box or drawer, turn the boards so the annual rings curve out, as shown on the right. The boards' natural tendency to cup will keep the corner joints tight at the edges. If the annual rings curve in, as they do on the left, the joints may pull apart at the edges.

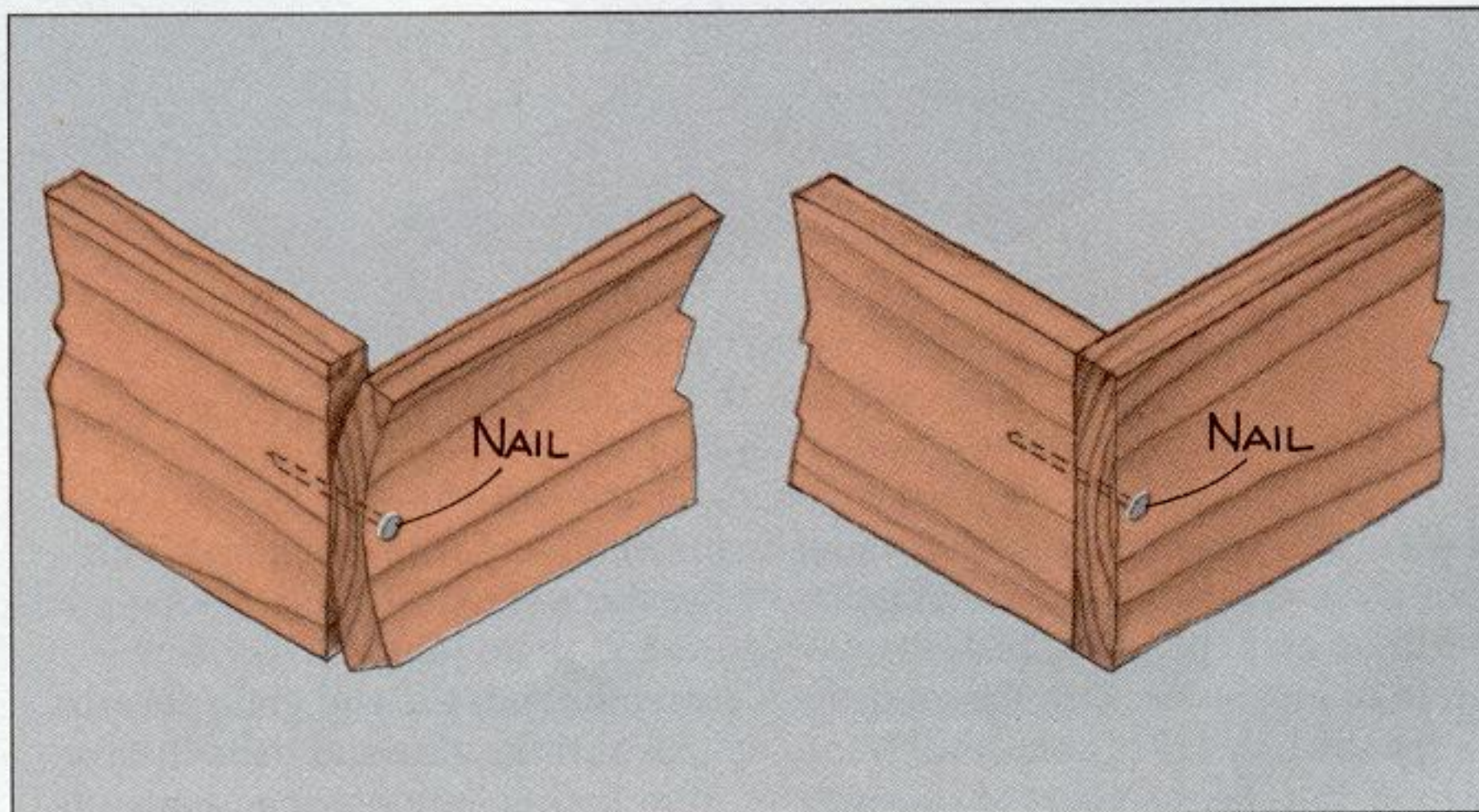

PROVIDE A SUITABLE GLUING SURFACE OR ANCHOR

As mentioned previously, the most obvious thing you can do to increase the strength of a glue joint is to increase the gluing surface. However, this isn't always as simple as it sounds. There are four different ways to glue one board to another, and some are stronger than others. (SEE FIGURE 1-21.) In descending order of strength, you can glue wood:

- Long grain to long grain, with the grain parallel
- Long grain to long grain, with the grain perpendicular

- Long grain to end grain

- End grain to end grain

If you increase the gluing surface by fitting the joint differently, don't sacrifice long-grain surface for end-grain surface — that may actually weaken the joint. Nor do you always want to increase the long-grain-to-long-grain surface where the wood grains are perpendicular. If these surfaces become too broad,

the wood movement might pop the joint. Consider other ways to expand the surface — make several small joints, or reinforce the glue bond with dowels or splines.



TRY THIS TRICK

To increase the strength of end-grain glue joints, paint the end grain with a thin coat of glue and wait about half an hour. Apply another coat of glue — this time, apply it as thick as you would normally — and clamp the parts together. The first thin coat prevents the end grain from absorbing the second coat, resulting in an even and continuous glue bond. However, don't rely on end-grain glue joints alone when strength is important.

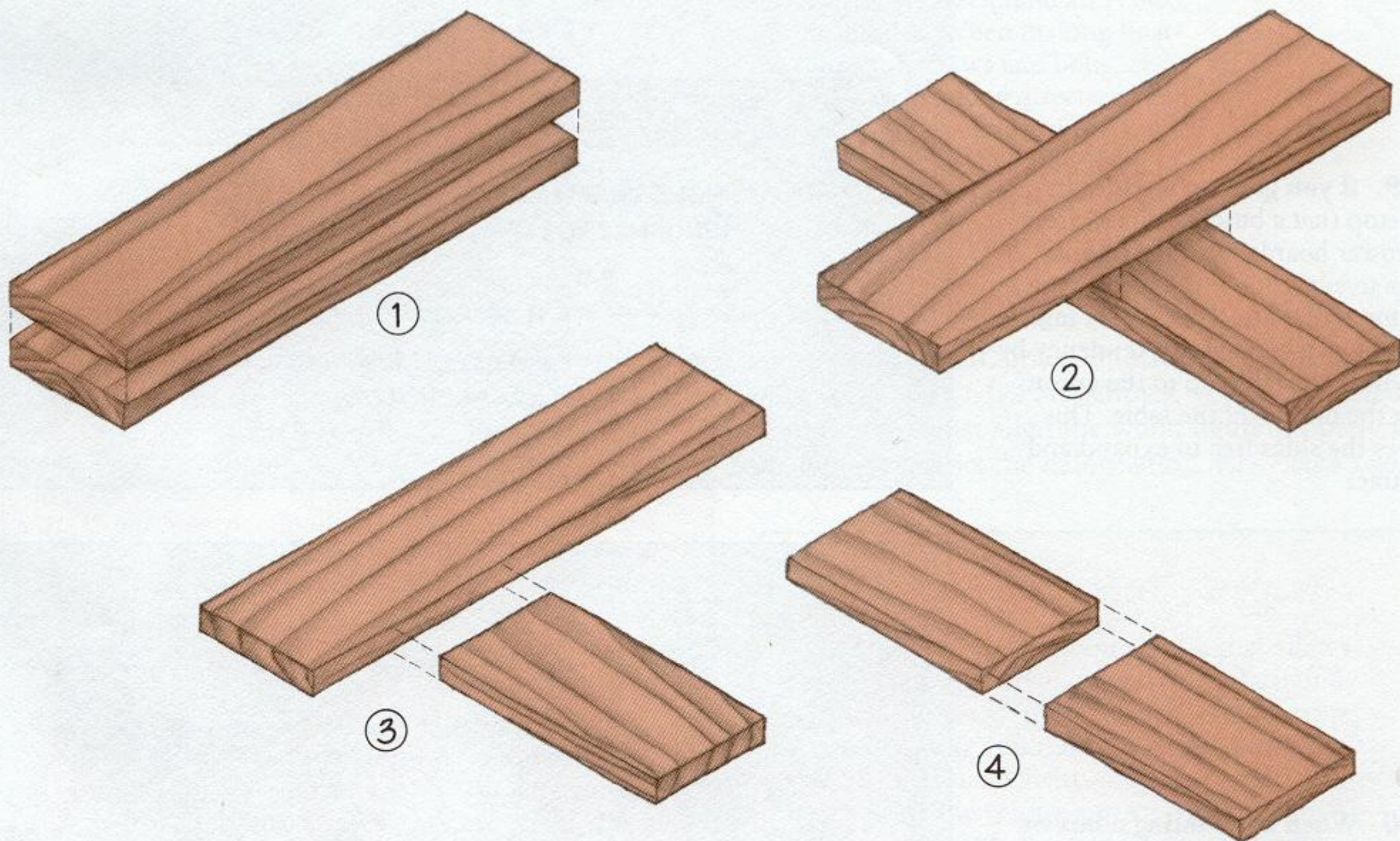

1-21 The strongest glue joint you can make is long grain to long grain with the grain parallel (1). Long grain to long grain with the grain perpendicular (2) is almost as strong, but the members of the joint

move in opposite directions. This weakens the glue bond. A long-grain-to-end-grain joint (3) has some strength, but the end grain absorbs much of the glue and the adhesive film isn't continuous; consequently,

the bond is weak. In an end-grain-to-end-grain joint (4), this problem is aggravated. Since both boards absorb the glue, the bond is even weaker.

You might also consider whether you need to increase the gluing surface at all. Providing a *suitable* gluing surface does not necessarily mean a large gluing surface. You can build strong, durable projects without oversize, intricate joints. (SEE FIGURE 1-22.) There are several other important things you can do to ensure a good glue joint:

- *Make the glue surfaces as smooth as possible.* A thin, even, continuous film of glue is essential for a strong joint. Rough surfaces make the film uneven and create voids.

- *Fit the surfaces properly.* The surfaces must fit together without any gaps. Gaps create an uneven glue film and weaken the bond. At the same time, the fit must not be too tight. A tight fit will squeeze the glue from between the boards, leaving a weak, “starved” joint.

- *Clean the surfaces.* Give the glue surfaces a light sanding with very fine sandpaper before applying the glue. This removes any foreign materials. It also helps the glue to soak in and form what chemists call an “interface” — an integral bond between the adhesive and the wood. As you sand, be careful not to round-over adjoining surfaces.

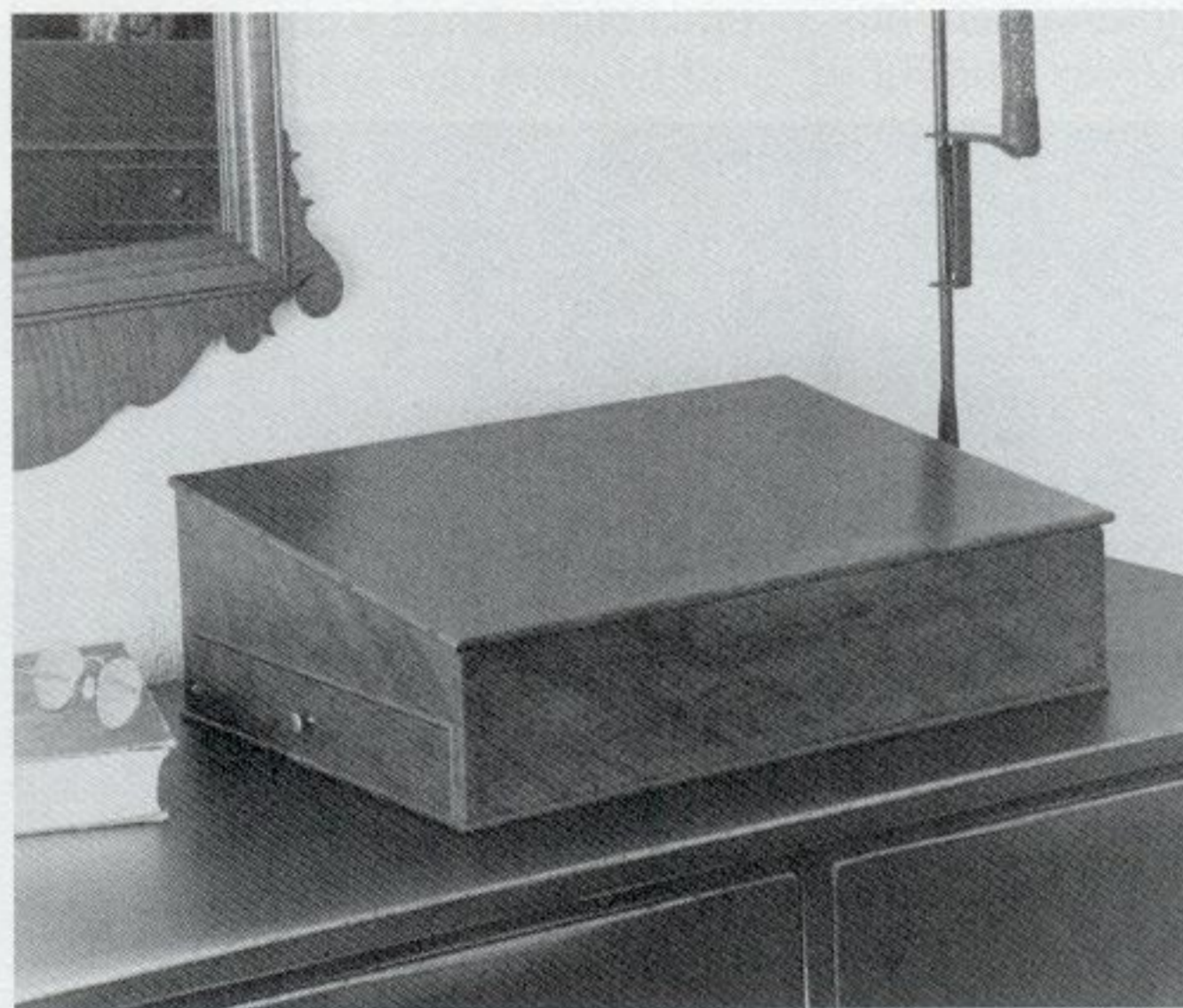

1-22 You don't need beefy, intricate joinery to make strong glue joints. This reproduction of a Shaker lap desk is made from thin stock (many parts are only $\frac{3}{32}$ inch thick) so it is as light as possible. With the exception of the dovetail joints at the corners, the joinery consists of simple butts, rabbets, and grooves. But the assembled desk is sound and solid.

The considerations are similar if you're making a fastened joint. The first thing that comes to mind when you must provide a suitable anchor for a nail or screw is to beef up the wood around it. But this isn't the only thing you can do to strengthen a fastened joint. As with a glue joint, you must consider the orientation of the wood grain. Nails and screws hold better when you drive them *through* the long grain. They may pull out or even split the wood if you drive them into the end grain. You can also:

- Use more, smaller fasteners instead of a few large ones.

- Drive fasteners at angles to one another, locking the parts together. (SEE FIGURE 1-23.)

- Use square-shanked nails or ring-shanked nails instead of ordinary nails with round, smooth shanks. The large surface area of square-shanks and the protrusions on ring-shanks help to hold the nail in the wood.

- If you must drive screws or nails into end grain, use fasteners that are as long as practical. The extra length helps them to hold tight.

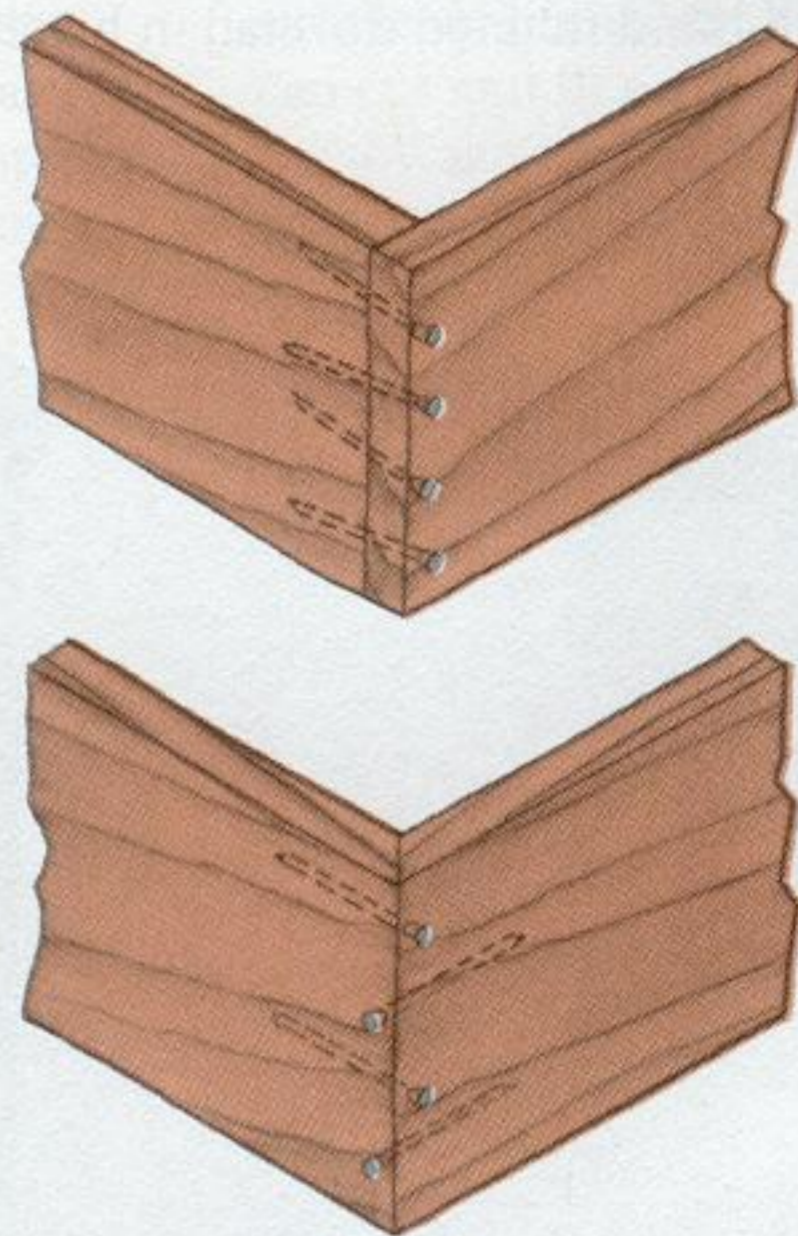

1-23 Here are two ways you might lock boards together with nails. In the butt joint (*top*), the nails are driven at slight angles, alternating right and left with each nail. In the miter joint (*bottom*), the nails are driven at right angles to one another. In both cases, the opposing angles of the nails make the joint difficult to pull apart.

THE VALUE OF SIMPLICITY

MAKING YOUR FINAL CHOICE

Even after carefully reviewing the requirements, you'll likely find that there are two or more good candidates for each joinery job. How do you choose between them? There is a brilliantly simple rule of thumb that many experienced woodworkers use to cut through this Gordian knot of joinery. But before I let you in on this secret, let me tell you a brief story.

Several years ago, I wrote a piece on reproducing a Chippendale block-front desk. The original was built in 1765 in Newport, Rhode Island — possibly by the master colonial cabinetmaker/woodcarver, Edmund Townsend. The desk had just sold at auction for over half a million dollars. (SEE FIGURE 1-24.)

As I researched the desk, I ran across an old magazine article by an accomplished woodworker who had built a similar piece. His account of the project was daunting. "Complex" was too mild a word to describe the joinery. The bracket feet, for example, were assembled with double-blind mitered dovetails! I've never met a woodworker who managed to complete a double-blind mitered dovetail in his lifetime,

but I understand the effort required is in the same order of magnitude as the Lewis and Clark expedition.

Next, I visited the head craftsman of the restoration shop at Sotheby's — the outfit that had sold the desk. In interviewing him, I found he had replaced one of the bracket feet. I was awed. I was in the presence of a woodworking deity! What advice did this Olympian have for mere mortals faced with the task of making double-blind mitered dovetails?

"Oh, you read *that* article," he said with a laugh. Then he went on to explain, "Townsend was in the cabinetmaking business, and like most businessmen, he was concerned with production. He didn't have time to spend on over-engineered joinery."

So how did the great Edmund Townsend join the bracket feet on his half-million-dollar desk?

"A simple miter and a glue block."

So here's the secret: When choosing among the myriad woodworking joints, remember that *plain often does just as well as fancy*. In many cases, it will do better.



1-24 Chippendale blockfront desks made by the Townsend family of Newport, Rhode Island, are among the finest and most valuable pieces of eighteenth-century American furniture. Although these desks are elegantly crafted, the joinery is surprisingly simple.

FIVE CUTS

If you have any remaining doubts about how simple and straightforward wood joinery really is, consider this: There are only five joinery cuts! Every fitted joint is made with these:

- A *butt cut* involves a sawed end, edge, or face that is square to the adjoining surfaces.
- A *miter cut* leaves a sawed surface at an angle other than 90 degrees to one or more of the adjoining surfaces.

- A *rabbet cut* makes an L-shaped notch in an arris, or edge, of the board. The bottom and side of the rabbet are usually square to one another.

- A *dado cut* creates a U-shaped channel in one surface. Like a rabbet, the bottom and the sides of a dado are usually square.

- A *hole* or "round mortise" is a cylindrical cavity bored into the wood. Holes can be drilled at any angle. When making these five cuts, you can saw or drill

BASIC WOODWORKING CUTS

THROUGH

BUTT

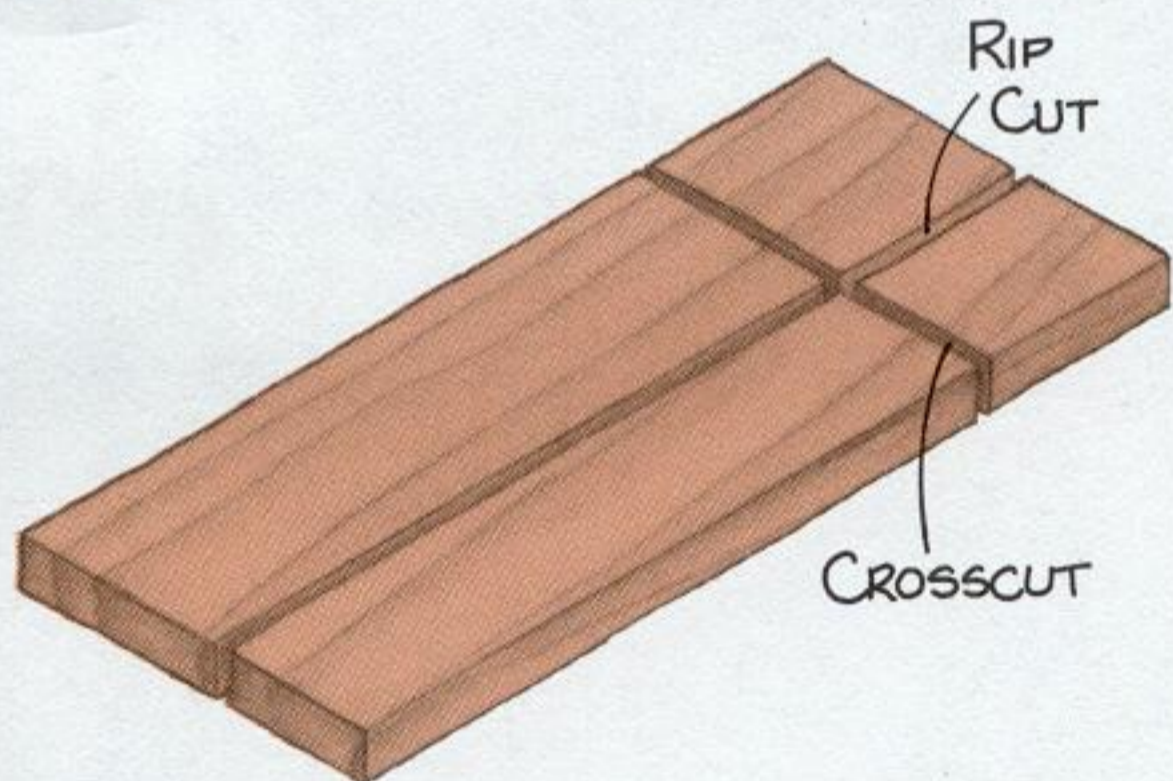

BLIND

BUTT

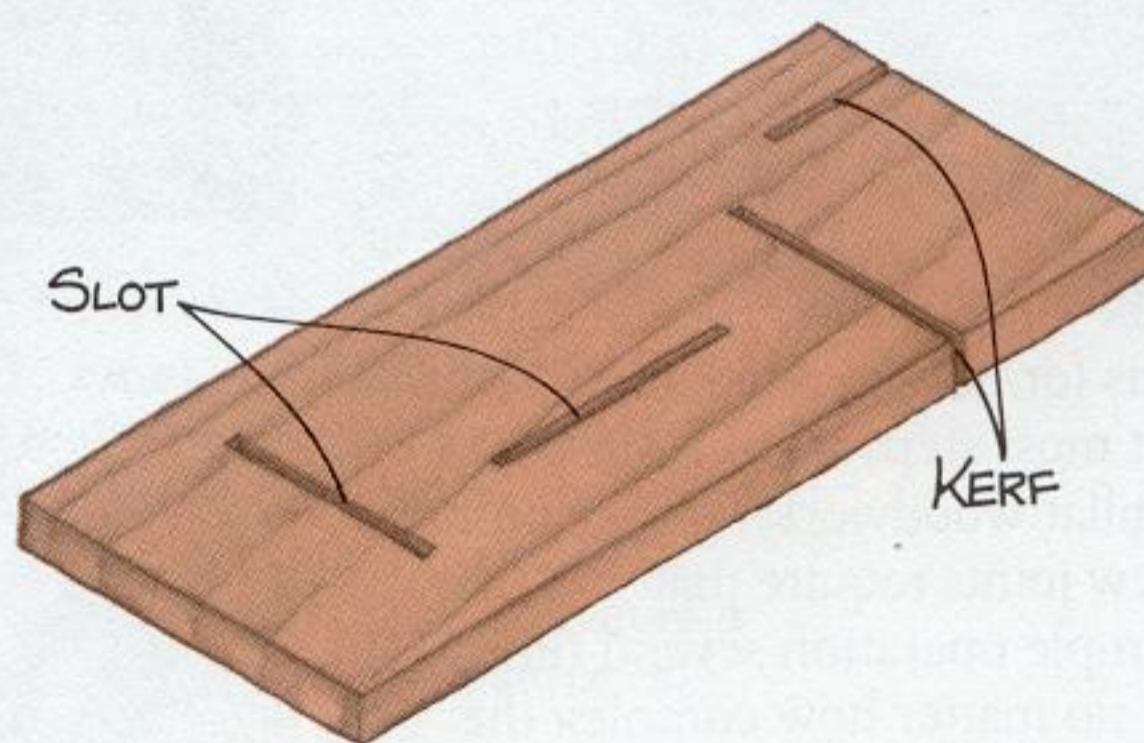

MITER

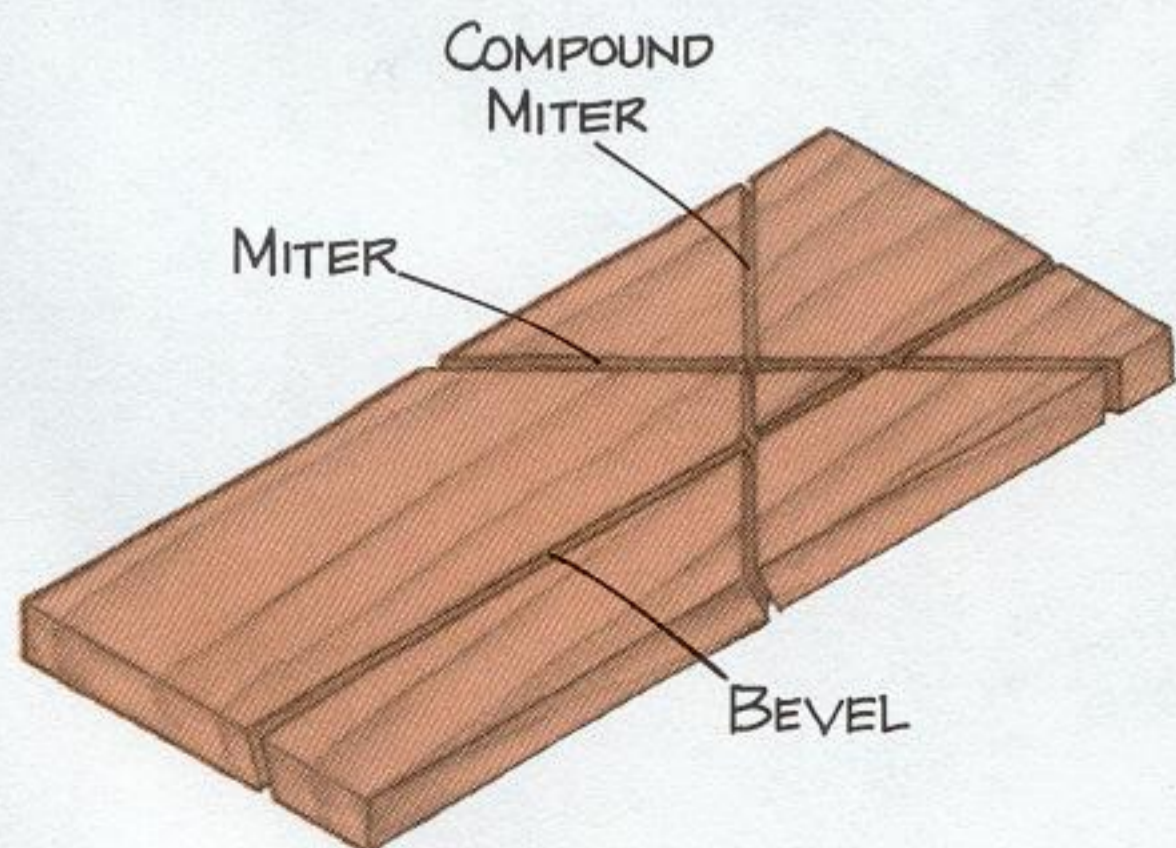

MITER

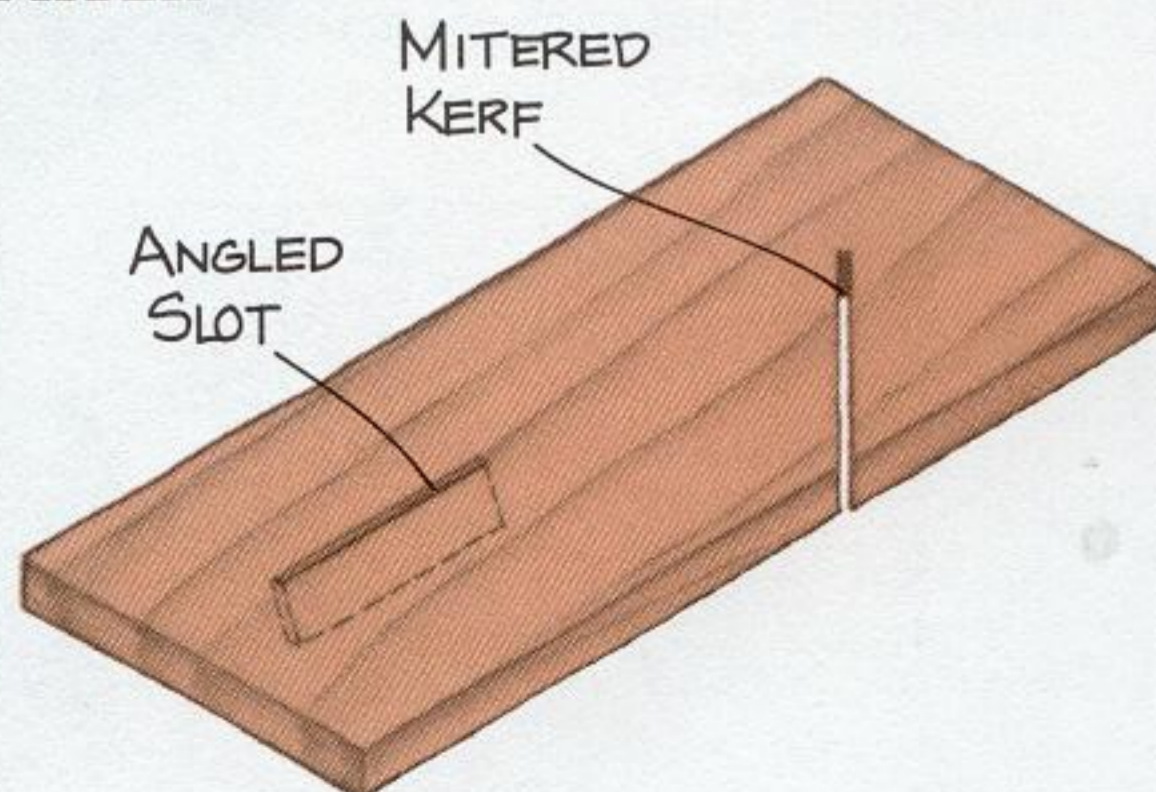

completely *through* the board, or you can halt partway through the cut, making it *blind* or *stopped*. When a cut is blind, its *length* is limited (like a blind alley). A blind rabbet is closed at one end; a double-blind dado is closed at both ends. "Stopped" refers to the *depth* of the cut and usually applies to holes. A stopped hole has a bottom; it doesn't run through the board.

Every woodworking joint, no matter how complex it might appear, is composed of these simple cuts. For

example, a lap joint is made by fitting two dadoses to one another. The mortise in a mortise-and-tenon joint is a double-blind, stopped dado; the tenon is formed from a butt cut (to cut the end of the tenon square) and two or more rabbet cuts. A dowel joint is made of several butt cuts and stopped holes. The trick to making a well-fitted joint is not in making difficult cuts, but in making very simple cuts precisely and in the proper sequence.

THROUGH

BLIND

RABBET

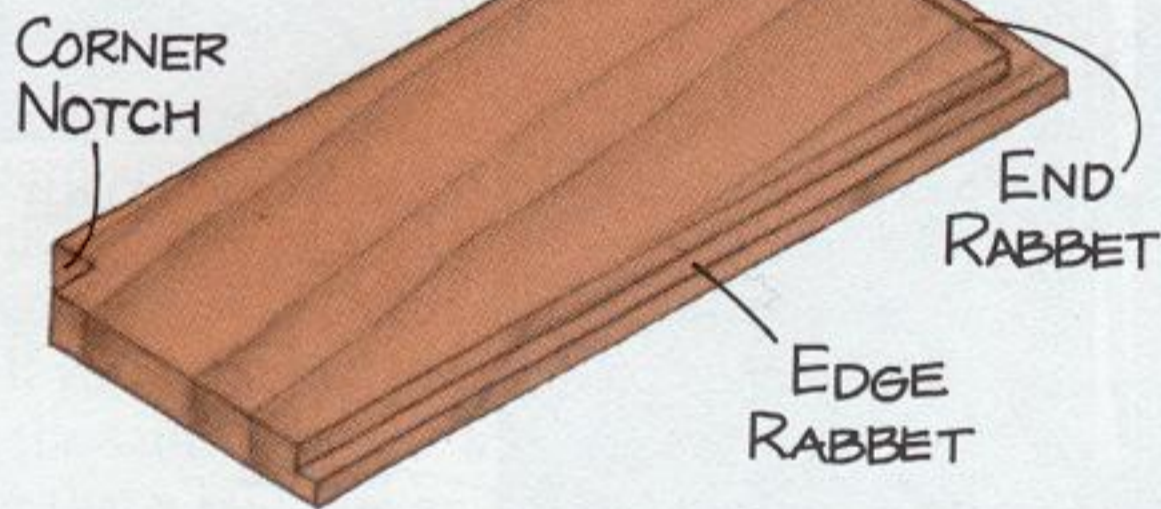

RABBET

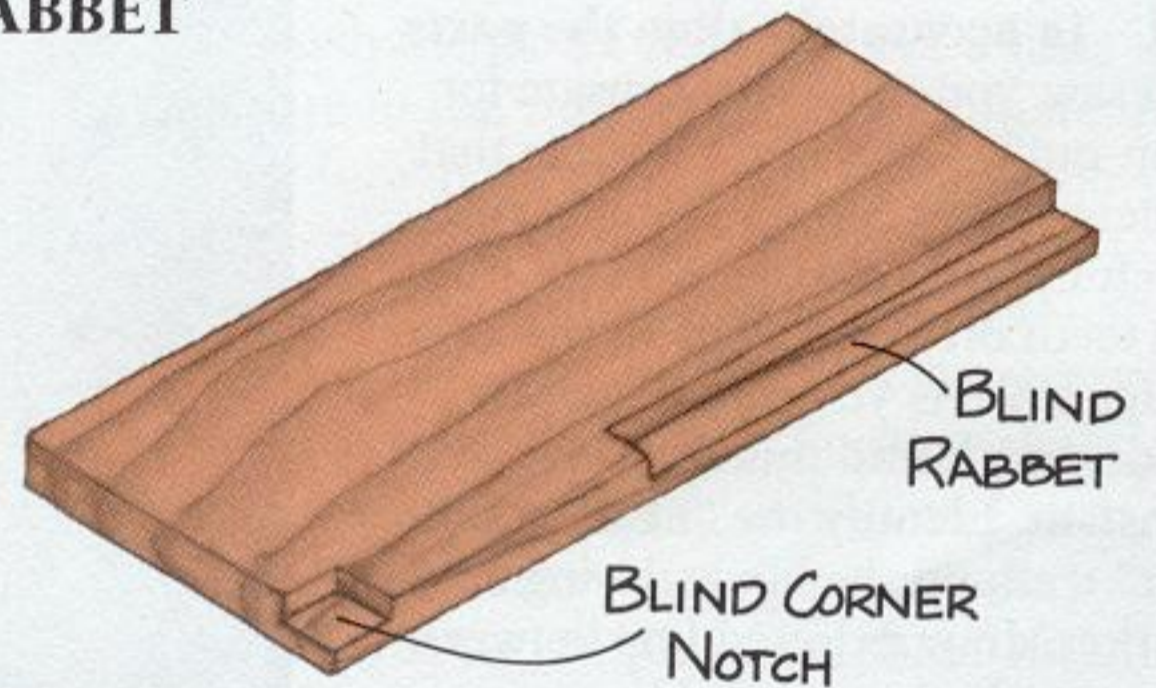

DADO

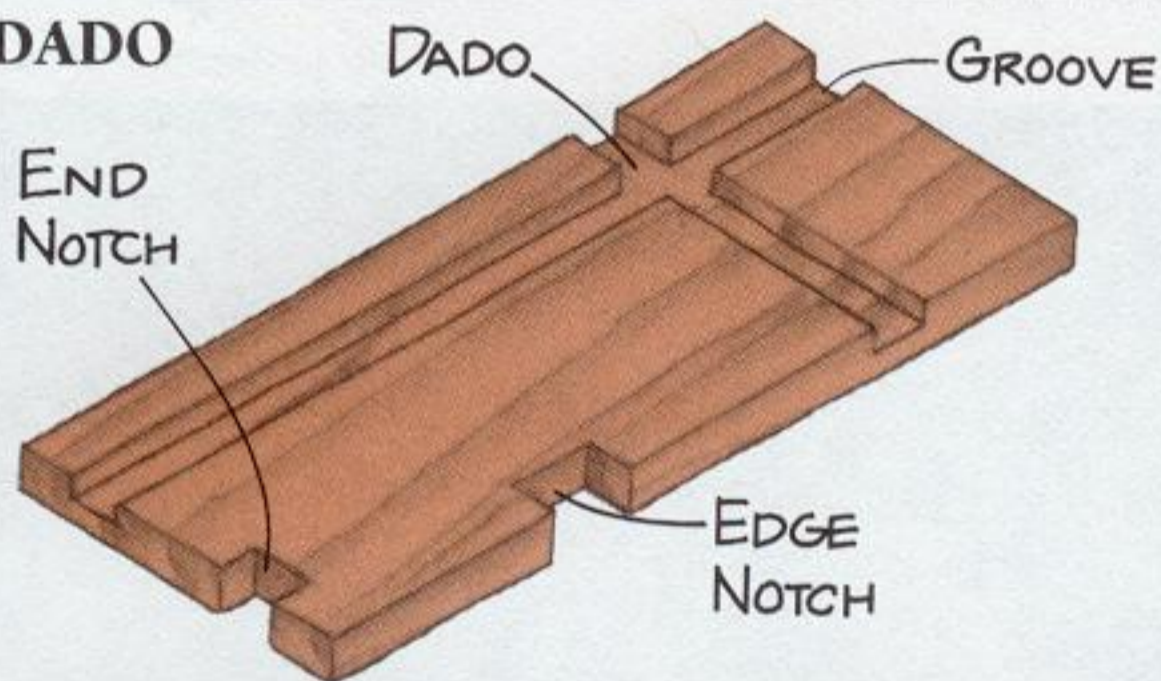

DADO

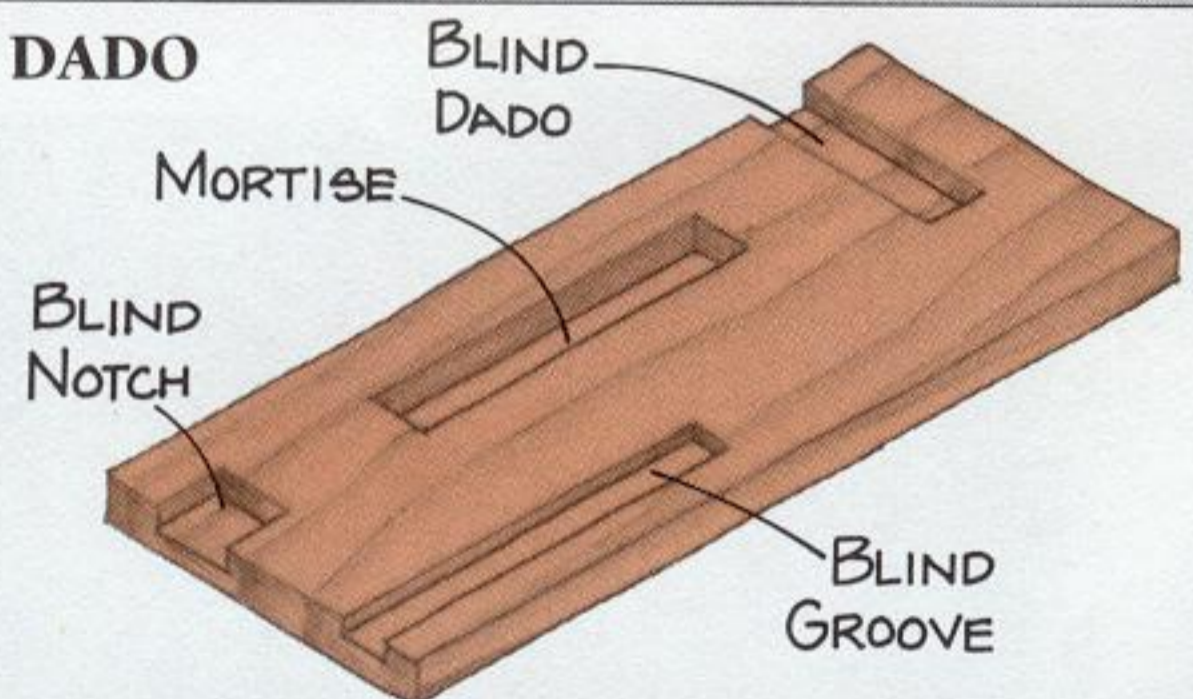

HOLE

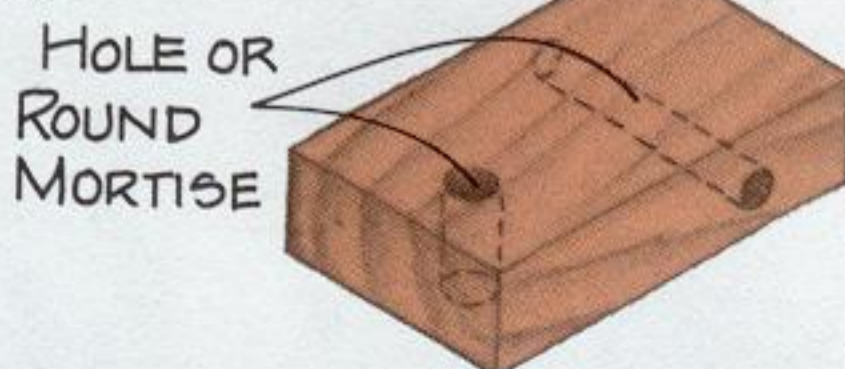

HOLE

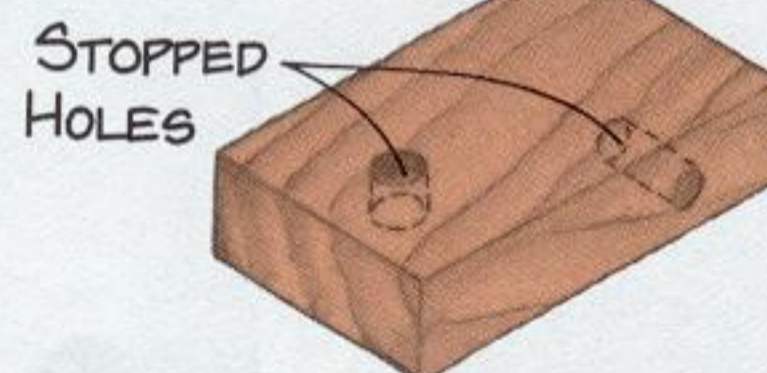

MAKING BUTT CUTS

When making a butt cut — or any joinery cut for that matter — the first step is to check the alignment of the tool. The saw blade *must* be perpendicular to the saw table. (SEE FIGURES 3-1 AND 3-2.) In addition, when making a cross cut (on a table saw), the miter gauge must be perpendicular to the saw blade. For a rip cut, the fence or guide must be parallel to the blade. Use squares, drafting triangles, or rules to check these alignments.

After checking the alignments, position a board on the saw. With the saw turned off, advance the board until it touches the blade. Check that the layout lines on the board are properly aligned with the blade teeth. In some cases, you may have to transfer the layout lines from one surface to another. It also helps to clearly mark the *waste side* of a layout line — the side on which you want to cut the kerf.

3-1 To accurately align the parts of a saw, you must compensate for “run-out” — the slight wobble that afflicts all saw blades. Using a rule, carefully measure the distance from the teeth on a saw blade to the miter gauge slot. As you rotate the saw blade, you’ll find this distance isn’t constant. Identify the “near” and the “far” teeth on the blade. Using a marker, draw a dotted line between these teeth, then a solid line perpendicular to the first. Both lines should pass through the center of the blade.

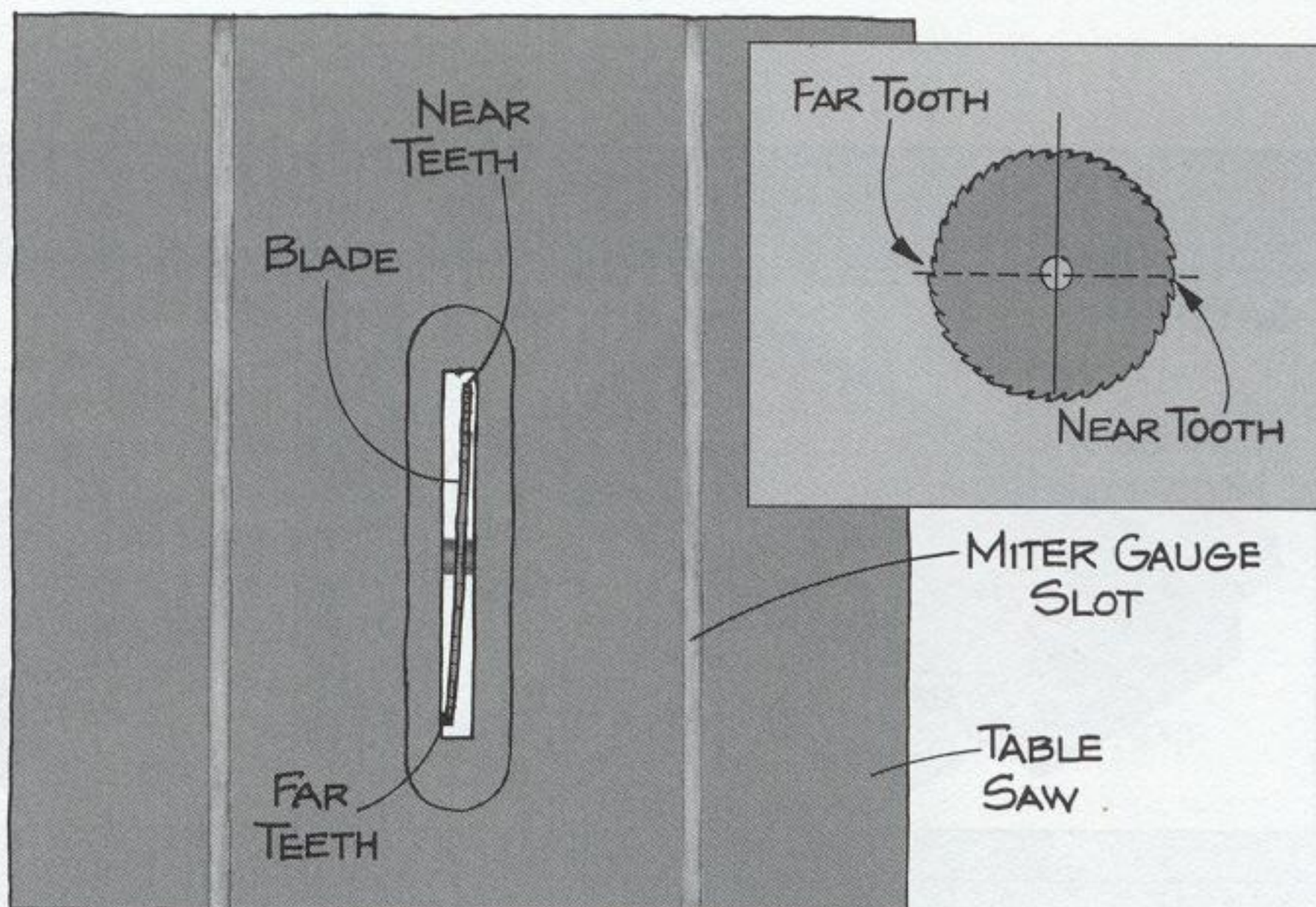

3-2 When checking the saw alignments, lay the square or triangle against the *solid* line on the blade. Or, measure from the teeth at either end of this line. These points will provide more accurate references than any others on the blade.

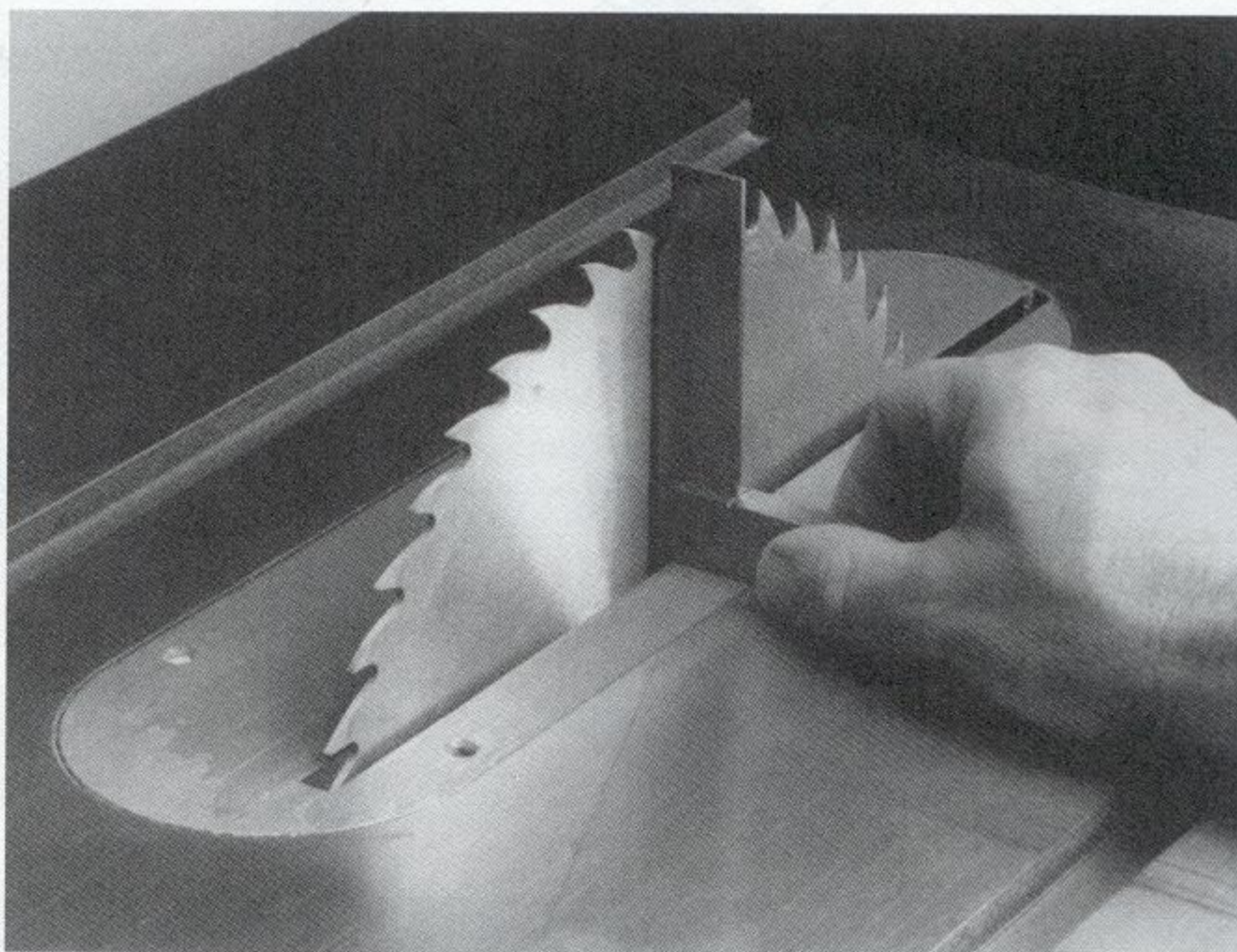



TRY THIS TRICK

When crosscutting on a table saw, it's sometimes difficult to position the board. Often, the surface with the layout line faces away from you, and to align this mark with the saw teeth, you must lean over the blade. A better method is to make and use a "third eye." Purchase an inspection mirror at an automotive store, cut off the handle, and mount the mirror on a small wooden base as shown. When you need to see something that faces away from you, place your third eye where it will reflect what you need to see.

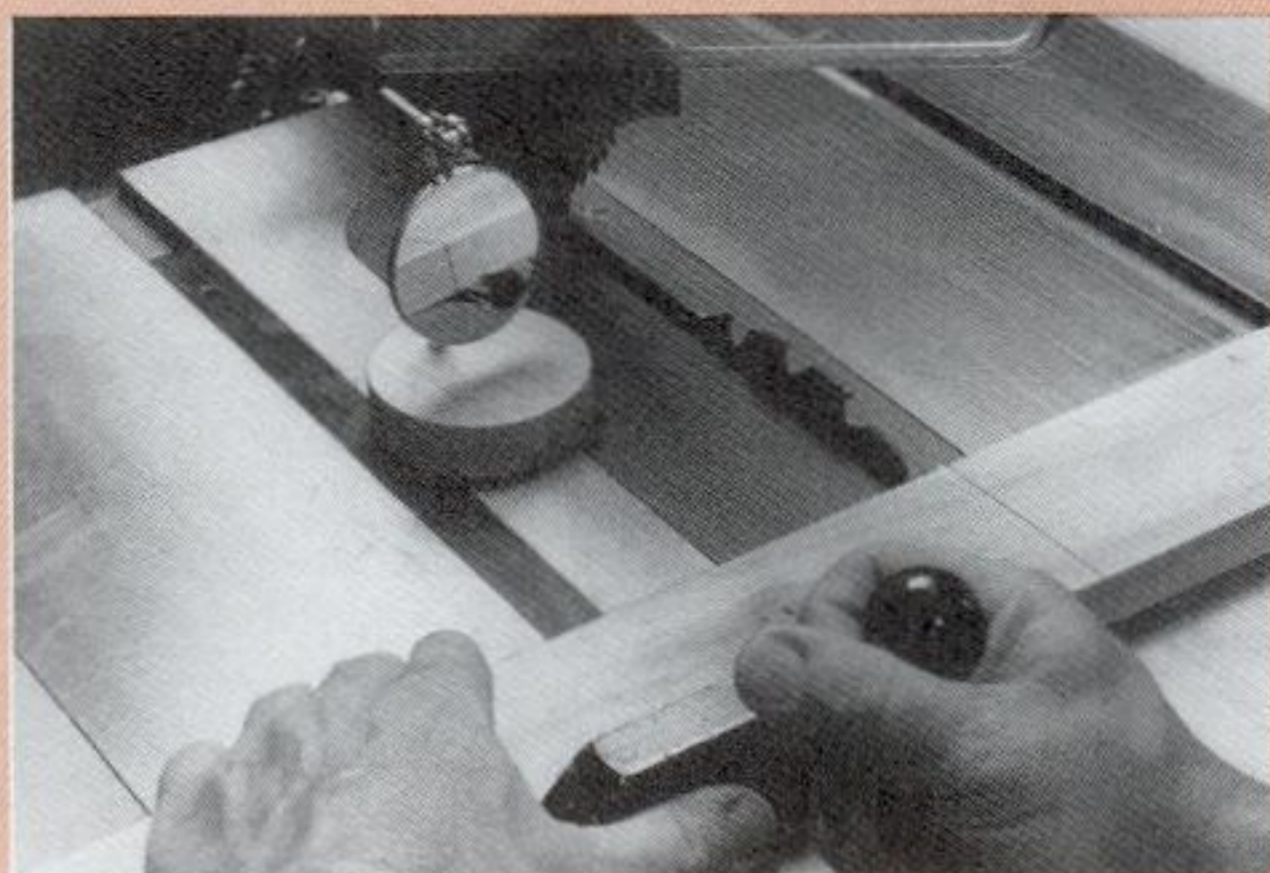

To make a cut, feed the wood into the blade slowly, using a steady, even pressure. Monitor the blade constantly, and slow down if it begins to bog down or vibrate. If the blade binds or burns in the cut, you could have a piece of reaction wood. Discard that board and get another. Vibration, bogging down, binding, and burning can also be caused by improper alignment. Check the tool setup carefully.

If you have to make duplicate cuts, feed each board at the same rate and with the same pressure. Remember that a saw, like any mechanical system, must have some "play." Although a miter gauge may seem snug

in its slot, there has to be a little play or it won't move. As you push the gauge forward, put a little sideways pressure to the right or left to eliminate the play. Remember how hard and in which direction you pressed, then do the same on all remaining cuts.

This is an important technique! It ensures that duplicate cuts are *precise* duplicates, and it preserves the accuracy of your woodworking. Because there will always be a little play in your setups and you usually make more than one cut with each setup, you'll need to use this technique — or some variation of it — over and over again.



FOR BEST RESULTS

For joinery cuts, use a saw blade that leaves as smooth a surface as possible. You have several good choices. *Hollow-ground planer blades* (top) make an extremely smooth cut. However, they require more "projection" than other blades — the teeth must completely clear the work as you cut, or the blade will burn the wood. For this reason, they don't work well on radial arm saws. *Carbide-tipped combination blades* (bottom) with 40 teeth or more are smooth-cutting, require minimal projection, and can be used on both table saws and radial arm saws. Finally, *thin-kerf blades* (middle) also leave smooth cuts and are as versatile as carbide-tipped blades. They also cut faster with less friction; however, because the blades are so thin, thin-kerf blades are more prone to vibration. You may want to use large, specially made washers called blade stabilizers, available from most mail-order woodworking suppliers.

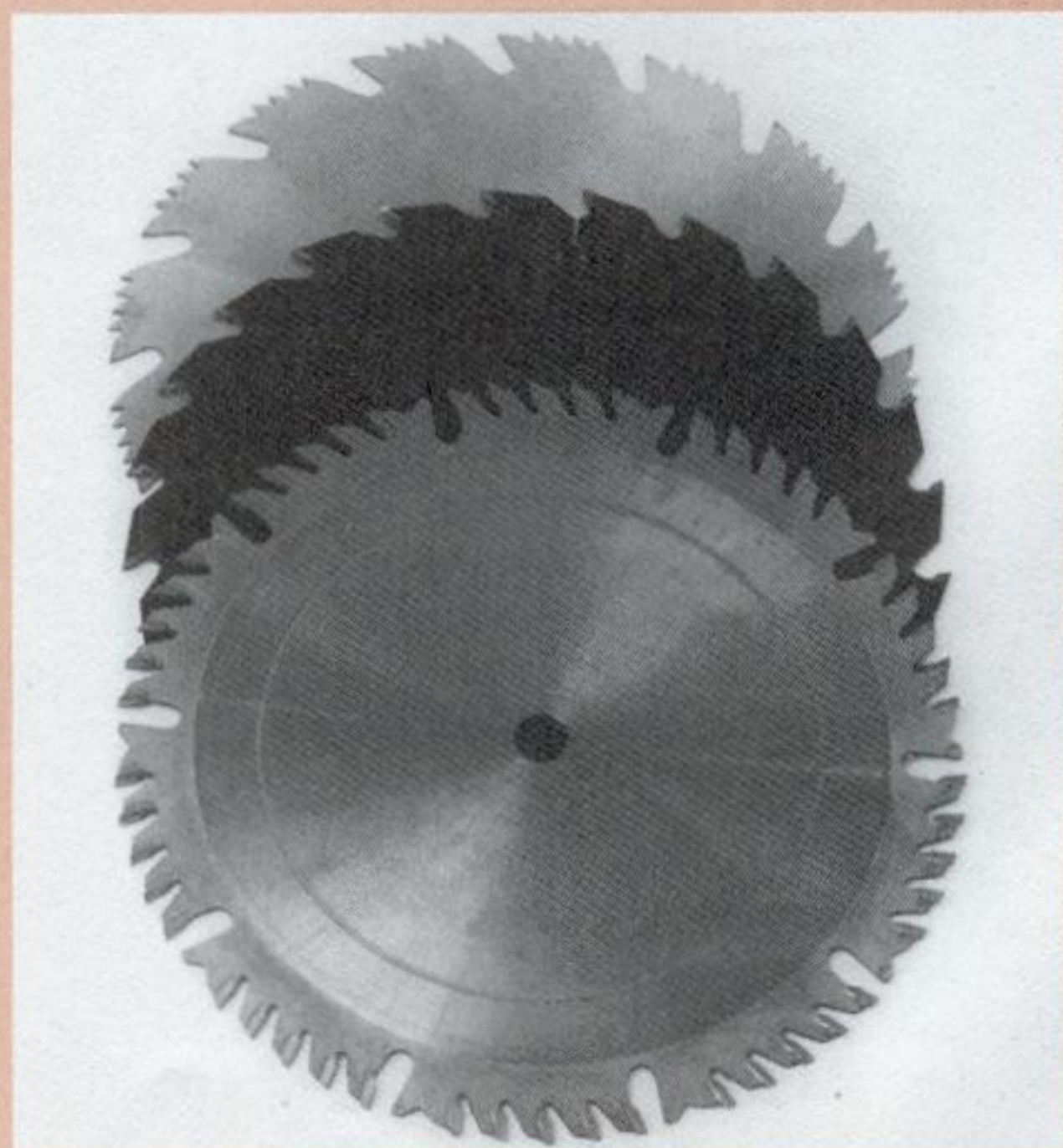

CUT-OFF JIG

Miter gauges offer little support when crosscutting large boards on a table saw. The face of the miter gauge is too small to keep the board properly aligned. You can attach an extension to the face of your miter gauge to gain extra support — some woodworkers fasten an extension between *two* miter gauges — but this is not a perfect solution, either. You must still contend with the friction of the wood as it slides across the worktable.

A cut-off jig solves both problems — it provides adequate support for large boards *and* relieves the friction. The sliding table of this particular cut-off jig is a large slab of medium-density fiberboard (MDF). (I used MDF because it remains very flat.) Two acrylic plastic runners ride in the miter gauge slots, guiding the jig's table back and forth across the table saw. A fence backs up the boards as you cut them.

This particular cut-off jig has several special fea-

tures. If you want to make duplicate cuts, the fence is grooved so you can mount a stop anywhere along its length. The grooved portion of the fence — the fence extension slide — can be extended to position the stop up to 36 inches away from the blade. If you want to hold the board down while you cut it, you can mount a clamp on the fence. (The straight-line toggle clamp shown is available from most mail-order woodworking suppliers.) And an acrylic plastic guard protects you from the saw blade.

The construction of the cut-off jig is straightforward. Glue up stock to make the thick piece needed for the stop and the tieblock. Cut the sliding table from MDF; the stop, fence extension slide, fence top, middle, and bottom from solid hardwood; the runners and guard parts from acrylic plastic; and the remaining parts from plywood. **Note:** Make the fence extension slide and

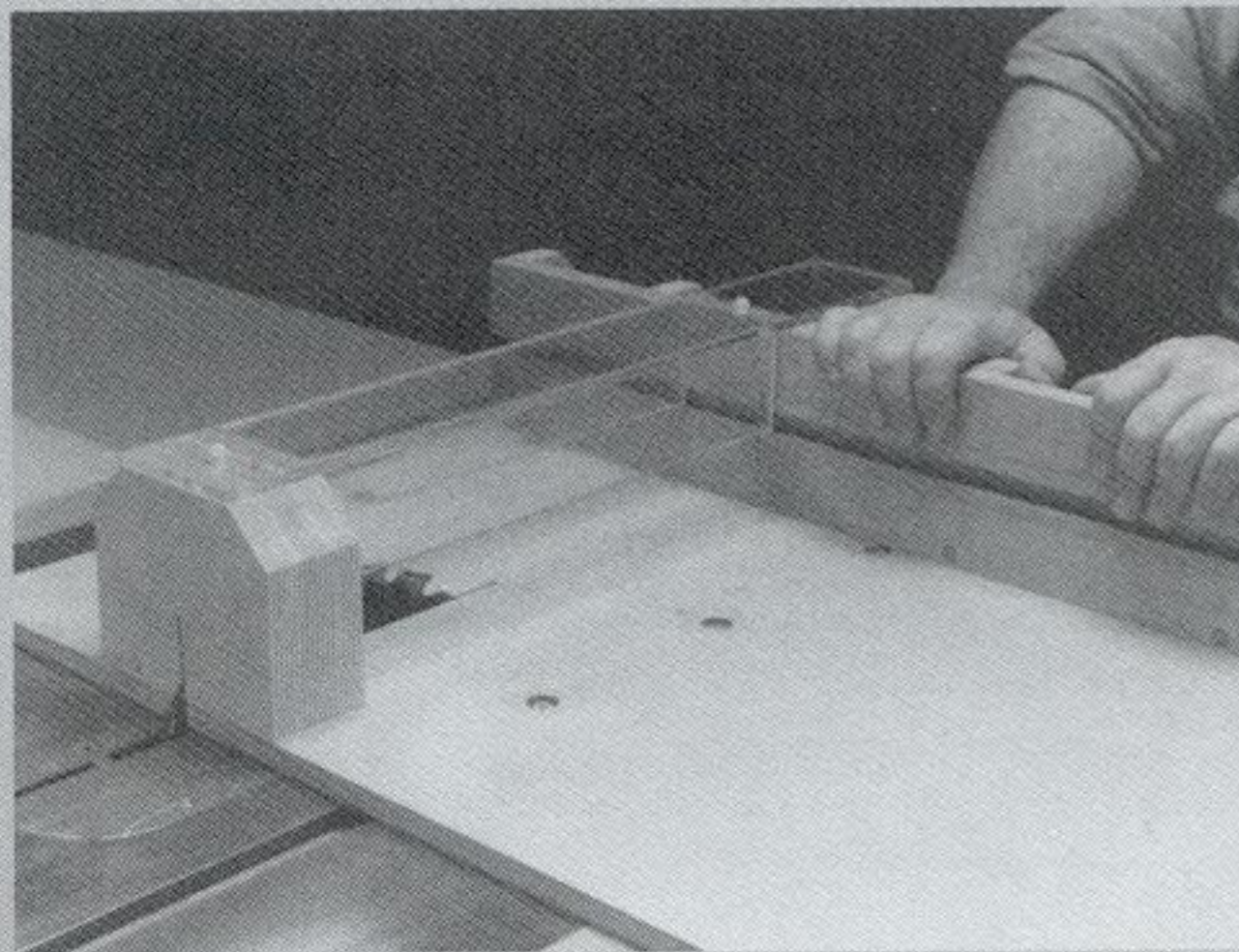

1 Before you can align the fence or use the cut-off jig, cut a slot in the sliding table. Lower the blade beneath the table. Place the jig on the saw, fitting the runners in the miter gauge slots. The sliding table and the fence should straddle the saw blade. Turn the saw on, raise the blade, and push the jig forward, cutting a slot. The fence and the tieblock will keep the table together.

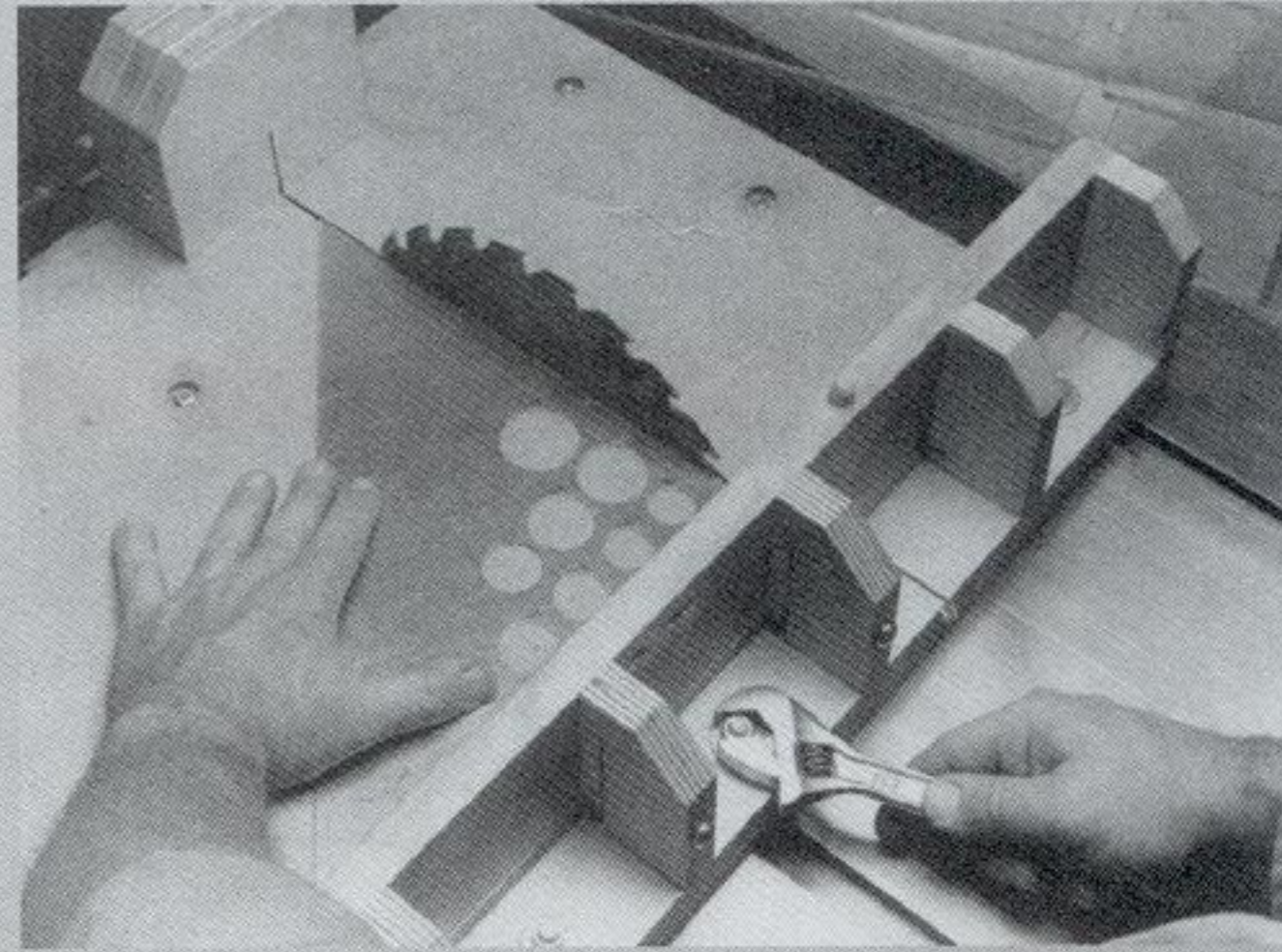

2 Align the fence so it's perpendicular to the blade in the same way you'd align a miter gauge. Raise the blade as high as possible and loosen the bolts that hold the fence to the sliding table. Use a drafting triangle to adjust the fence square to the blade, then tighten the bolts. **Note:** Make sure that the drafting triangle rests against the blade, but not the teeth.

fence middle in one long strip, then cut into two parts *after* routing the joinery.

Rout the grooves and rabbets in the fence parts, as shown in the *Fence Extension Slide Detail*. Cut the fence extension slide/fence middle into two parts, as shown in the *Top View*. Drill the bolt holes in the fence base a little larger than the bolts. This gives you the play necessary to align the fence precisely square to the blade.

Cut and drill five of the seven fence braces as shown in the *Fence Brace Layout*, and install threaded inserts and roundhead stove bolts in the holes. The fingers on these braces hold the fence extension slide in place. As you turn the bolts clockwise, they press the fingers forward and lock the extension in place. Turn them counterclockwise and the fingers spring back so you can easily move the extension. Assemble the fence with glue and flathead wood screws. Be careful *not* to glue

the fence extension slide in place.

Cut and drill the stop as shown in the *Stop* drawings. Pay careful attention to the wood grain direction — it should be *parallel* to the stop's fingers. One face of the stop is pointed (as shown in the *Stop/Top View*) to keep sawdust from becoming trapped between the stop and the stock when making duplicate cuts.

Attach the tieblock to the sliding table with glue and flathead wood screws. Bolt the runners, fence assembly, and clamp assembly to the sliding table, but do *not* glue them in place.

Cut and drill the parts of the guard as shown in the *Guard* drawings. Note that one of the mounting holes is slightly larger than the other. This makes it possible to shift the fence slightly when you align it with the blade. Assemble the plastic parts with acrylic glue. Install a dowel in the fence and another in the tieblock to hold the guard in place.

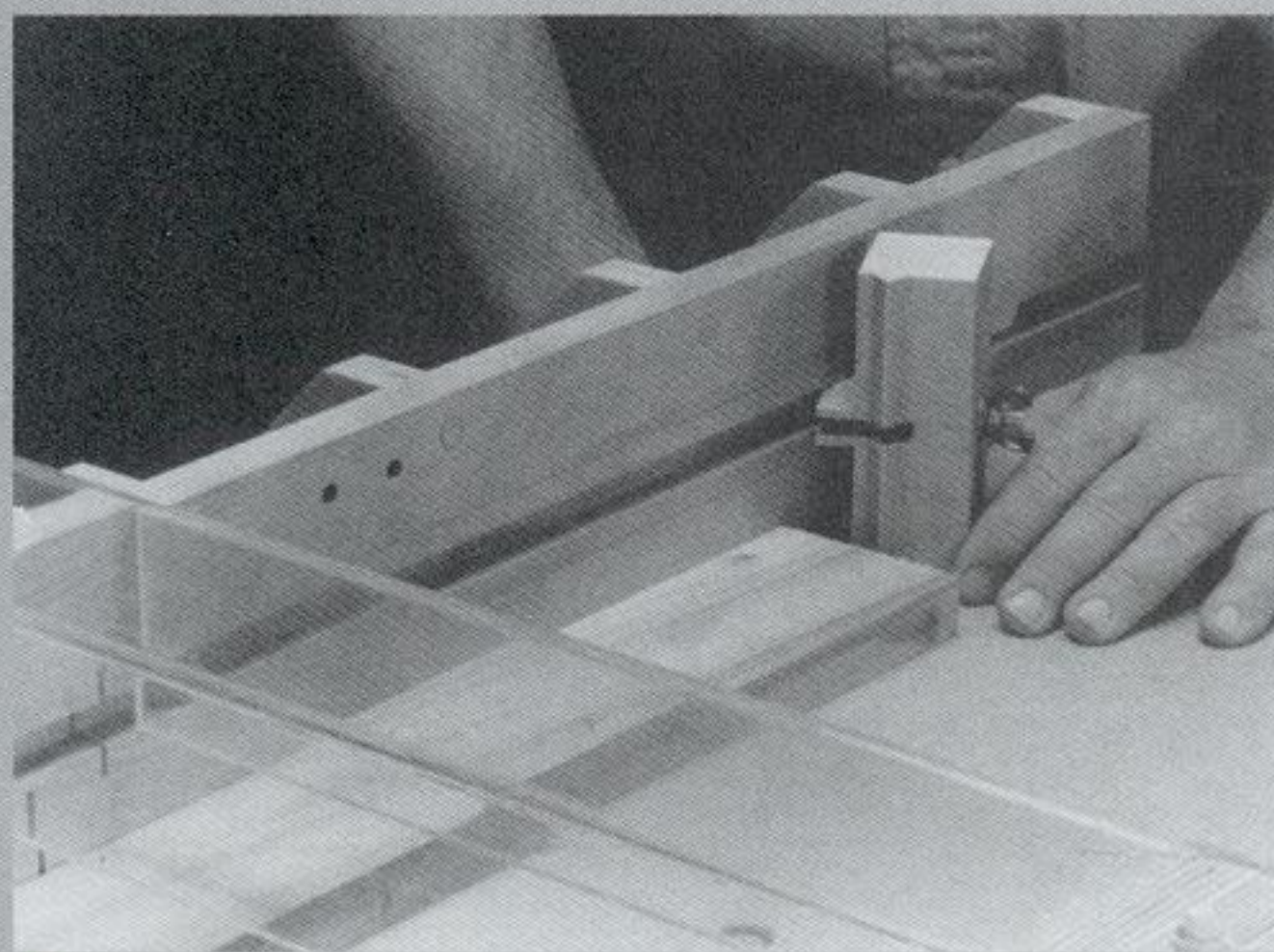

3 Use the cut-off jig as you would a miter gauge. Rest a board against the fence, then slide the jig forward, past the blade. If you want to make duplicate cuts, secure the stop block to the fence by turning the wing nut. The block mounts in a groove in the fence.

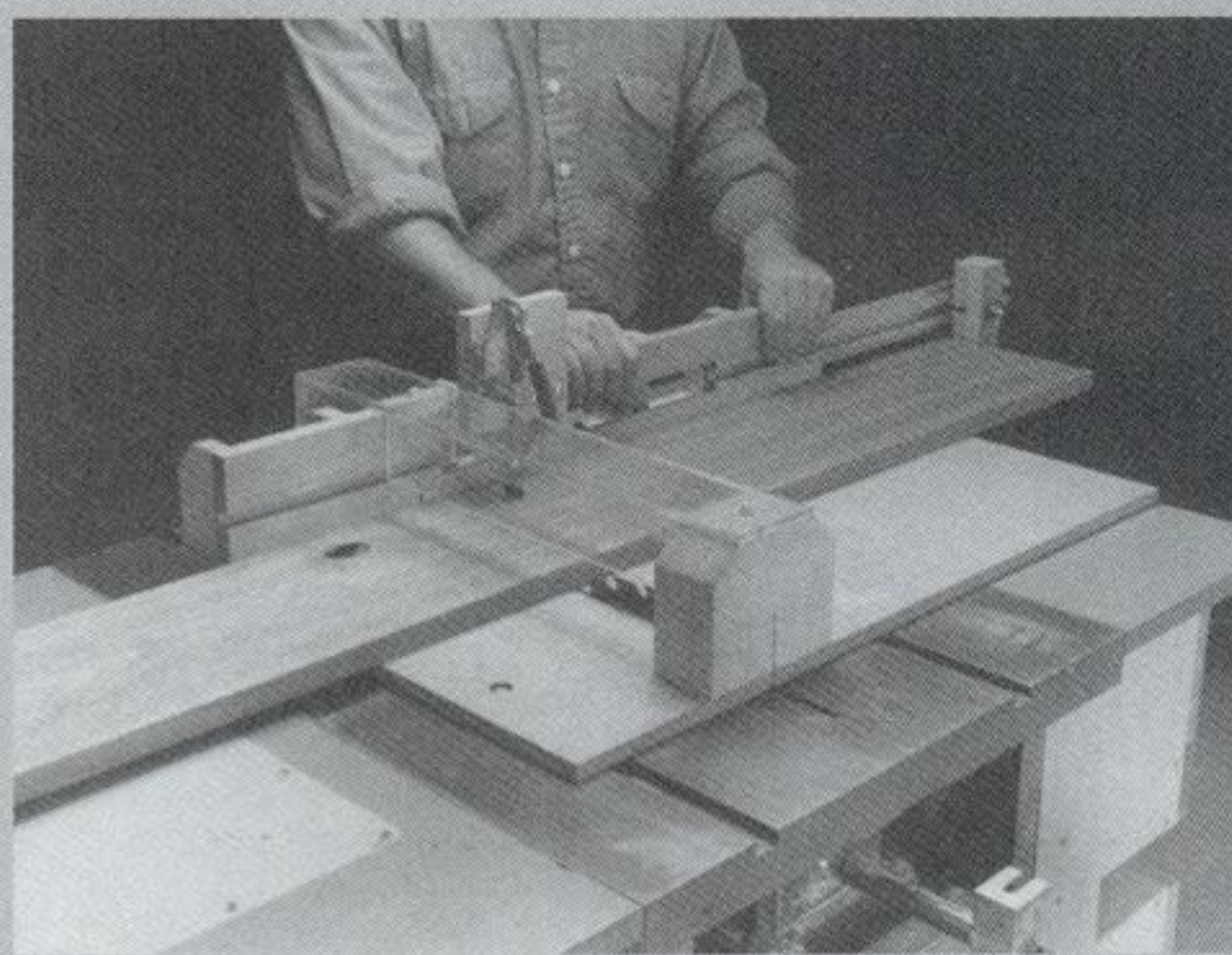

4 If you need to make duplicate cuts longer than the fence, pull the fence extension slide sideways and lock it in place. The stop block groove in the middle portion enables you to mount the stop block out past the table.

CUT-OFF JIG — CONTINUED

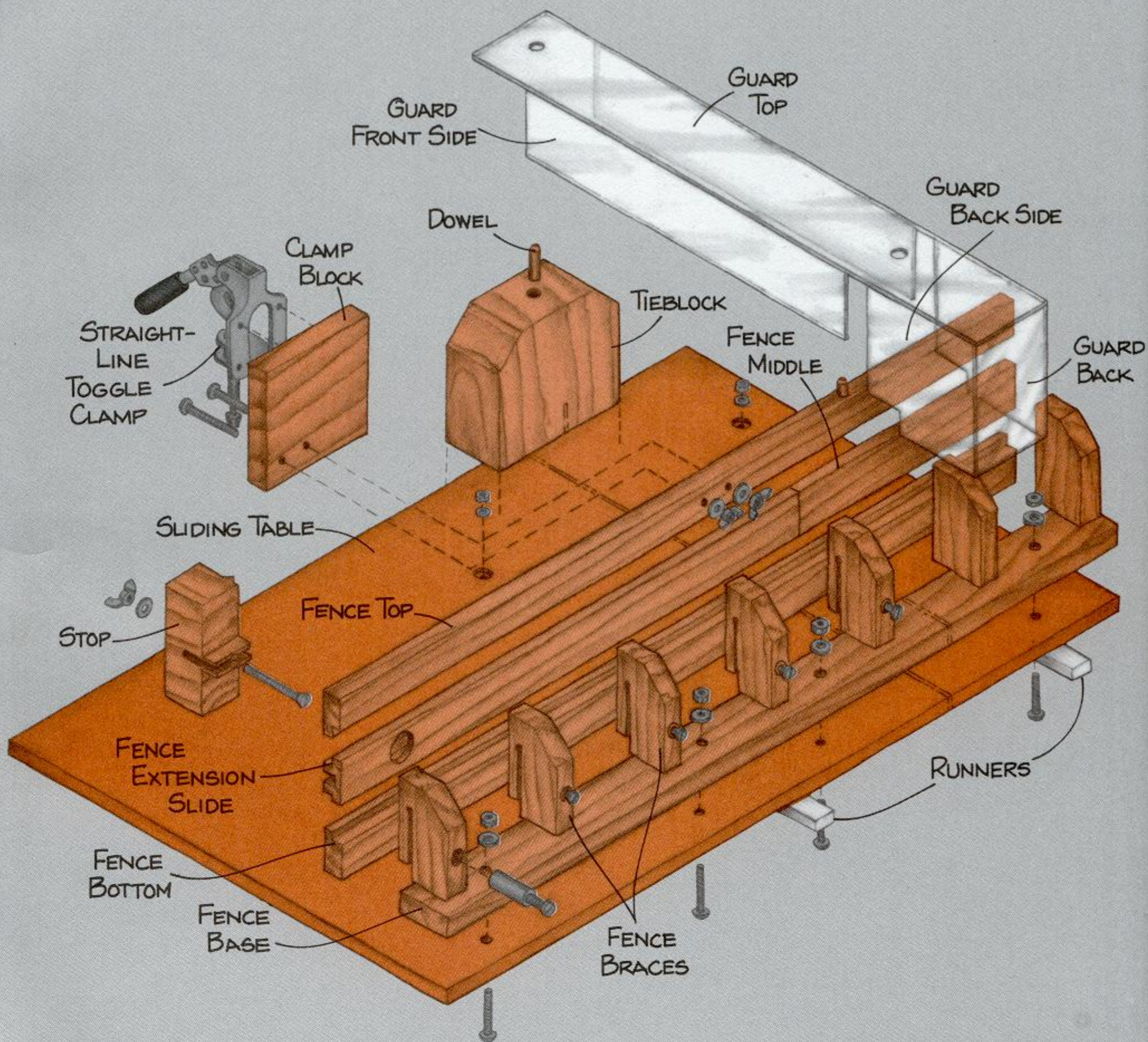

EXPLODED VIEW

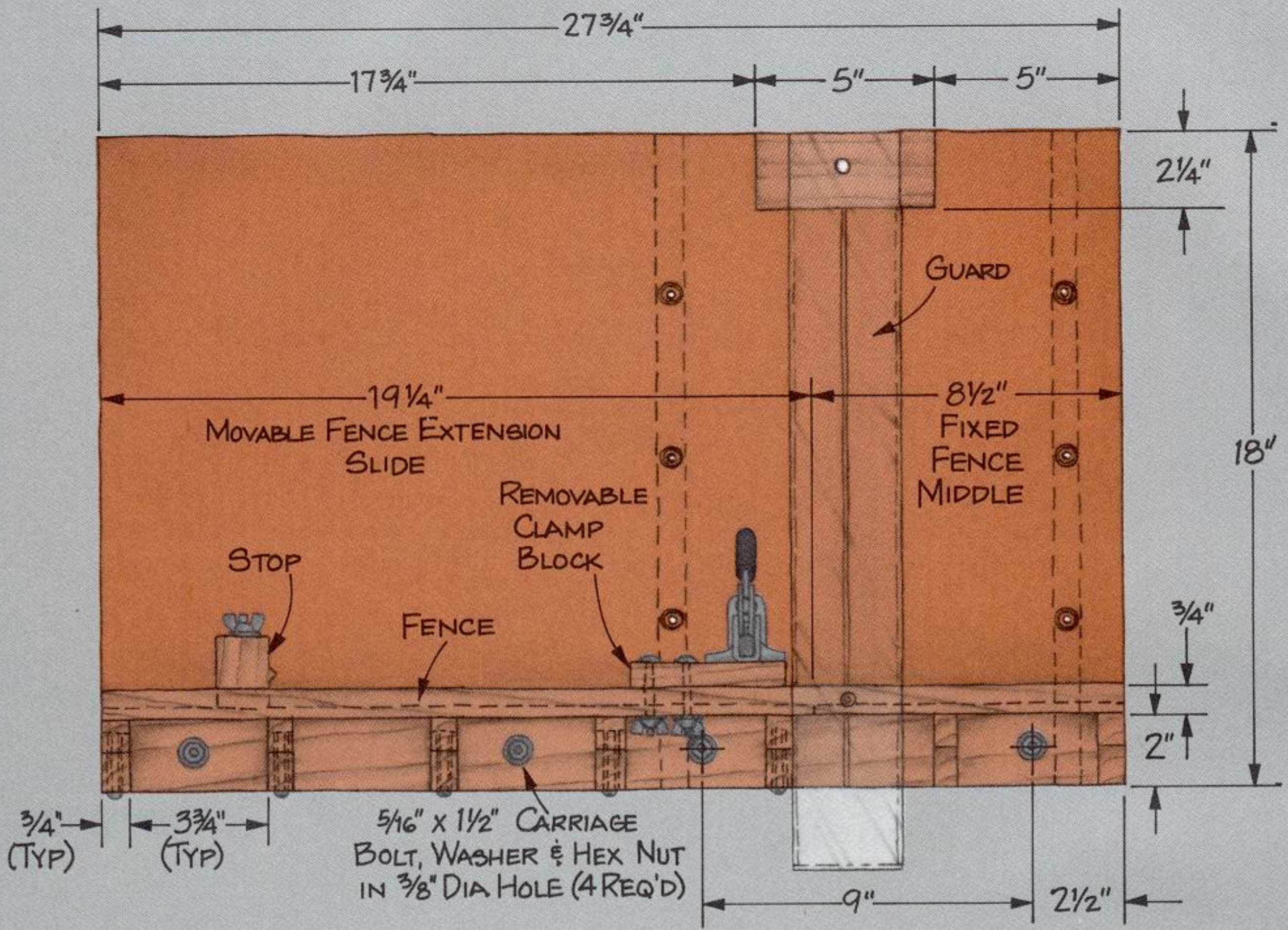

TOP VIEW

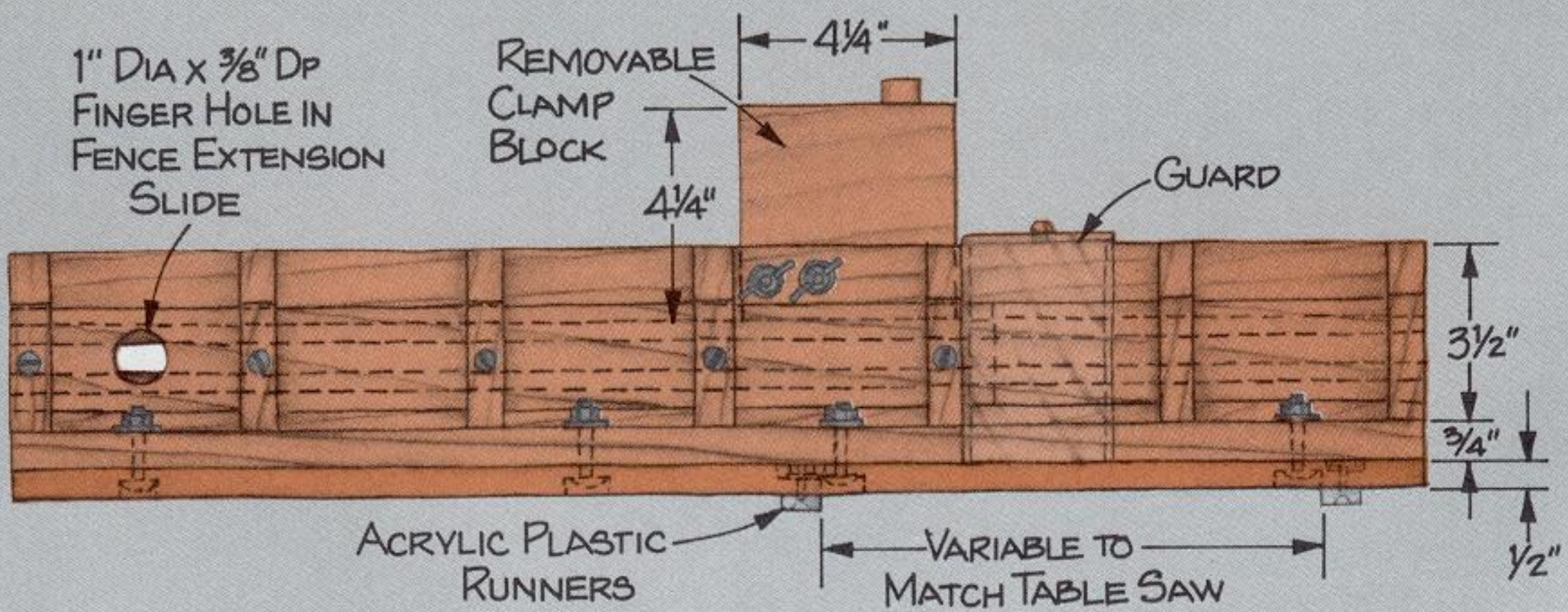

FRONT VIEW

CUT-OFF JIG — CONTINUED

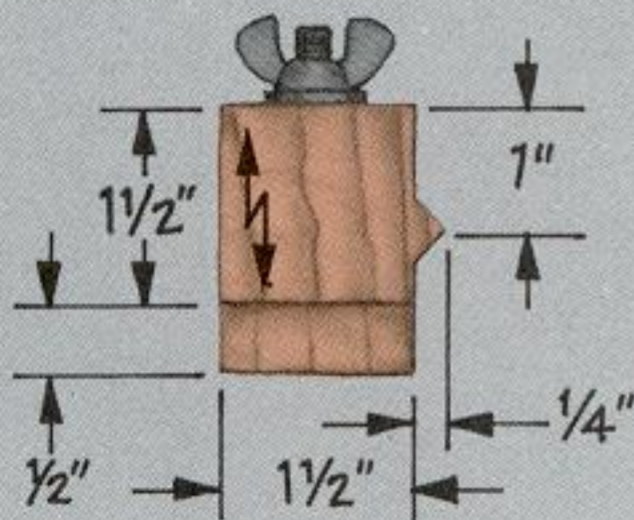

TOP VIEW

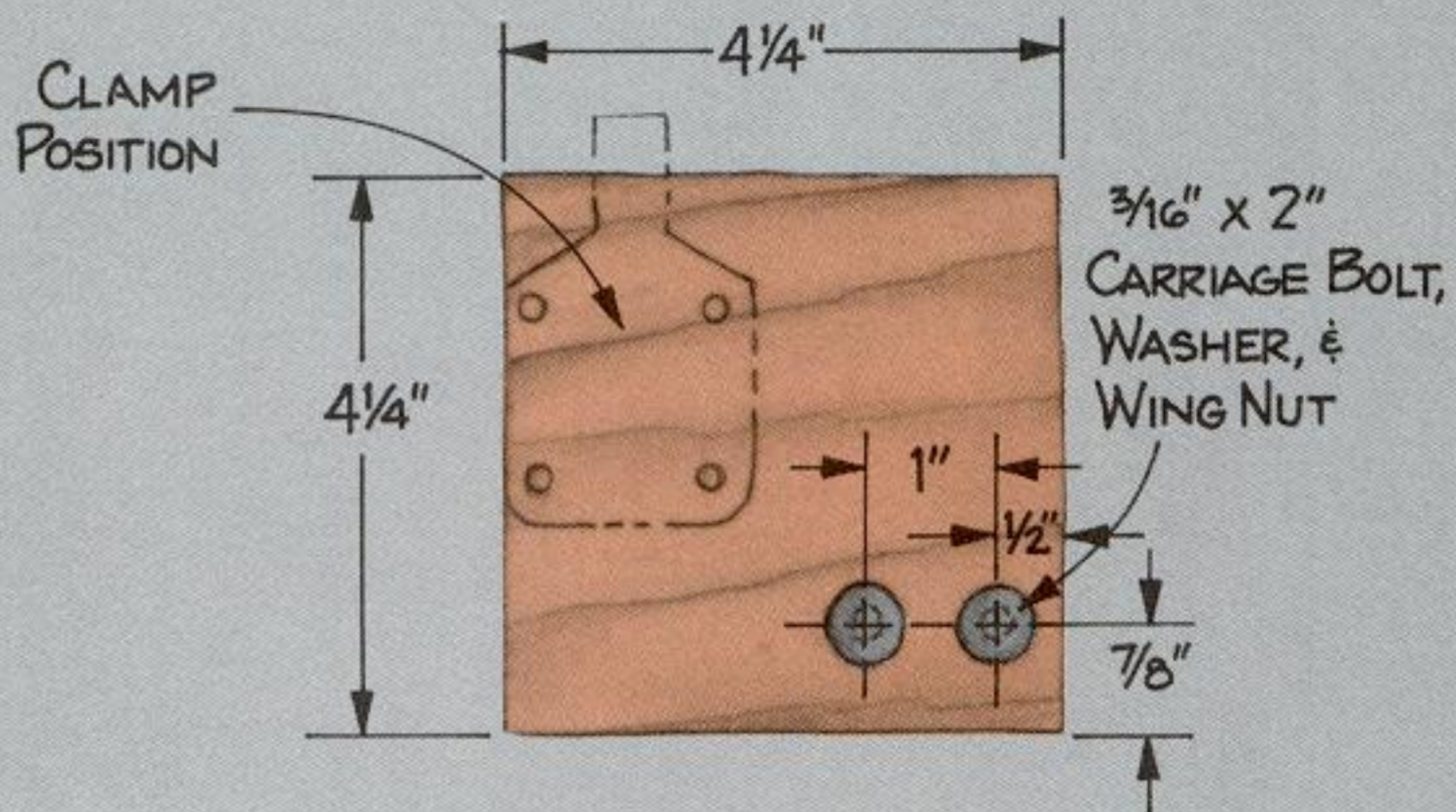

CLAMP BLOCK LAYOUT

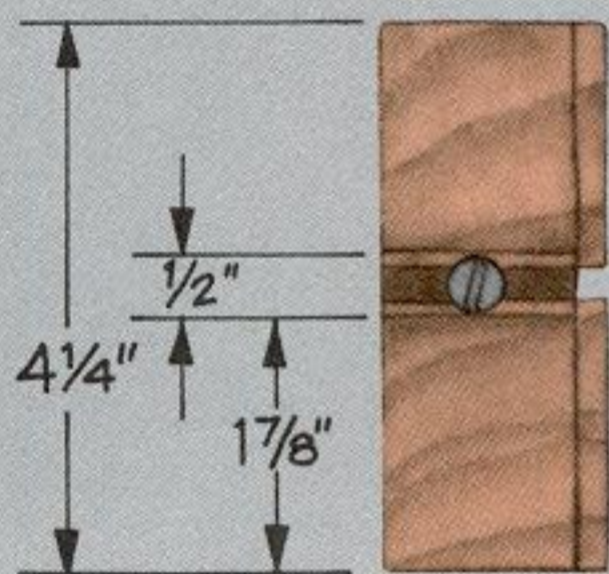

FRONT VIEW

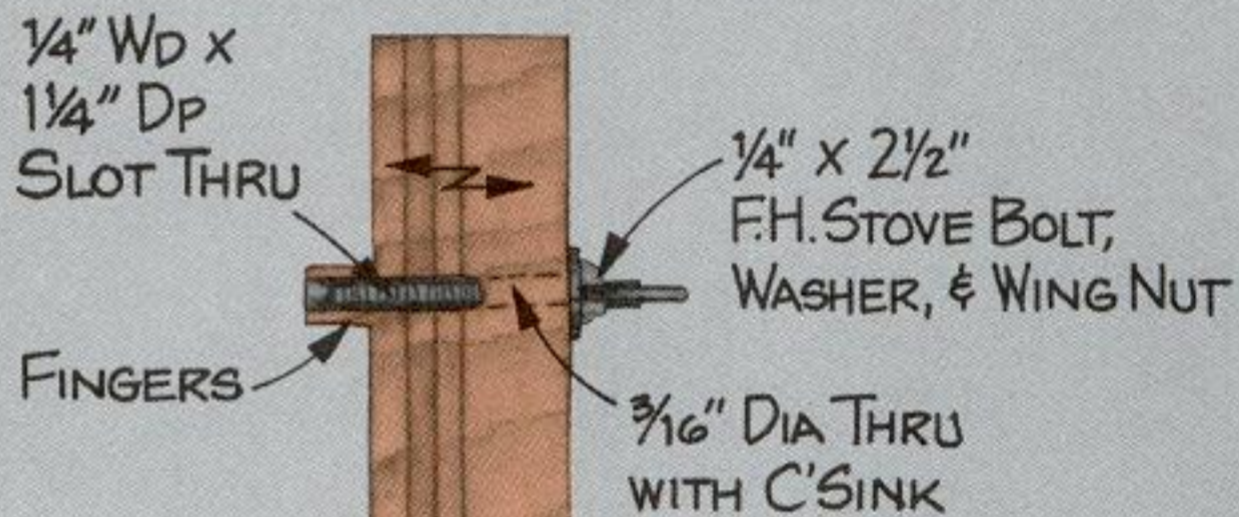

SIDE VIEW

STOP

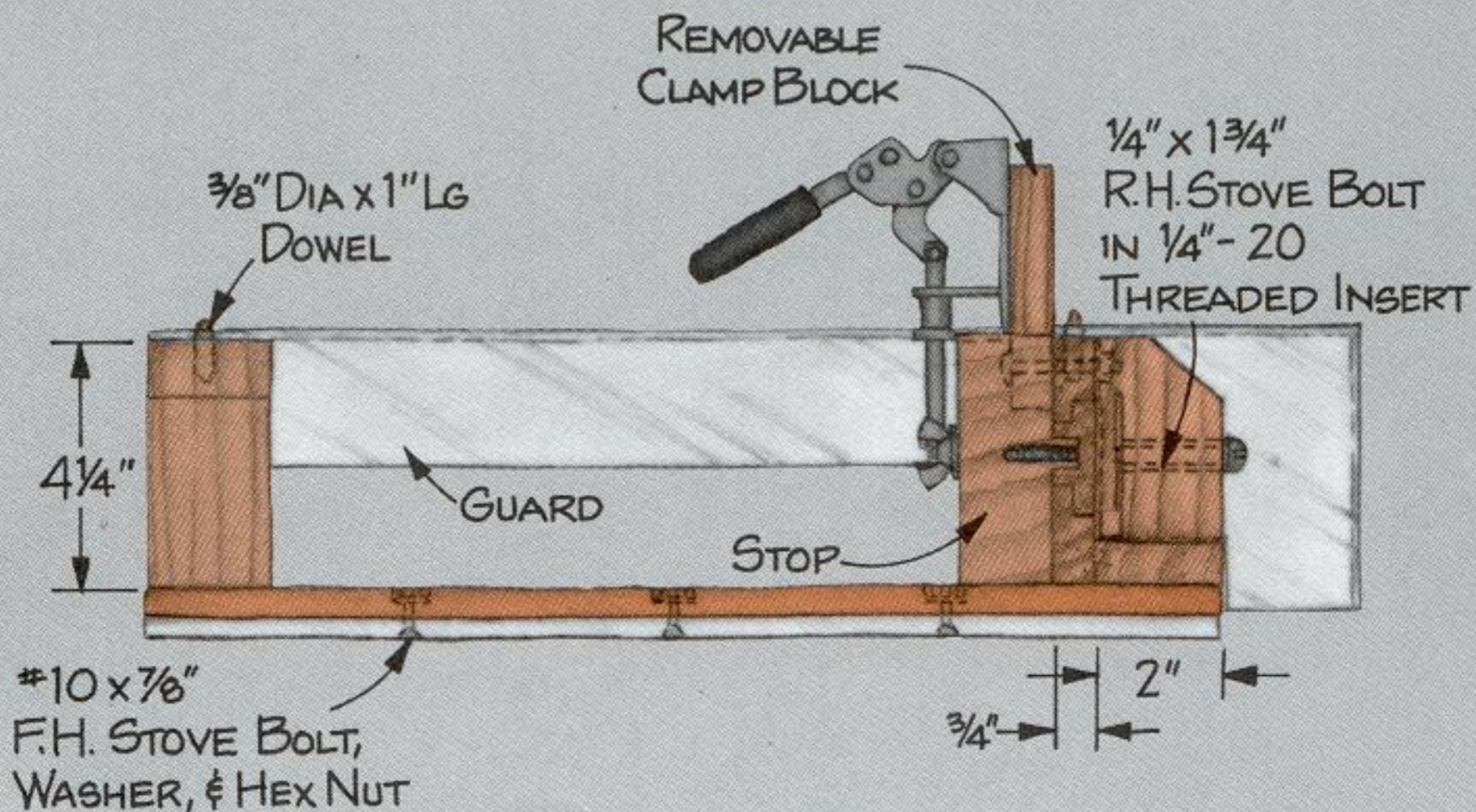

SIDE VIEW

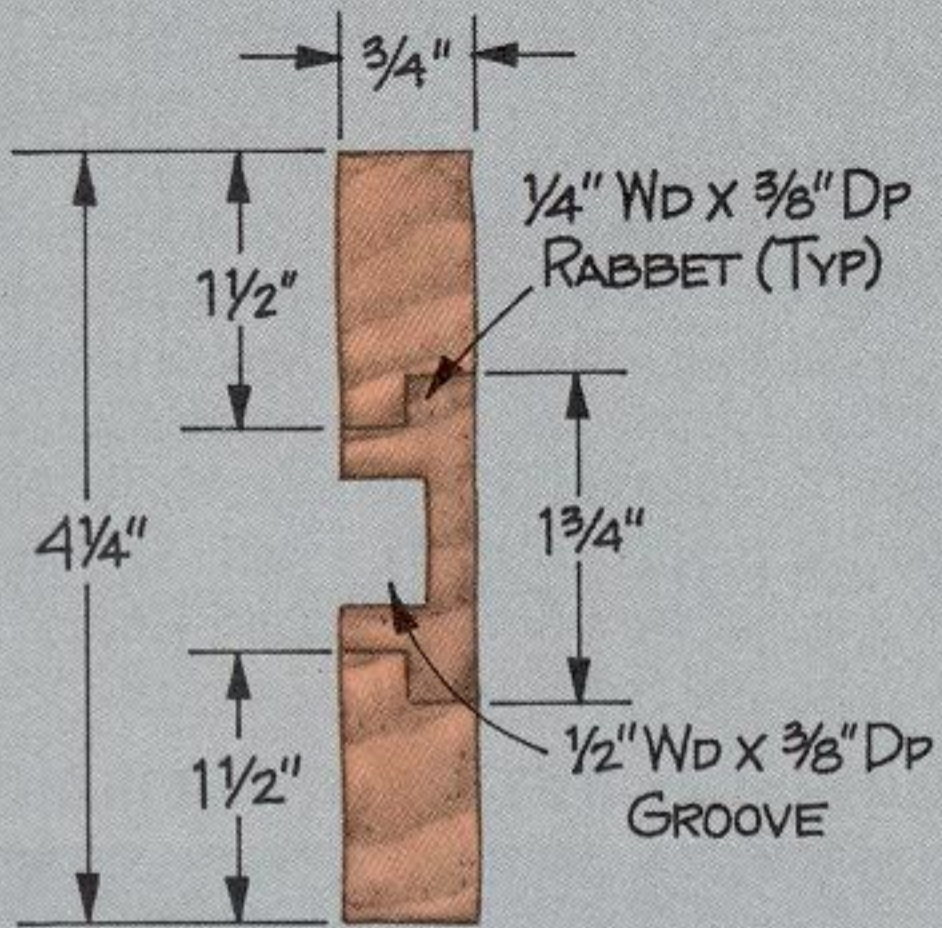

END VIEW

FENCE EXTENSION
SLIDE DETAIL

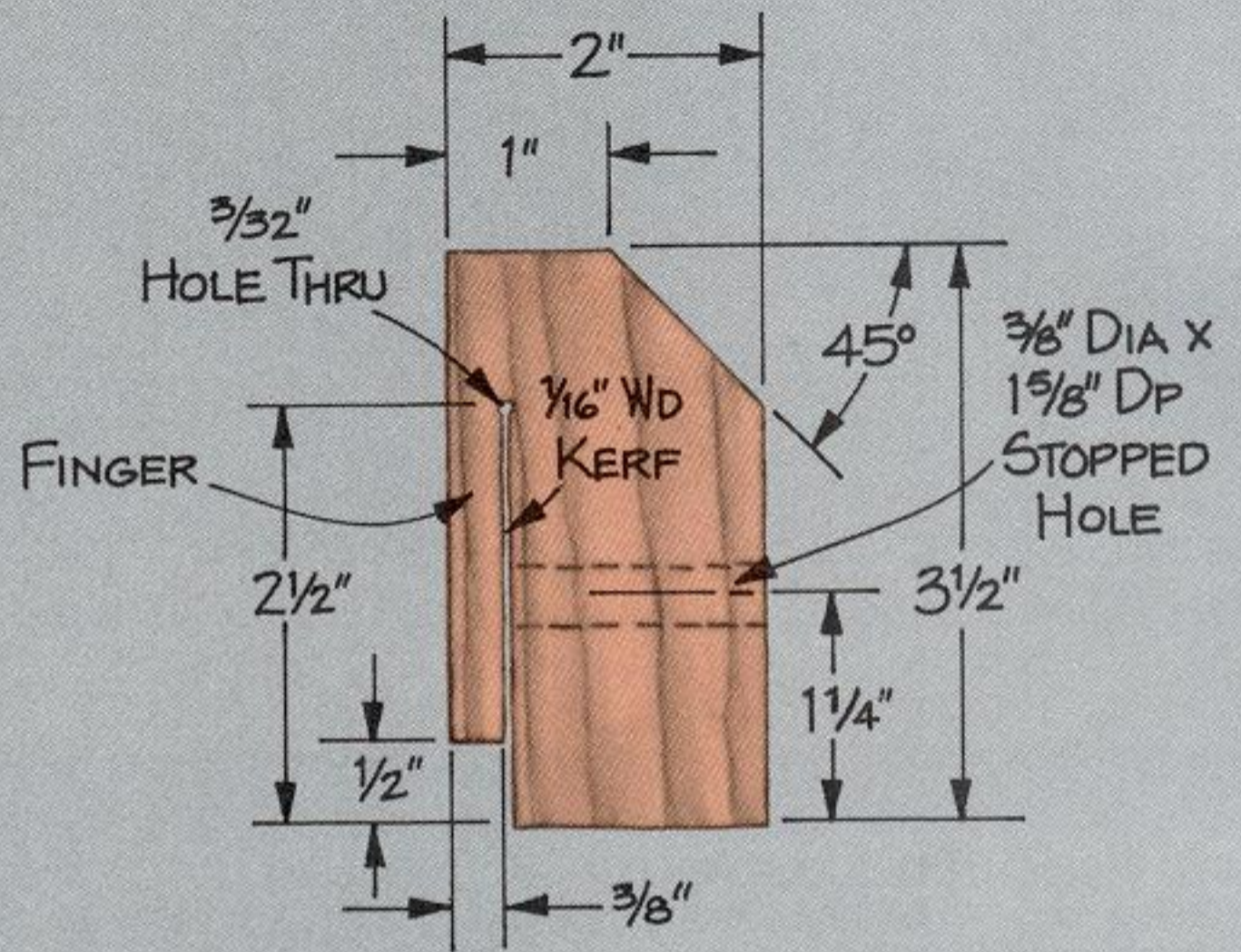

FENCE BRACE
LAYOUT

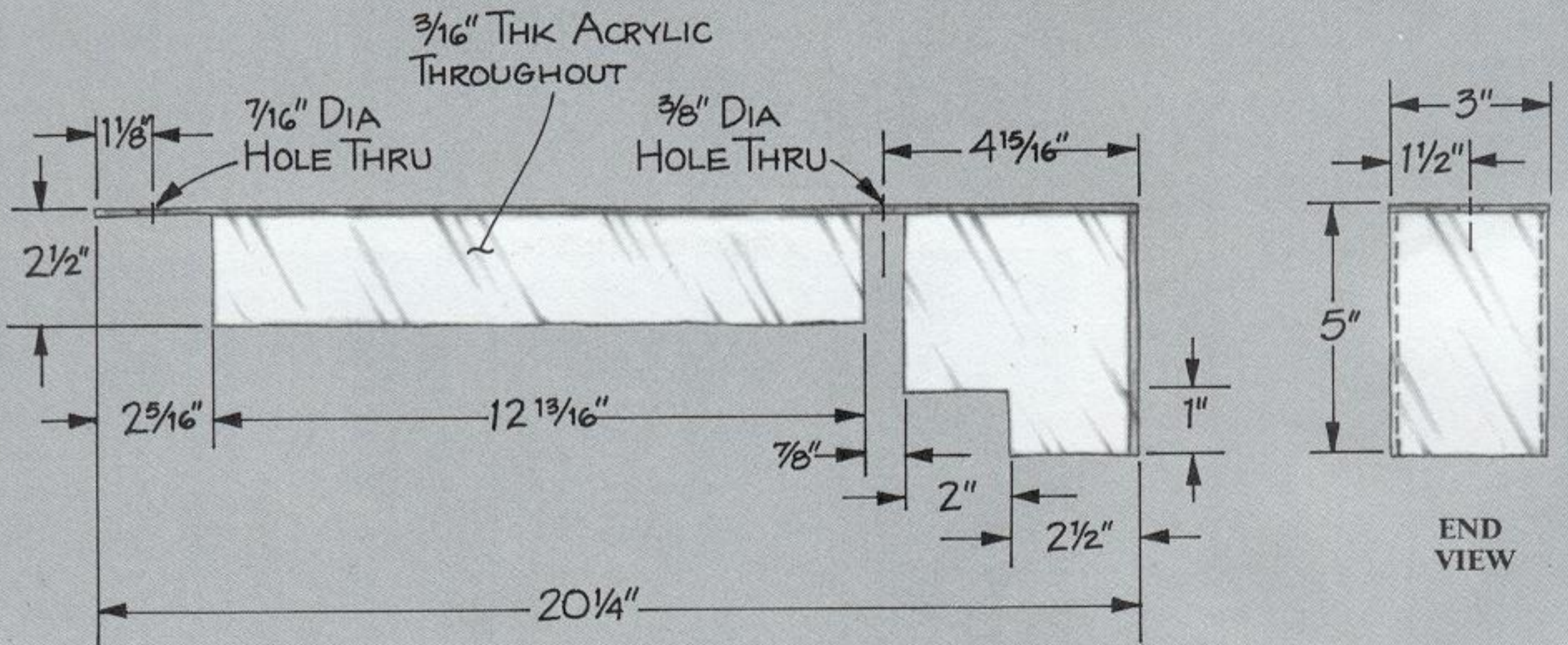

SIDE VIEW

END VIEW

GUARD

MAKING MITER CUTS

There is little difference between making a butt cut and making a miter cut. If you're making the cut on a table saw, set the miter gauge to the proper angle. If you're using a radial arm saw, set the arm. To make a cut of 30, 45, or 60 degrees, use a drafting triangle to set the miter gauge or the arm. To make a cut at some other angle, use a protractor and a sliding T-bevel.

The procedure is similar if you're cutting a bevel, but you must set the blade at the proper angle. Measure the angle between the blade and the table with a triangle or protractor — the degree markings on the saw are notoriously inaccurate.

Always cut a few test pieces with this setup *before* you cut good stock. Make at least two miter cuts, hold the parts together, and measure the angle between them. (SEE FIGURE 3-3.) Some woodworkers prefer to

make a miniature frame from test stock. Cut the required number of frame members to precisely the same length and miter the ends. Fit the pieces together. If there are no gaps in any of the miters, then the setup is adjusted to the proper angle.

In addition to cutting simple miters and bevels, you can also make *compound miters*, mitering *and* beveling a board at the same time. Compound miters are used to assemble moldings and sloping frames, in which the faces of the frame members rest at angles instead of presenting a flat face or edge. The angle or *slope* of the frame members determines the miter and bevel angles. Consult "Compound Miter Angles" on the facing page for the proper settings for both the miter gauge (or saw arm) and the saw blade. (SEE FIGURES 3-4 AND 3-5.)

3-3 To test a miter setup, cut two test pieces and hold the mitered ends together. Measure the angle between the pieces with a square or sliding T-bevel. If the angle is *smaller* than you hoped for and the square or protractor won't fit between the test pieces, *increase* the angle of the miter gauge. If the angle is *larger*, and there's a gap between the test pieces and the measuring device, then *decrease* the miter gauge angle.

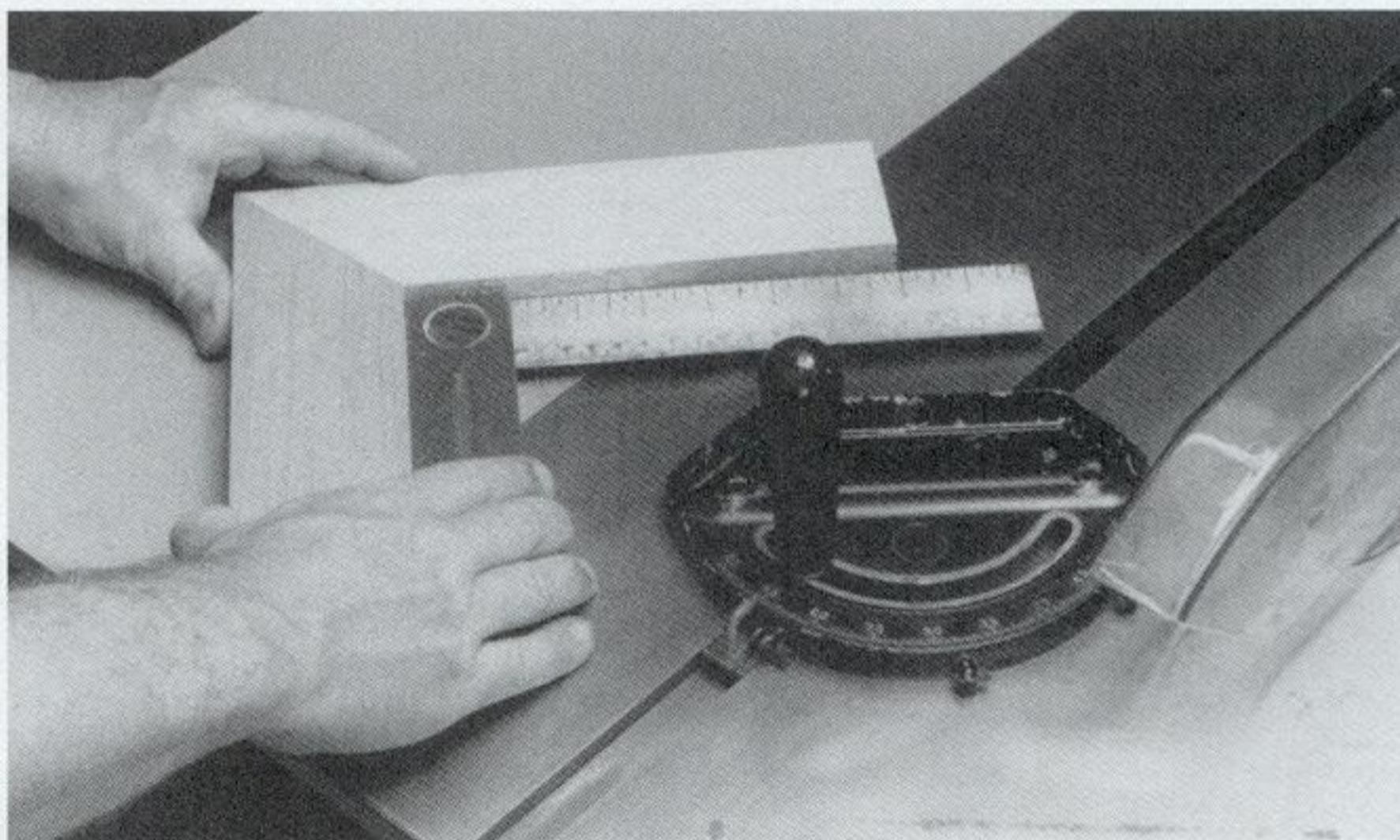

3-4 To cut a compound miter, set the miter gauge at an angle *and* tilt the saw blade. The gauge angle and the blade angle are determined by both the number of sides in the frame you want to make and the *slope* of its members.

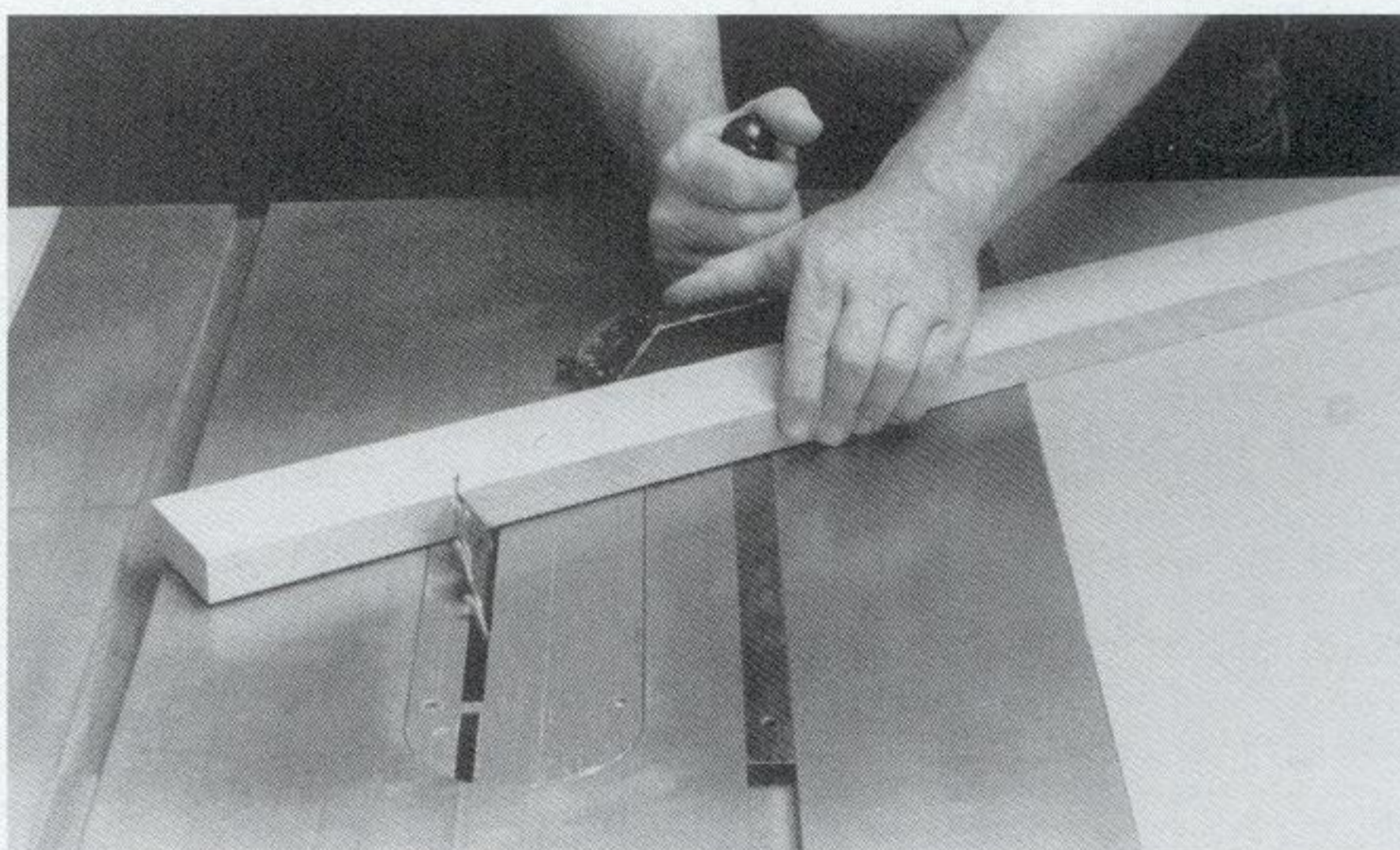

3-5 To check the setup, cut a test frame and assemble the members with masking tape. Measure the slope with a sliding T-bevel and a protractor. If the slope is *steeper* than you want, *decrease* the angle of the miter gauge. If it's *shallower*, *increase* the angle. Also inspect the joints. If they open on the *outside*, *increase* the tilt of the blade. If they open on the *inside*, *decrease* the tilt. Make these adjustments slowly, changing the miter gauge angle and the blade tilt no more than $\frac{1}{2}$ degree at a time. You may have to cut several test frames before the setup is adjusted properly.

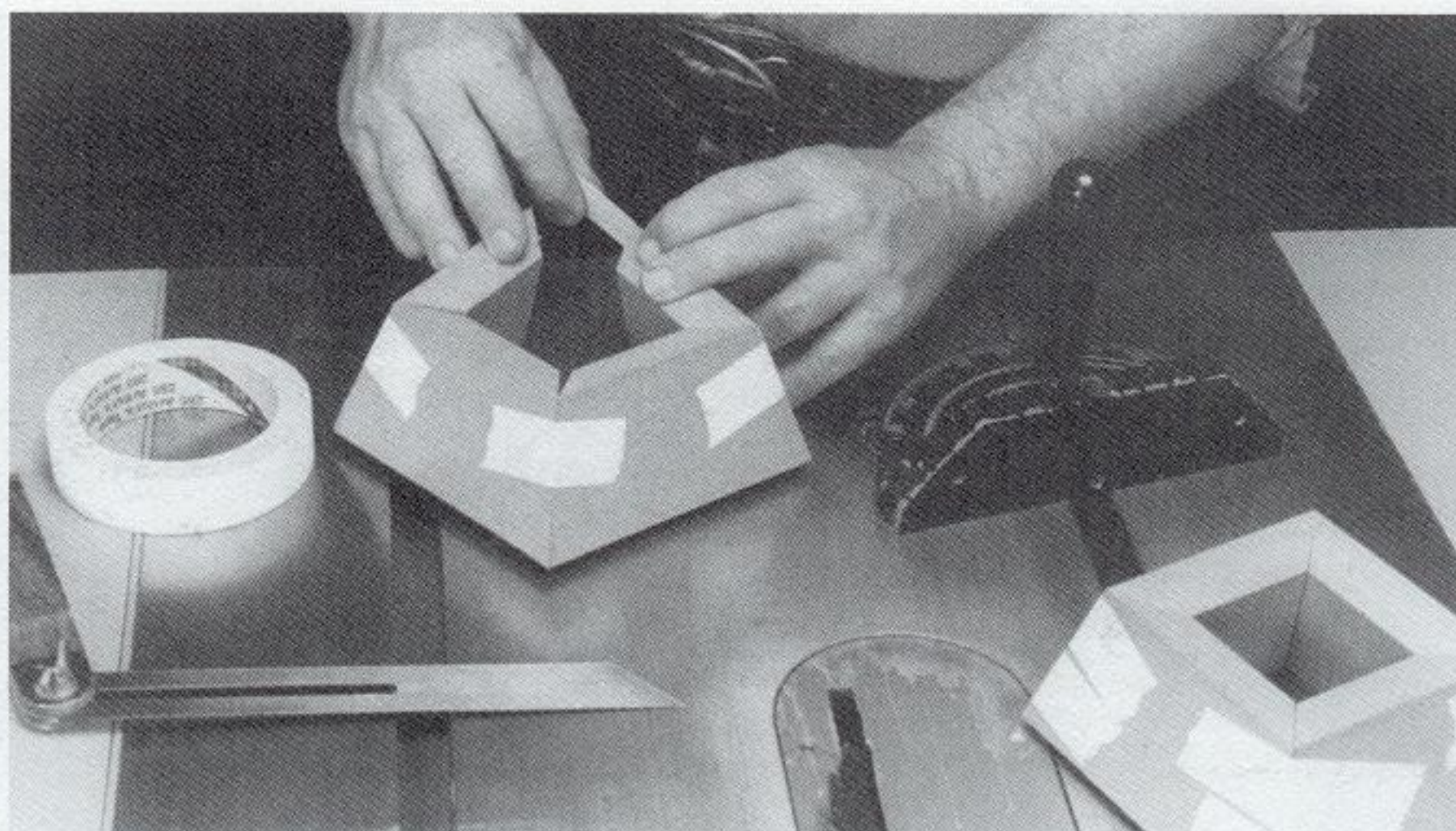

COMPOUND MITER ANGLES

FOUR SIDES			SIX SIDES		
SLOPE* OF FRAME	MITER GAUGE OR SAW ARM ANGLE†	SAW BLADE ANGLE	SLOPE* OF FRAME	MITER GAUGE OR SAW ARM ANGLE†	SAW BLADE ANGLE
85°	86°	44 $\frac{3}{4}$ °	85°	87 $\frac{1}{2}$ °	29 $\frac{3}{4}$ °
80°	82 $\frac{1}{4}$ °	44 $\frac{1}{4}$ °	80°	84 $\frac{3}{4}$ °	29 $\frac{1}{2}$ °
75°	78 $\frac{1}{4}$ °	43 $\frac{1}{2}$ °	75°	82 $\frac{1}{4}$ °	29°
70°	74 $\frac{1}{2}$ °	42 $\frac{1}{4}$ °	70°	79 $\frac{3}{4}$ °	28 $\frac{1}{4}$ °
65°	71°	40 $\frac{3}{4}$ °	65°	77 $\frac{1}{4}$ °	27 $\frac{1}{4}$ °
60°	67 $\frac{1}{2}$ °	39°	60°	75°	26°
55°	64 $\frac{1}{4}$ °	36 $\frac{3}{4}$ °	55°	72 $\frac{3}{4}$ °	24 $\frac{1}{2}$ °
50°	61°	34 $\frac{1}{2}$ °	50°	70 $\frac{3}{4}$ °	23°
45°	58 $\frac{1}{4}$ °	31 $\frac{3}{4}$ °	45°	68 $\frac{3}{4}$ °	21 $\frac{1}{4}$ °
40°	55 $\frac{1}{2}$ °	29°	40°	67°	19 $\frac{1}{4}$ °
35°	53 $\frac{1}{4}$ °	25 $\frac{3}{4}$ °	35°	65 $\frac{1}{2}$ °	17 $\frac{1}{4}$ °
30°	51°	22 $\frac{1}{2}$ °	30°	64°	15°
25°	49 $\frac{1}{4}$ °	19°	25°	62 $\frac{3}{4}$ °	12 $\frac{3}{4}$ °
20°	47 $\frac{3}{4}$ °	15 $\frac{1}{2}$ °	20°	61 $\frac{3}{4}$ °	10 $\frac{1}{4}$ °
15°	46 $\frac{1}{2}$ °	11 $\frac{3}{4}$ °	15°	61°	7 $\frac{3}{4}$ °
10°	45 $\frac{3}{4}$ °	7 $\frac{3}{4}$ °	10°	60 $\frac{1}{2}$ °	5 $\frac{1}{4}$ °
5°	45 $\frac{1}{4}$ °	4°	5°	60°	2 $\frac{1}{2}$ °
EIGHT SIDES					
85°	88°	22 $\frac{1}{2}$ °	35°	71 $\frac{1}{2}$ °	13°
80°	86°	22 $\frac{1}{4}$ °	30°	70 $\frac{1}{2}$ °	11 $\frac{1}{4}$ °
75°	84 $\frac{1}{4}$ °	21 $\frac{3}{4}$ °	25°	69 $\frac{1}{2}$ °	9 $\frac{1}{2}$ °
70°	82 $\frac{1}{4}$ °	21 $\frac{1}{4}$ °	20°	68 $\frac{3}{4}$ °	7 $\frac{3}{4}$ °
65°	80 $\frac{1}{2}$ °	20 $\frac{1}{2}$ °	15°	68 $\frac{1}{4}$ °	5 $\frac{3}{4}$ °
60°	78 $\frac{3}{4}$ °	19 $\frac{1}{2}$ °	10°	67 $\frac{3}{4}$ °	4°
55°	77°	18 $\frac{1}{2}$ °	5°	67 $\frac{1}{2}$ °	2°
50°	75 $\frac{1}{2}$ °	17 $\frac{1}{4}$ °			
45°	74°	16°			
40°	72 $\frac{3}{4}$ °	14 $\frac{1}{2}$ °			

*The slope of the stock's face, as measured from horizontal.

†For the proper saw arm setting, subtract the angle shown on the chart from 90°.

MITER JIG

If you make many miter cuts, you may tire of constantly readjusting your miter gauge to the proper angle. Instead, you can set this jig to any angle between 70 and 30 degrees (approximately), then leave it so it's always ready to go. And if you regularly cut several miter angles, build several jigs and set each to the appropriate angle.

The sliding table is made of medium-density fiberboard (MDF), with two acrylic plastic runners that ride in the miter gauge slots, guiding the jig's table back and forth across the table saw. Two adjustable fences, one for making left-facing miters and the other for right-facing miters, back up the stock as you cut it.

1 Rout the curved slots in the adjustable fences with a router and a *Circle-Cutting Jig*. This simple jig is a piece of $\frac{1}{4}$ -inch plywood cut to fit the base of your router. Drill a $\frac{1}{4}$ -inch-diameter pivot hole in the plywood, $9\frac{1}{4}$ inches from the router bit. Rout the slot in several passes, cutting $\frac{1}{8}$ inch to $\frac{1}{4}$ inch deeper with each pass.

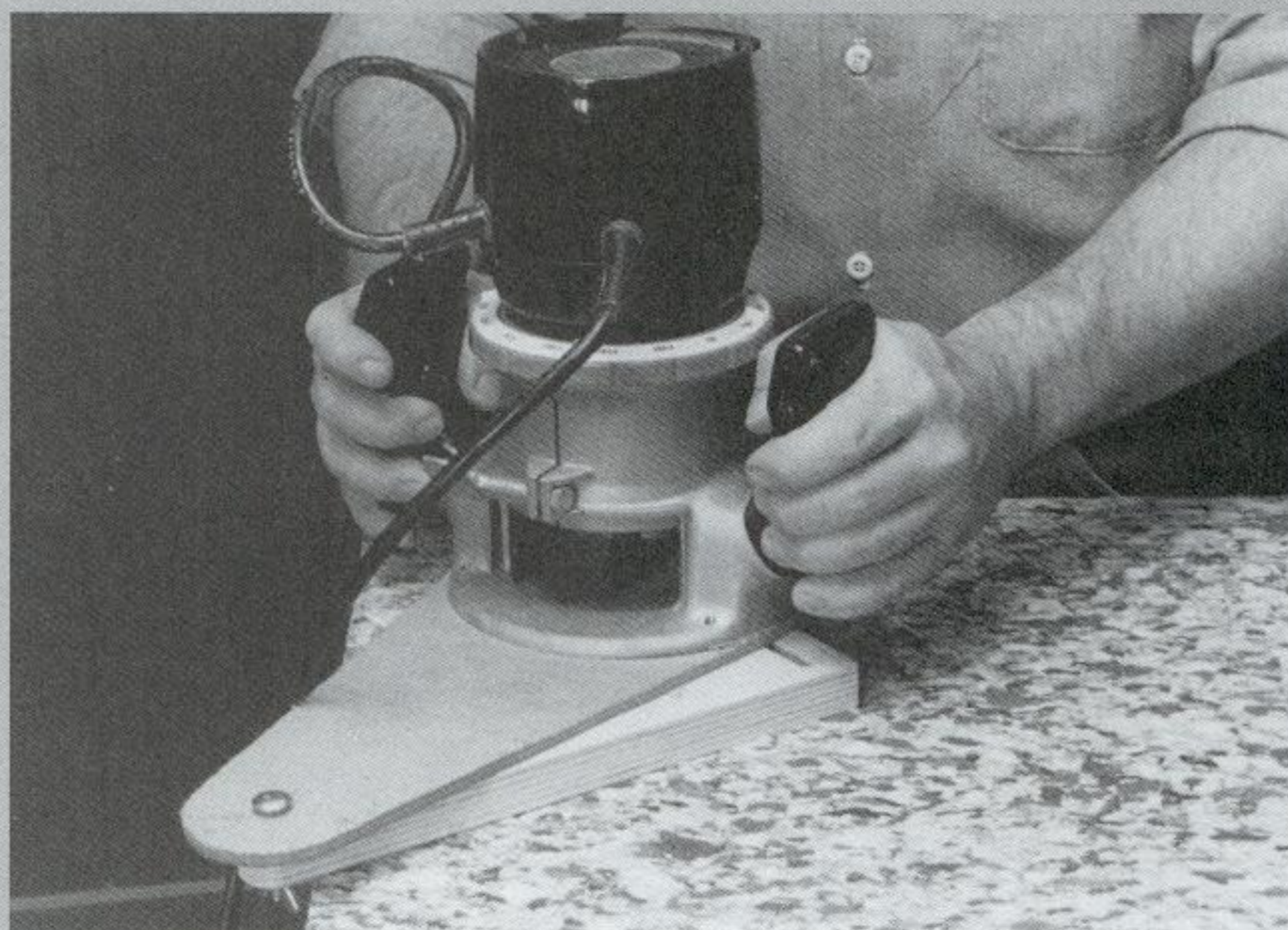

2 Place the jig on the table saw so the runners fit in the miter gauge slots, and cut a saw kerf in the sliding table. Do *not* cut all the way through the table. Stop the kerf just past the fences. Turn off the saw and use a drafting triangle, square, protractor, or sliding T-bevel to adjust the fences. Afterwards, make several test cuts with each fence to ensure it is set properly.

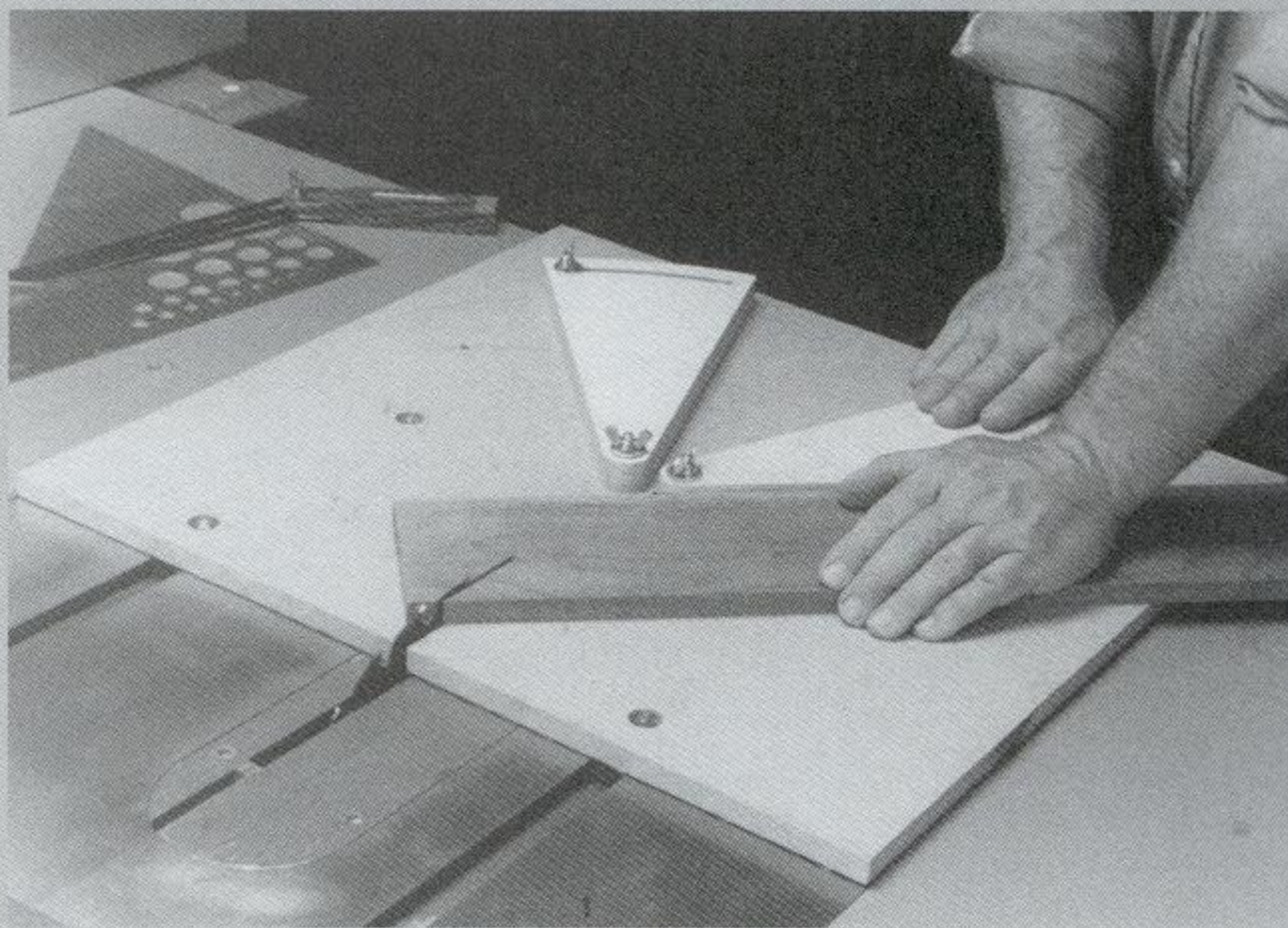

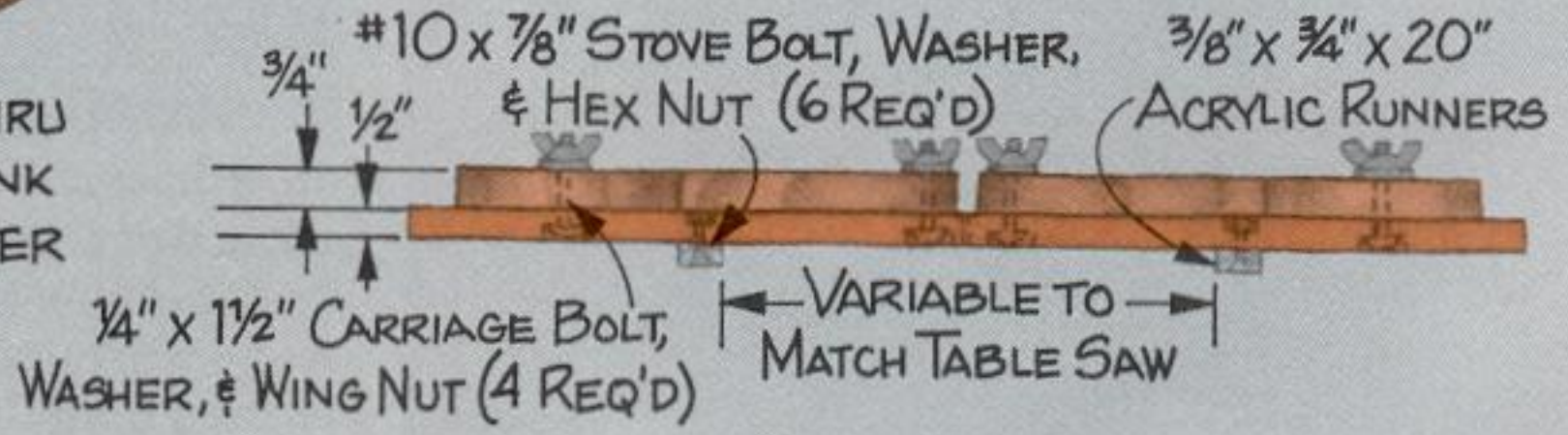
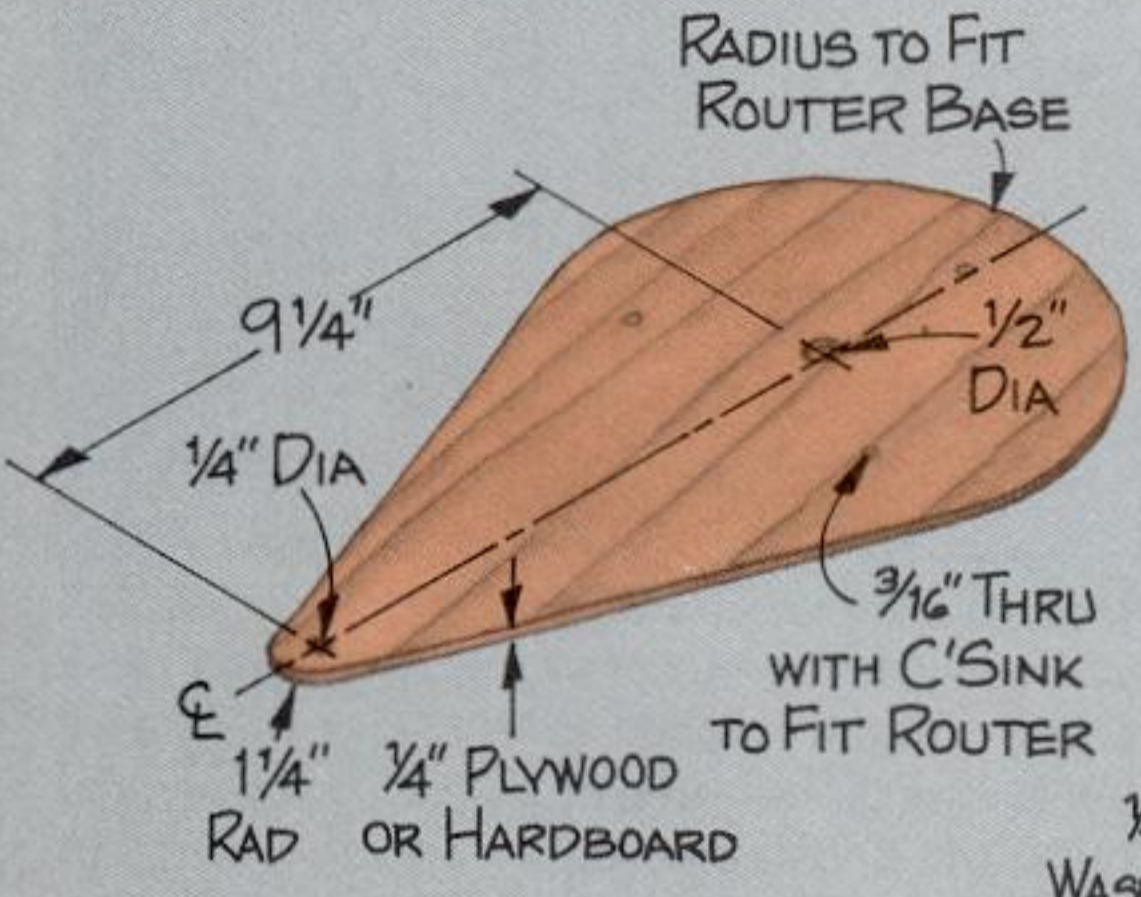
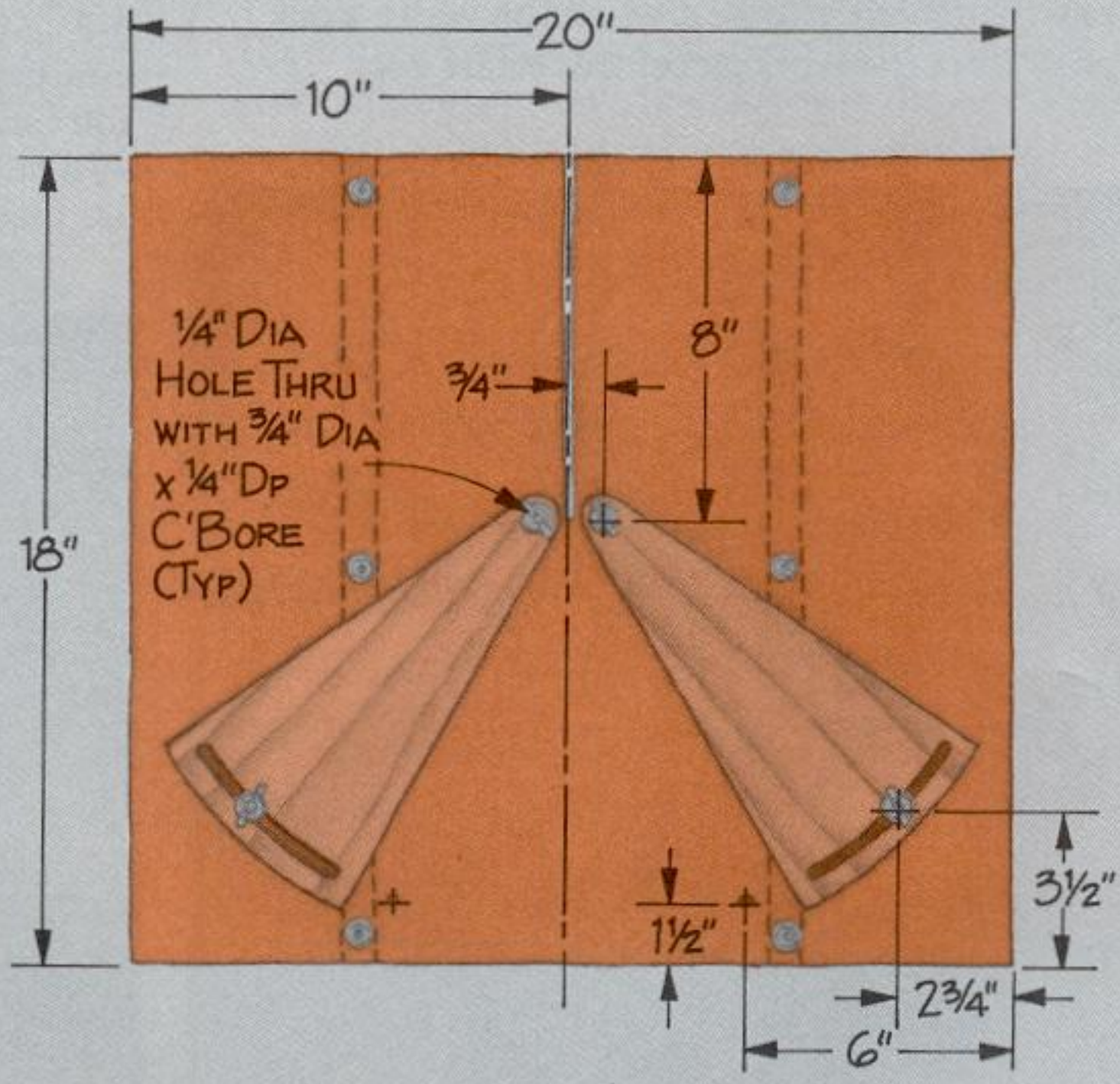
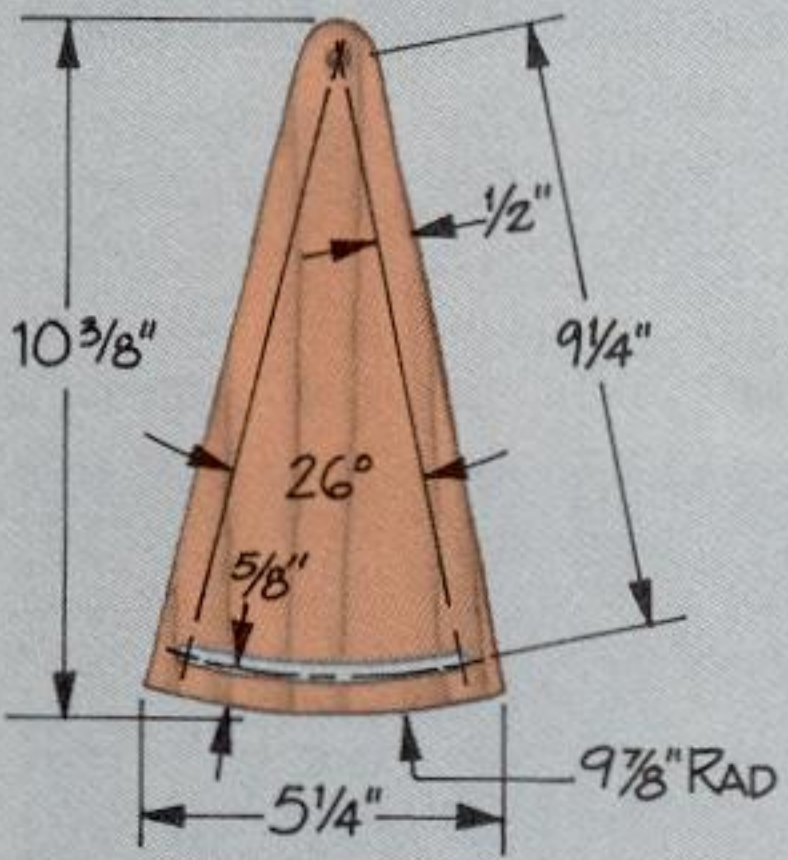
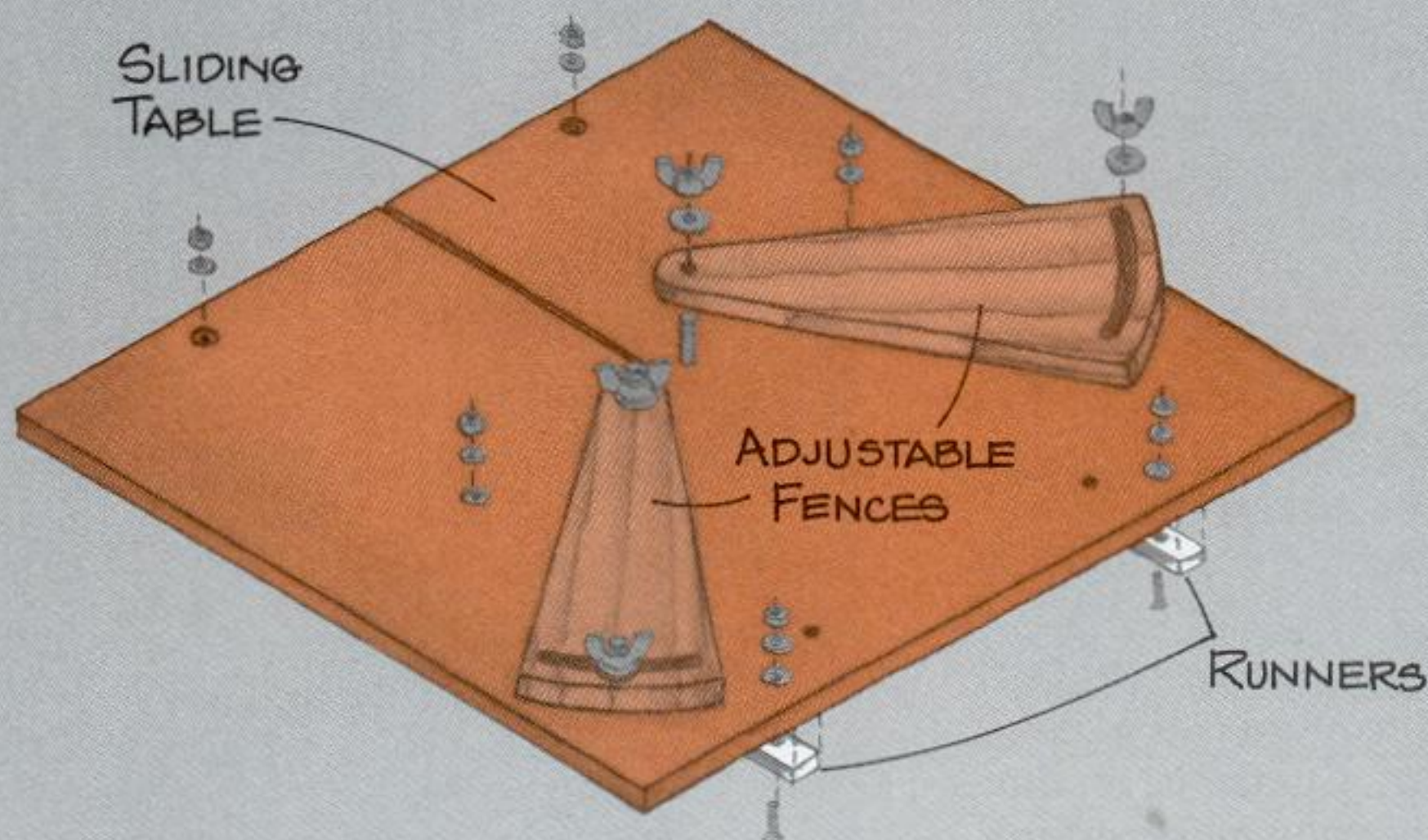

MAKING RABBET CUTS

You can make a rabbet with either a table-mounted router and a straight bit, or a table saw and a dado cutter. For either setup, use a fence to guide the work. Adjust the width of the rabbet by changing the position of the fence relative to the bit or cutter. Adjust the depth by changing the height of the bit or cutter above the table.

Cut a rabbet in a test piece, feeding the wood past the bit or cutter. (Remember to feed the wood *against* the rotation of the cutting tool.) Measure the width and depth of the rabbet and, if necessary, adjust the position of the fence or the height of the cutter. Then cut the good stock. (SEE FIGURES 3-6 AND 3-7.)

You can also use a table saw and an ordinary saw blade to cut a rabbet, but this requires two passes and — almost always — two setups. Cut the larger dimension first, then the smaller. Since you must perform this operation without the saw guard, this sequence will leave less blade exposed when the waste stock falls away from the workpiece. (SEE FIGURE 3-8.)

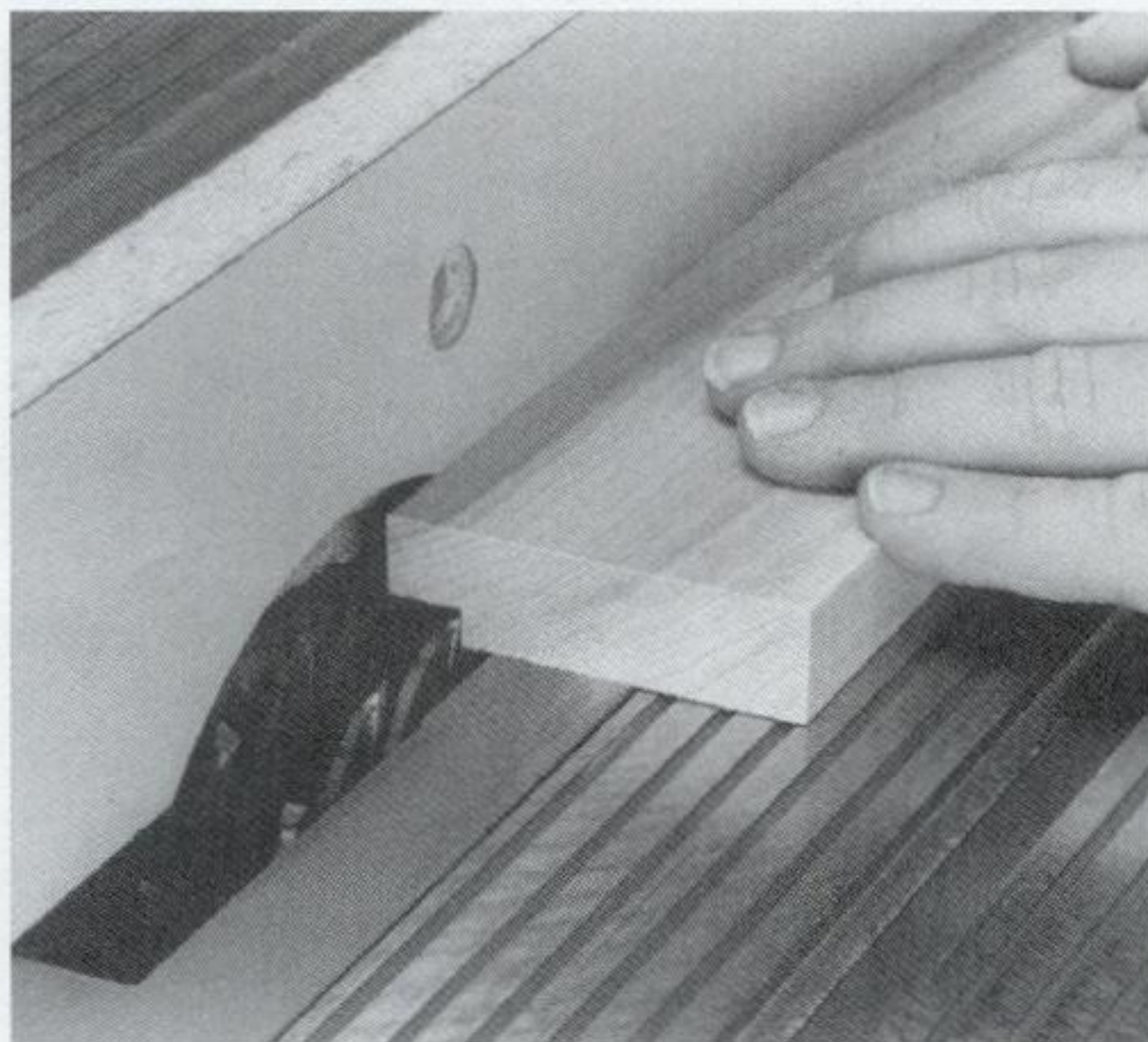

3-6 To cut a rabbet, feed the board past the bit or cutter, keeping it pressed against both the table and the fence. Note that the fence is faced with a board, and this board has a cutout the same diameter as the cutter. The board protects both the fence *and* you. It keeps the cutter from biting into the metal fence, and the cutout surrounds the unused portion of the cutter. *Never* cut a rabbet with part of the bit or cutter exposed.

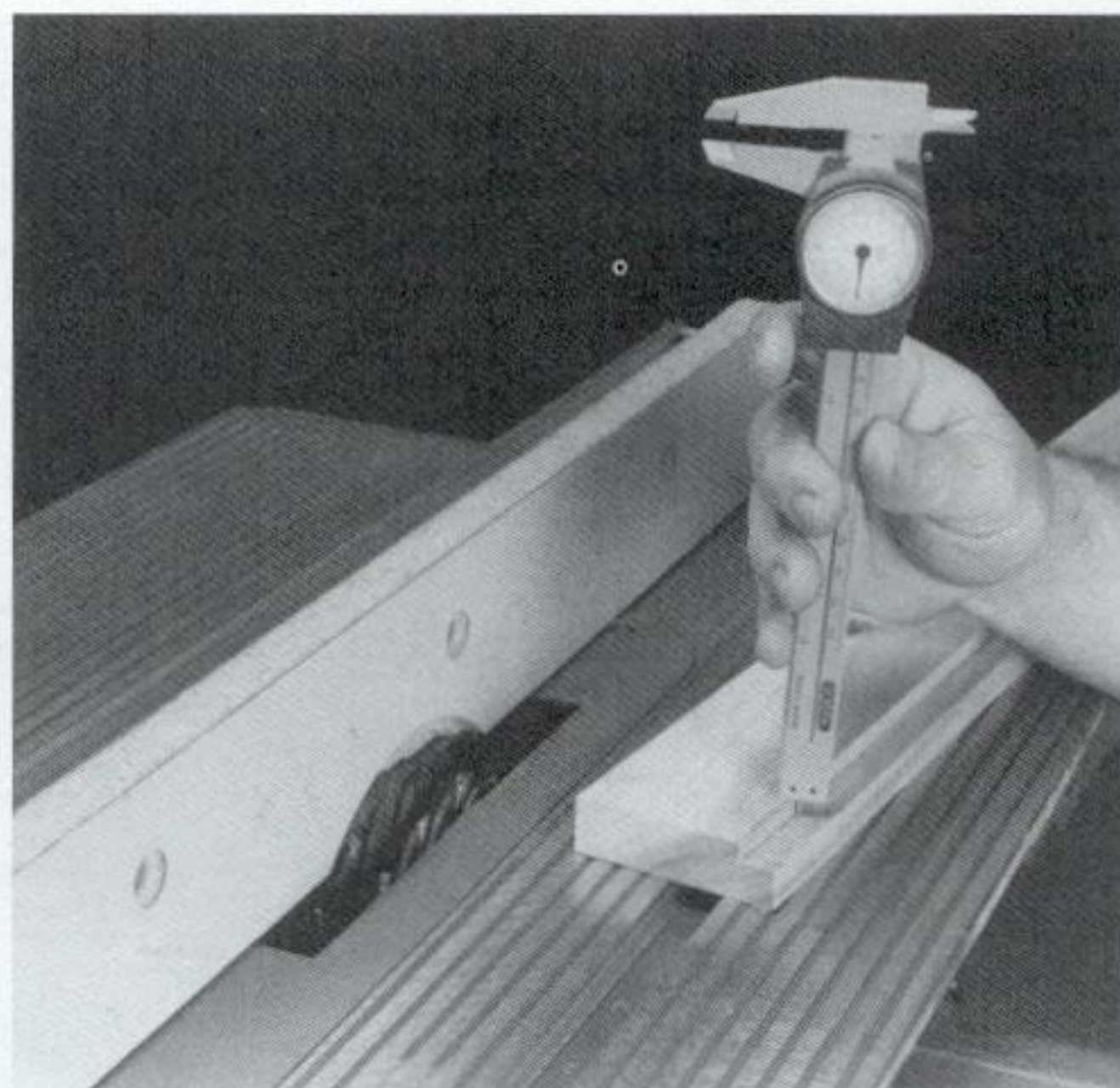

3-7 After cutting a test rabbet, measure the width and the depth. You can use a small rule for this, or — if you want to be more precise — use the depth gauge on your calipers.

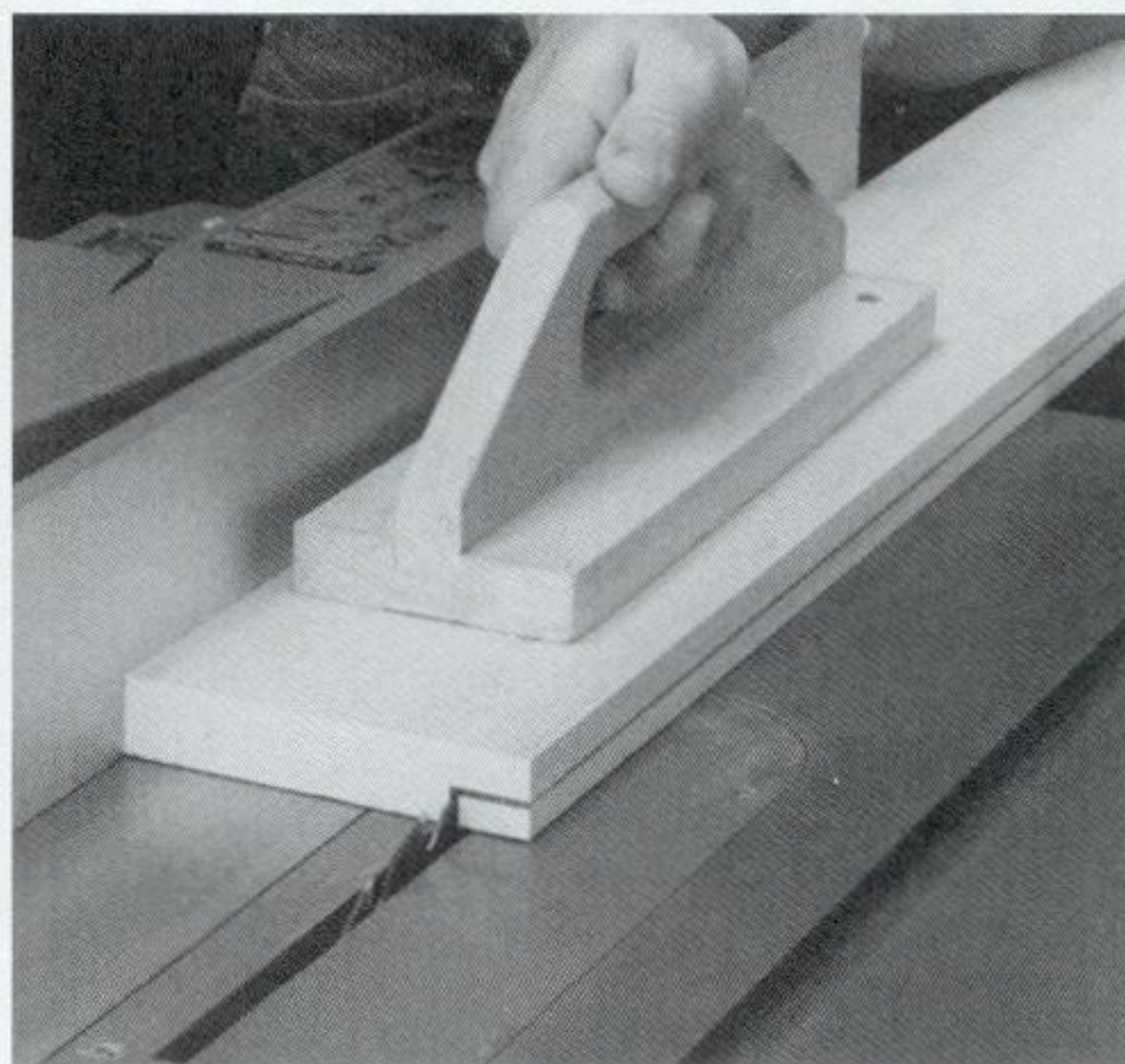

3-8 When cutting a rabbet with an ordinary saw blade, you must make two passes. On the second pass, position the workpiece so the waste will be on the side of the blade farthest from the fence. If you make the cut with the waste between the fence and the blade, the waste will kick back.



FOR BEST RESULTS

After cutting a rabbet with a dado cutter or a saw blade, inspect the inside corner between the side and the bottom. These cutting tools sometimes leave a little waste or “tang” in the corner. You can quickly remove this with a scraper, chisel, or bullnose plane.

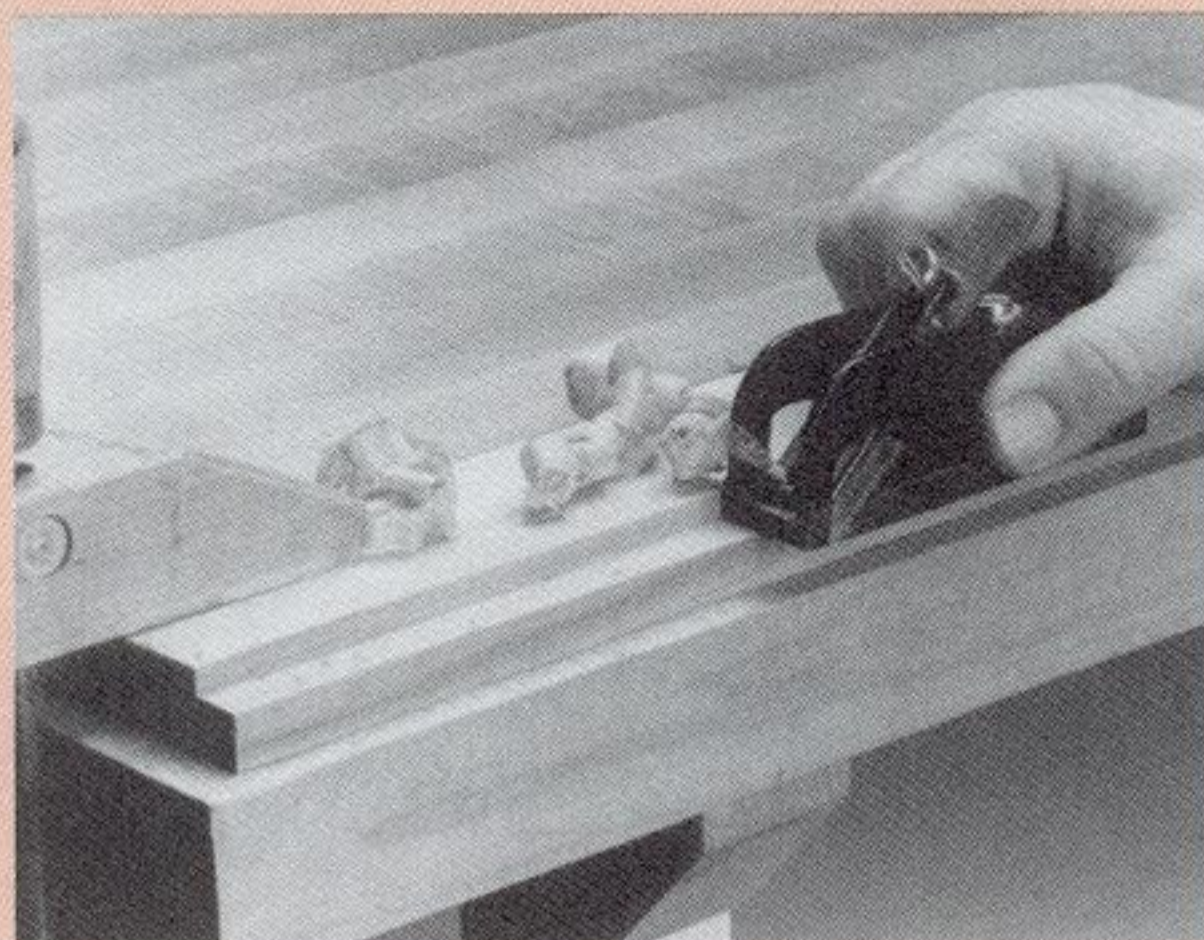

MAKING DADO CUTS

Like a rabbet, a dado can be made with either a table-mounted router and a straight bit, or a table saw and a dado cutter. The adjustments, however, are not quite the same. Adjust the width of the dado by changing the width of the cutter or the diameter of the bit; adjust the depth by raising or lowering the bit or cutter. Finally, position the dado by changing the position of the workpiece relative to the cutter.

There are several ways to guide the workpiece. If you're making a groove (cutting *with* the wood grain), use a fence to guide the workpiece over the bit or cutter. If you're making a dado (cutting *across* the grain), use a miter gauge. If the workpiece is too large to guide easily with a miter gauge, clamp a straightedge to the workpiece and use it to guide a portable router. (SEE FIGURE 3-9.)

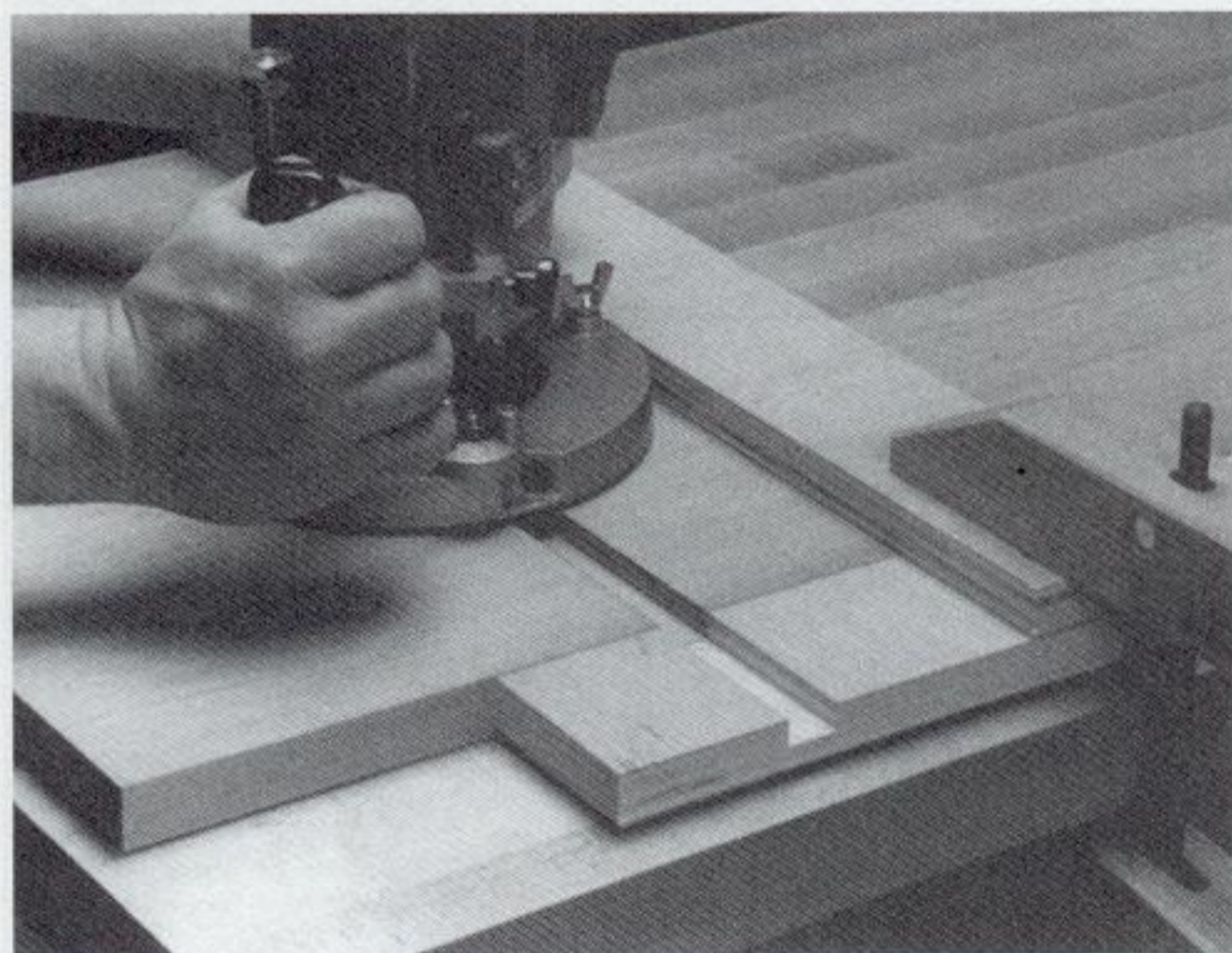

3-9 Use a portable router to make a dado or a rabbet if the board is too large to cut on a table saw or a table-mounted router. Clamp a straightedge to the workpiece to guide the router. Here, a shopmade T-square automatically aligns the straightedge at 90 degrees to the edge of the board.

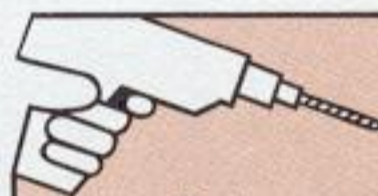

TRY THIS TRICK

In a pinch, you can cut a dado with an ordinary saw blade and some hand tools. Saw the sides of the dado to the proper depth and remove most of the waste with a chisel. Then clean up the bottom of the dado with a router plane.

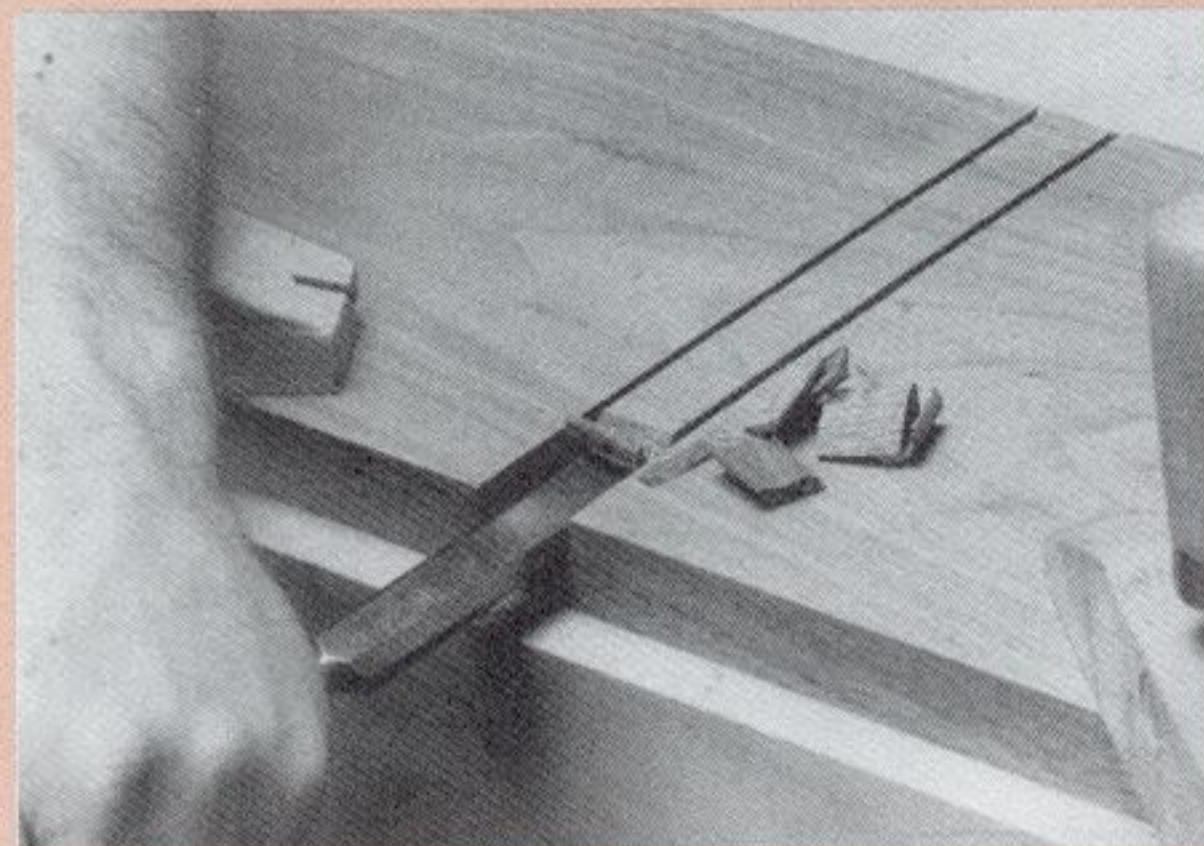

USING A ROUTER PLANE

Whether you prefer to cut joints by hand or by machine, one of the most useful joinery tools is the *router plane*. This simple hand tool cuts the *bottom* of a rabbet, dado, groove, or mortise to a uniform

depth. It will also cut the cheeks of a lap joint or a tenon. Use it to true up these joints or to remove a thin layer of stock to get a perfect fit.

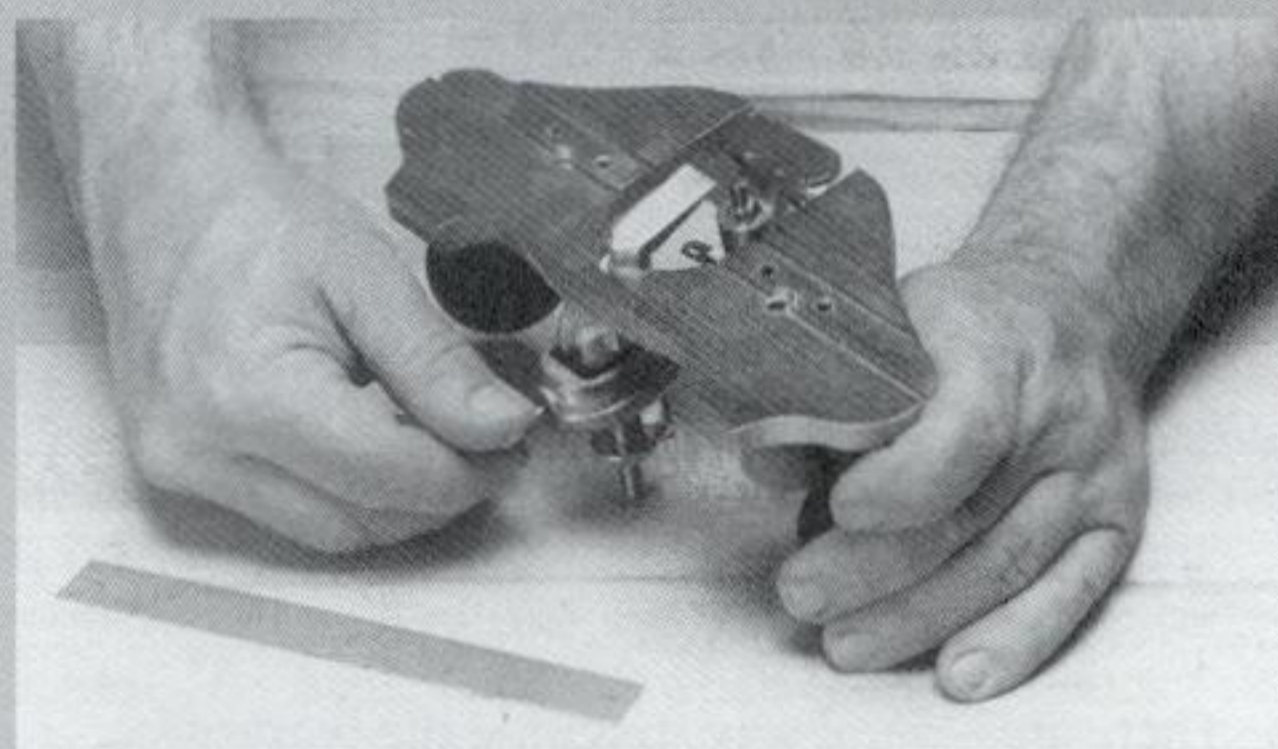

1 To use a router plane, first adjust the depth of cut. Raise or lower the L-shaped plane iron so it protrudes the proper distance below the plane base.



2 Place the plane on the workpiece so the base rests on the surface and the plane iron hangs down into the cut. Then push the plane forward, shaving the bottom. Remove just a little bit of stock at a time, no more than $\frac{1}{32}$ inch.

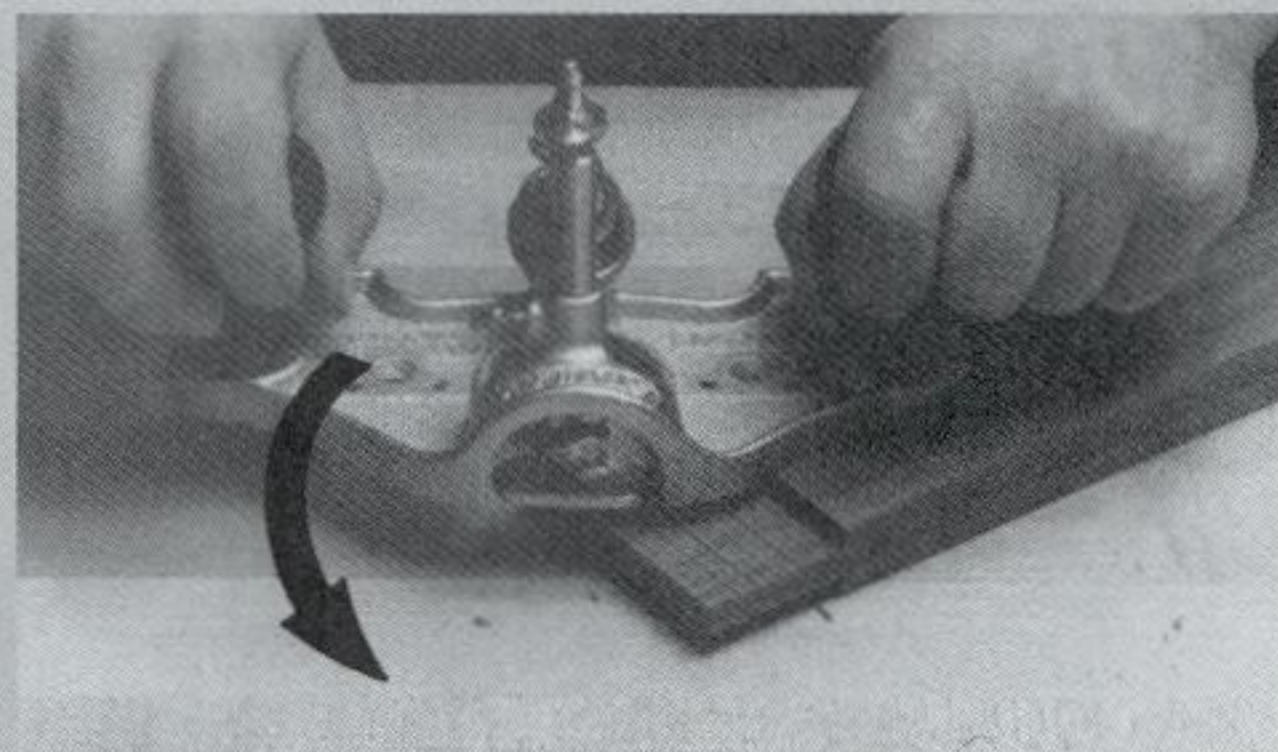

3 When cutting wide areas, such as the cheeks of a tenon, hold the plane so one part of the base rests on the stock's surface, and the other overhangs the area to be cut. Press down firmly on the side that sits on solid stock. Cut with a sweeping motion, pivoting the plane so the iron travels in an arc.

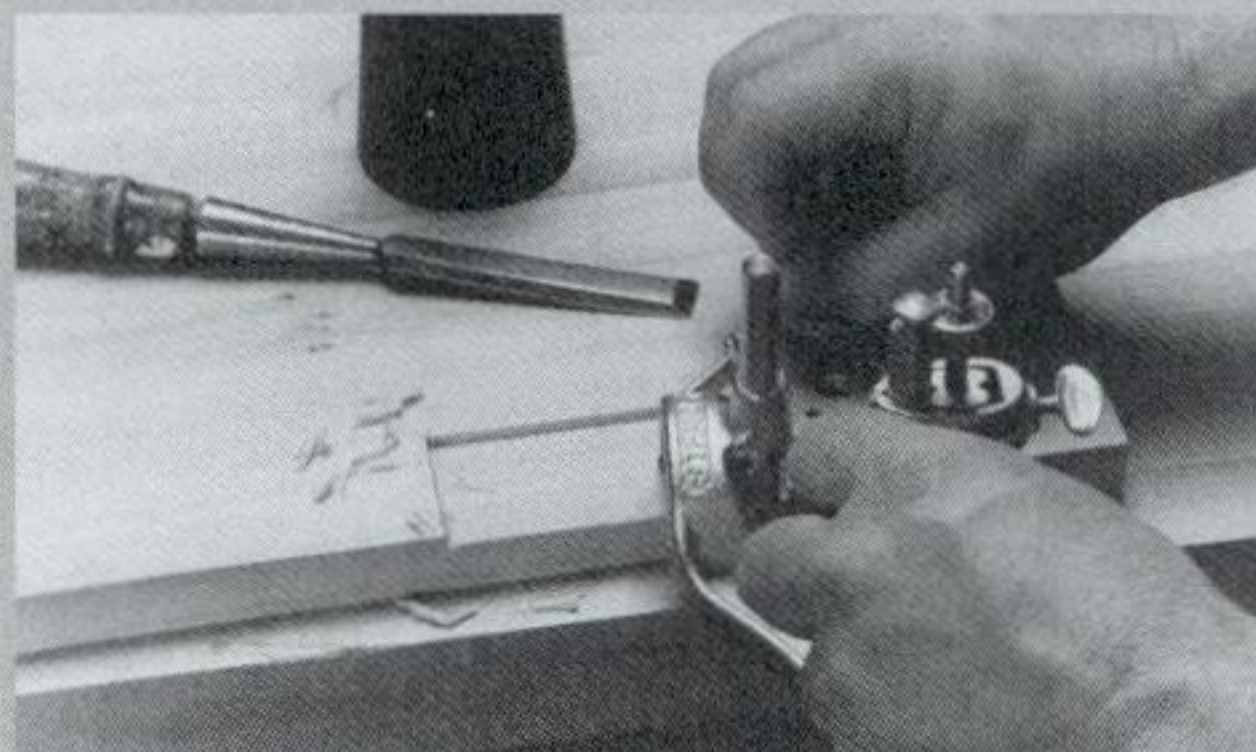

4 You can also use a router plane to cut the bottom of a mortise, notch, or dovetail, or any joint where a uniform depth is essential. Here, the plane is used to shave the bottom of a hinge mortise.

MAKING HOLES

While most basic joinery cuts are made with a saw or a router, holes must be bored with a drill and drill bits. Most woodworkers prefer to use *piloted* bits for joinery work. (SEE FIGURE 3-10.) The pilot is a small point on the cutting end of the bit which helps to position the hole accurately.

Before drilling a hole, check the diameter, angle, and position of the bit. The size of the bit will determine the diameter of the hole. The angle of the bit (in

relation to the work) determines the hole angle. (SEE FIGURES 3-11 AND 3-12.) To position the bit, simply move the work or the drill until the pilot of the bit is directly over the mark for the hole.

Drill holes at a slow speed, no more than 1,000 revolutions per minute (RPM). If the hole is over 1 inch in diameter, reduce this maximum speed to about 600 RPM. If the bit revolves too fast, the friction may cause the bit to heat up and burn the wood.

3-10 Three types of piloted drill bits are commonly used for joinery. A *spade bit* (1) is a good multipurpose wood bit. It's inexpensive and easy to sharpen, and it bores holes very quickly. However, it may wander, particularly when drilling deep holes. The *brad point bit* (2) drills more slowly and is more difficult to maintain, but it's more accurate. A *Forstner bit* (3) bores holes with flat bottoms and smooth sides. However, of the three bits shown, it cuts slowest and is most difficult to sharpen. And because it does not clear wood chips as well as other bits, it's not a good choice for deep holes. **Note:** Not all Forstner bits have pilots.

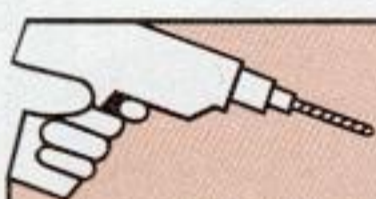
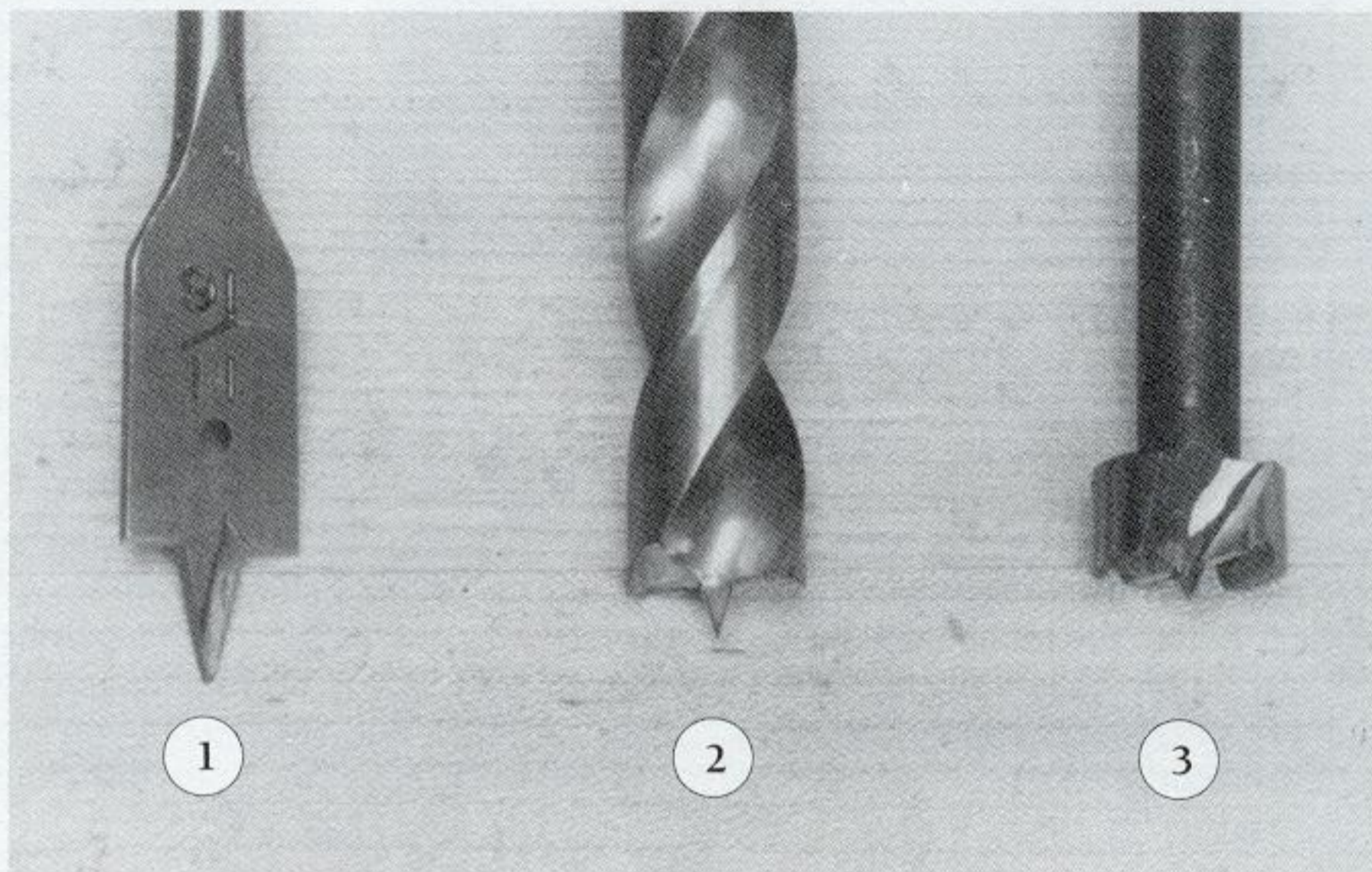

FOR BEST RESULTS

Drill bits often bore clean entrance holes but tear the wood grain when they exit a board. You can prevent much, but not all, of this tear-out by backing up the board with a scrap. A better method is to drill

the hole until just the pilot of the bit exits the board, then turn the board over. Using the pin-sized pilot hole to position the bit, finish the hole by drilling through from the other side.

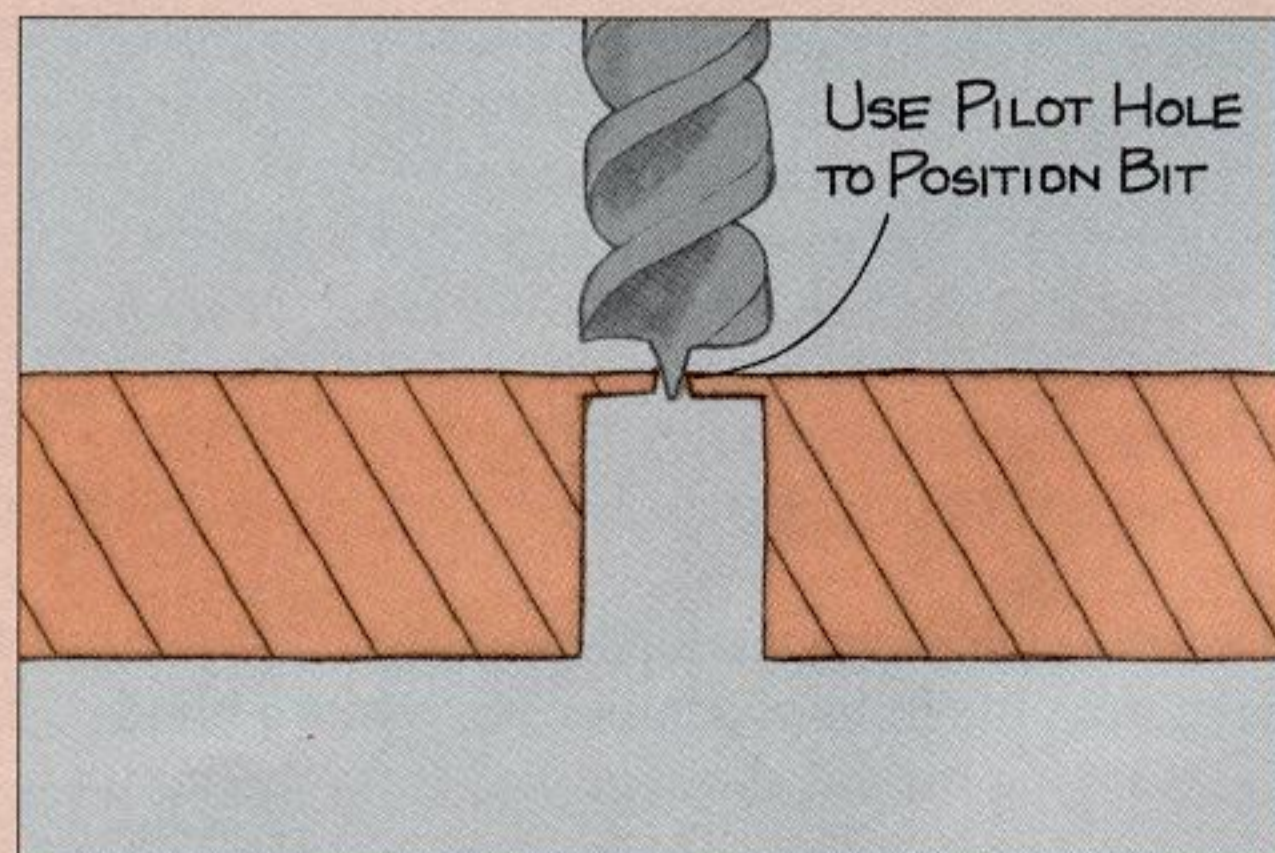
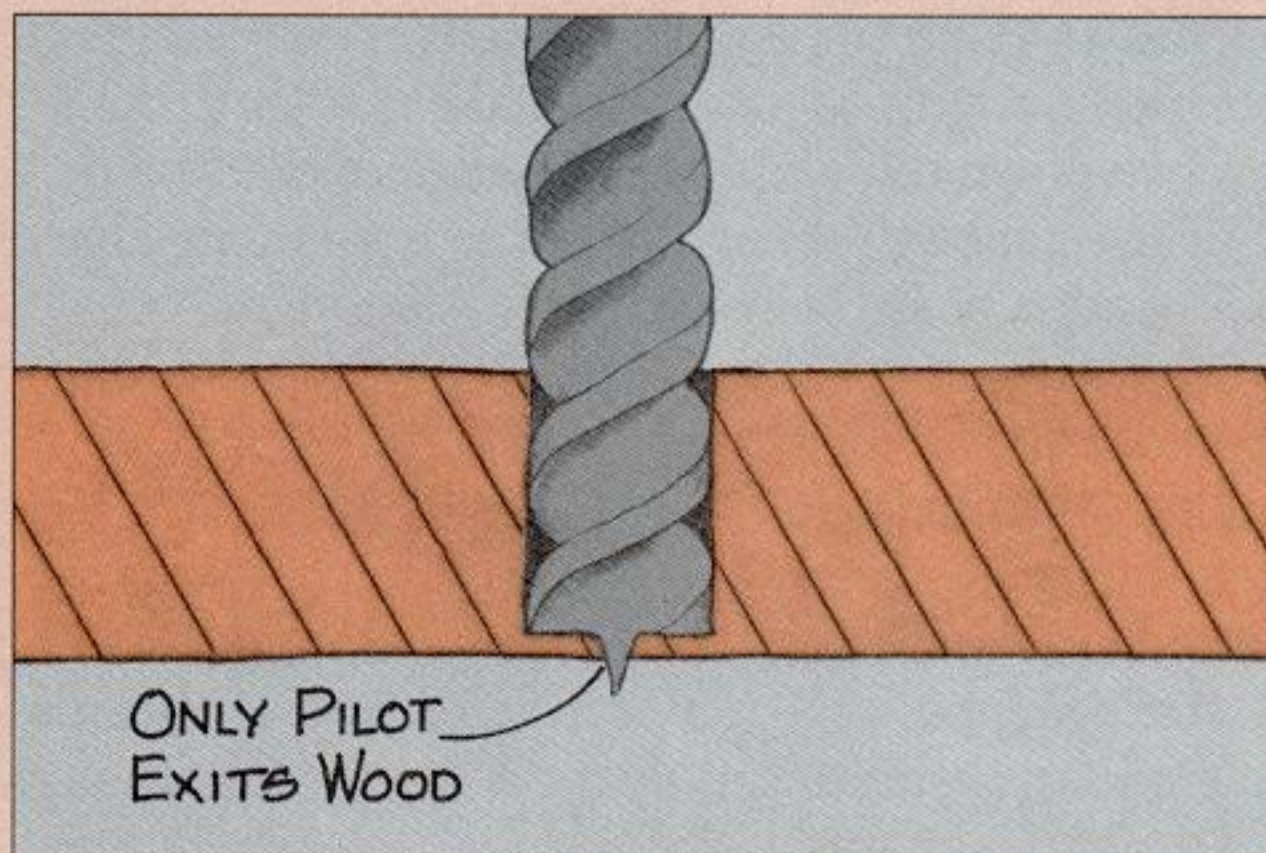

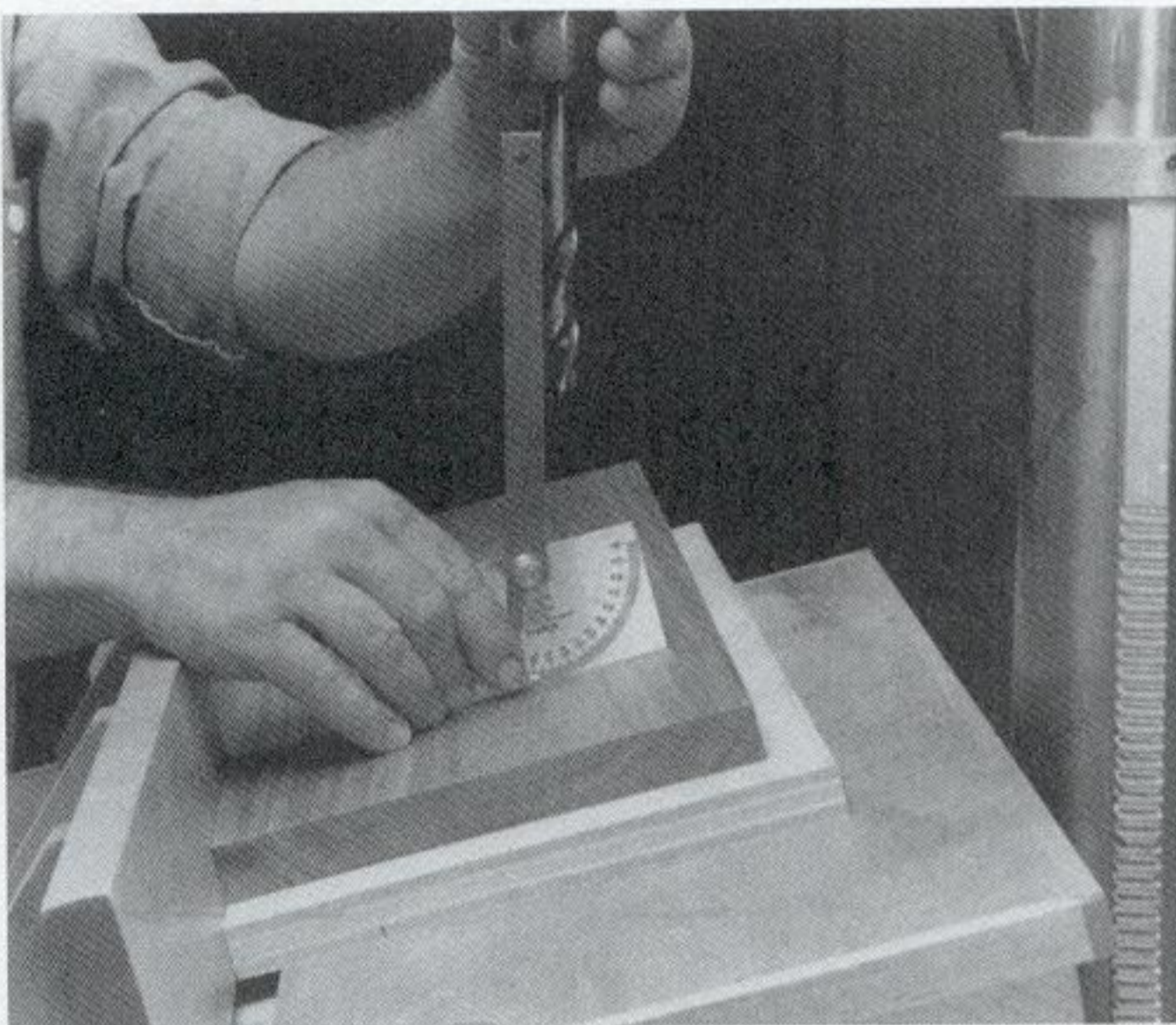

3-11 When drilling holes with a drill press, check the angle with a small square or a protractor. To adjust the angle, tilt the table. **Note:** Drill bits, like saw blades, may suffer from run-out. However, unlike blades, wobbly bits should be discarded. Rotate the bit at least one full revolution when you check the drill angle. If there's any visible run-out, use another bit.

SIMPLE VARIATIONS

It takes at least two cuts to make a woodworking joint — one or more cuts in each of the adjoining boards. For example, to fit the end of a shelf to a dado in the side of a cupboard, you must cut a dado in the side board and trim the shelf board to fit with a butt cut.

There are dozens of ways to join two boards with a few simple cuts. Here are several examples and suggestions on how you might use them (see “Examples of Simple Joinery” on the facing page):

- **Rabbet and Dado** — If the dado in a cupboard side is smaller than the thickness of a shelf, you can cut a rabbet in the shelf end to fit the dado. **Note:** Sometimes the rabbeted end of a board is referred to as a *bare-faced tongue*, especially when it fits in a dado or groove.

- **Blind Dado** — If you don't want the dado joint to be seen from the front of a cupboard, make a blind dado, stopping the cut about $\frac{1}{2}$ inch from the front edge of the cupboard side. Make a corner notch in the shelf to fit the blind end of the dado.

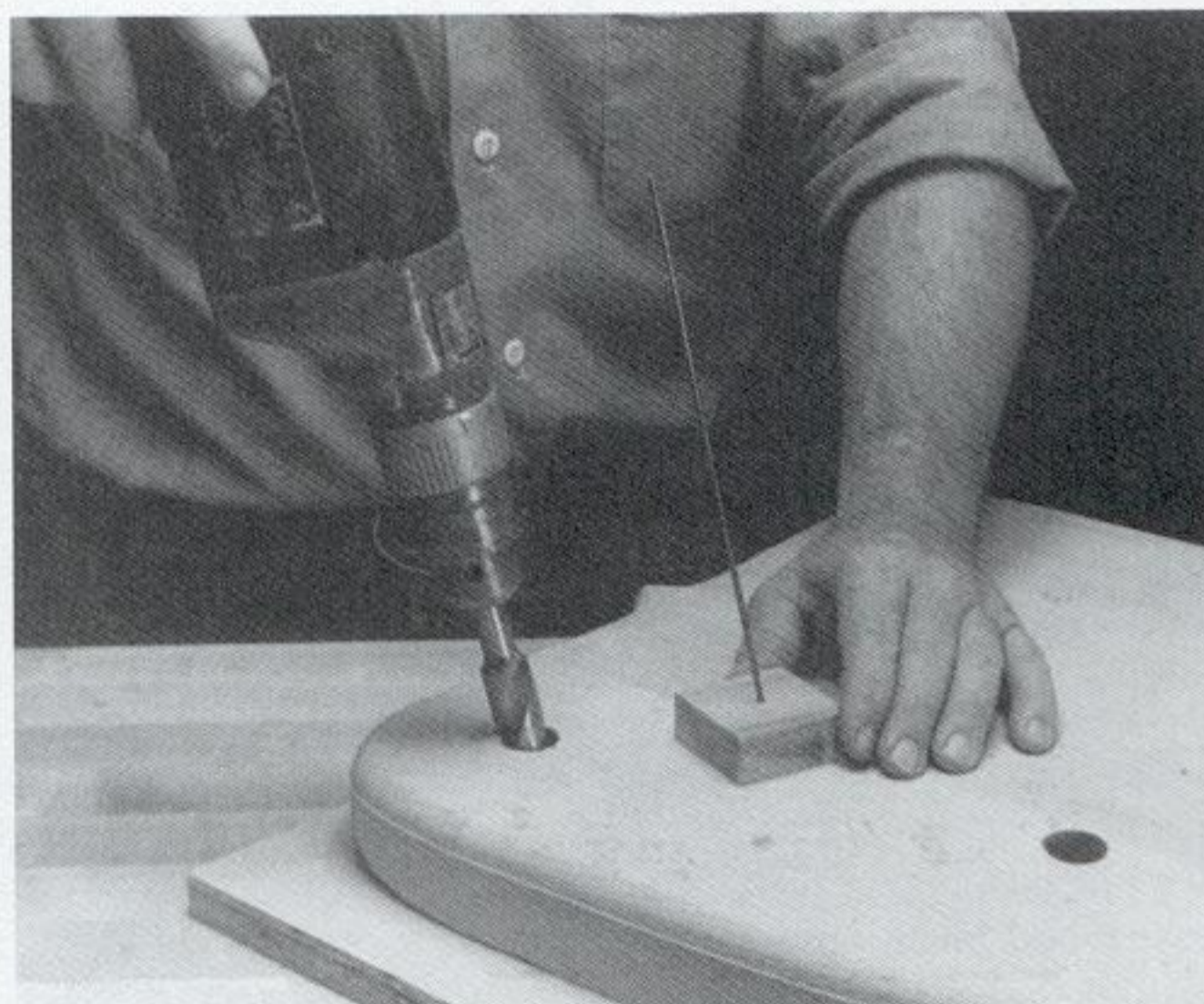

3-12 When drilling angled holes with a hand-held drill, make a guide by mounting a 6-inch length of coat hanger wire in a small scrap of wood. Bend the wire to the angle you want to drill, and place it close to the hole location. Drill the hole, sighting along both the wire and the bit to keep them parallel. You can buy jigs that hold a portable drill at a precise angle, but you'll be surprised at how accurate this simple method can be.

- **Lap** — You can join two members of a frame by cutting a rabbet in the end of each board and lapping the rabbets. This is called a *corner lap*. If you cut a rabbet in one board and a dado in the other, then lap the joints, it's an *end lap*. And if you lap two dado joints, it's a *cross lap*.

- **Tongue and Groove** — Tabletops, cupboard backs, and flooring are often fitted together with tongue-and-groove joints. To make this joint, cut a groove down the middle of the edge of one board. Cut two rabbets — one in each arris — in an edge of the second board. This will form the tongue.

- **Scarf** — One of the easiest ways to make long boards out of short ones is with a scarf joint. Cut miters in the adjoining ends of the boards, then lap the miters so the faces and edges of both boards are flush and parallel.

- **Edge Joint** — If you need to make wide boards out of narrow ones, simply rip and joint the adjoining edges of the boards so they are perfectly straight and square. Butt them together so the faces are flush.

EXAMPLES OF SIMPLE JOINERY

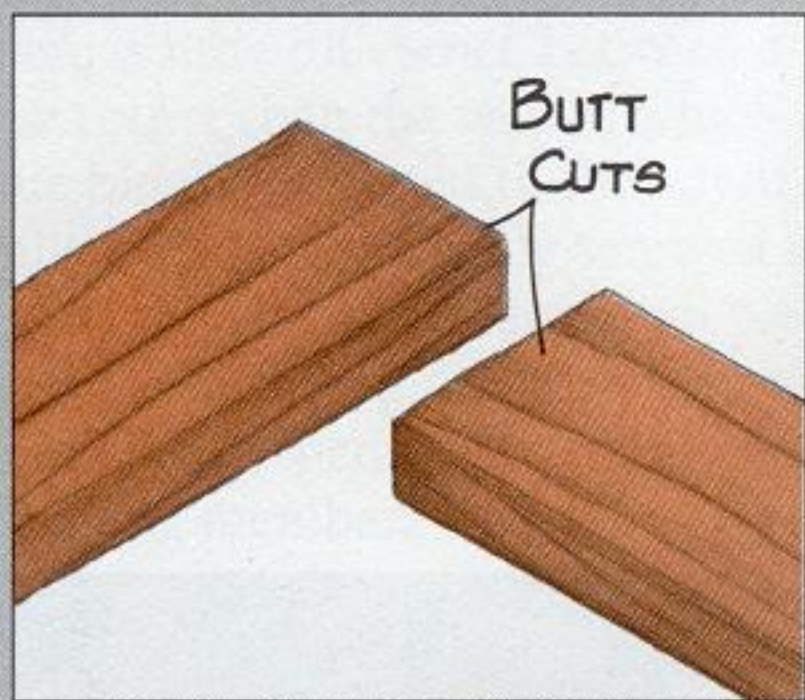

BUTT JOINT

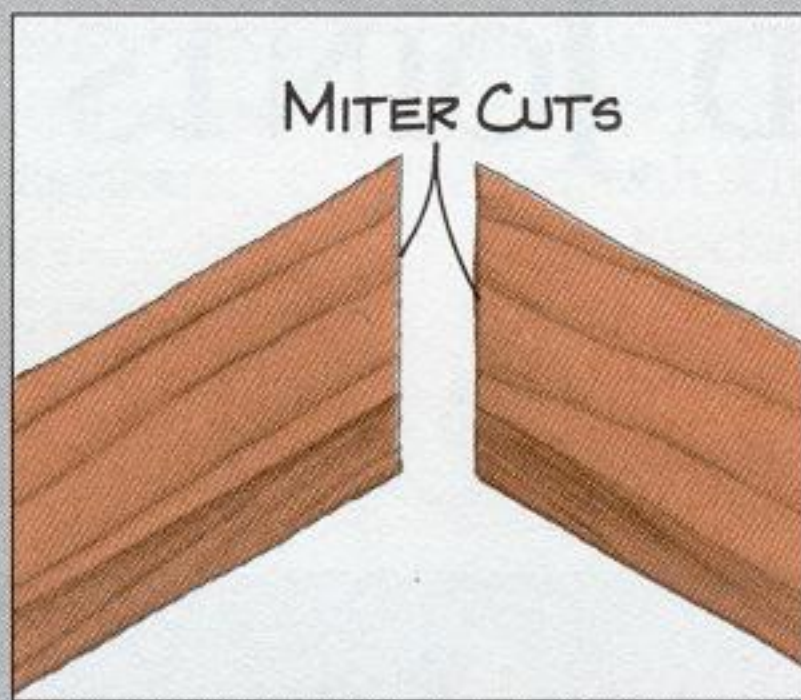

MITER JOINT

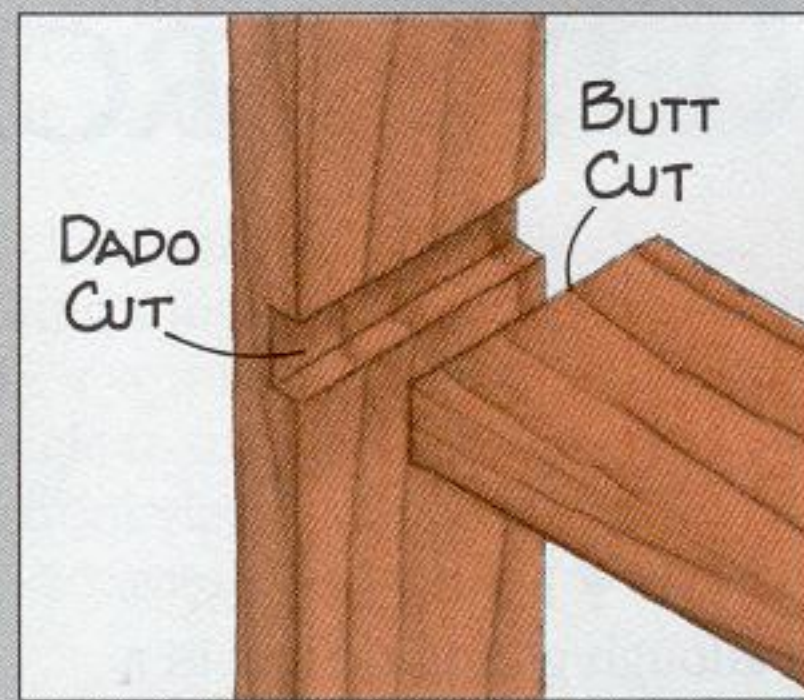

DADO JOINT

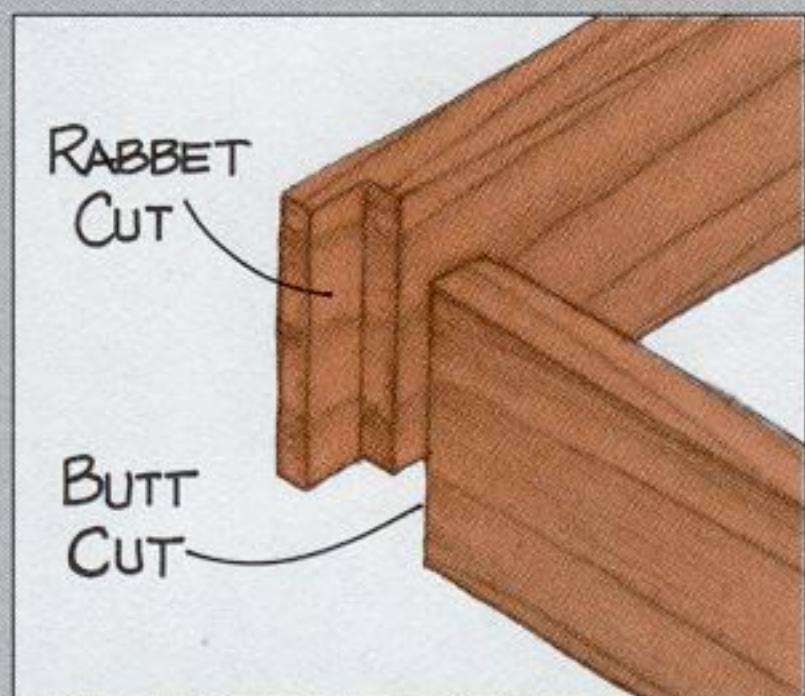

RABBET JOINT

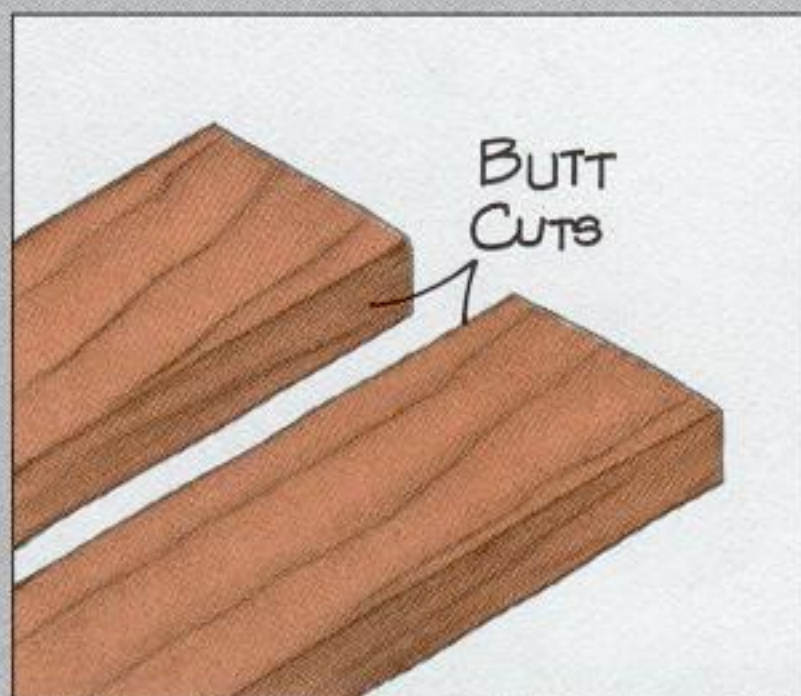

EDGE JOINT

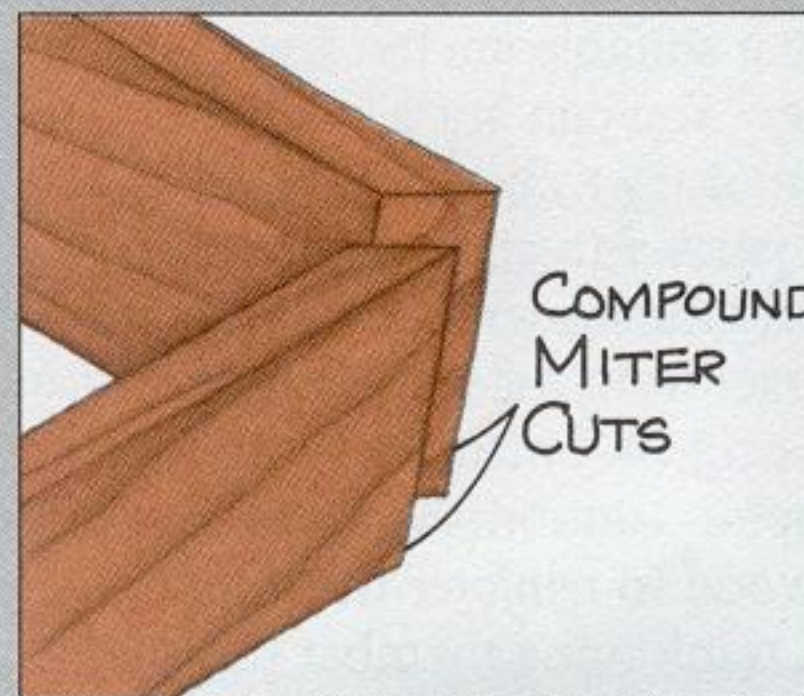

COMPOUND MITER JOINT

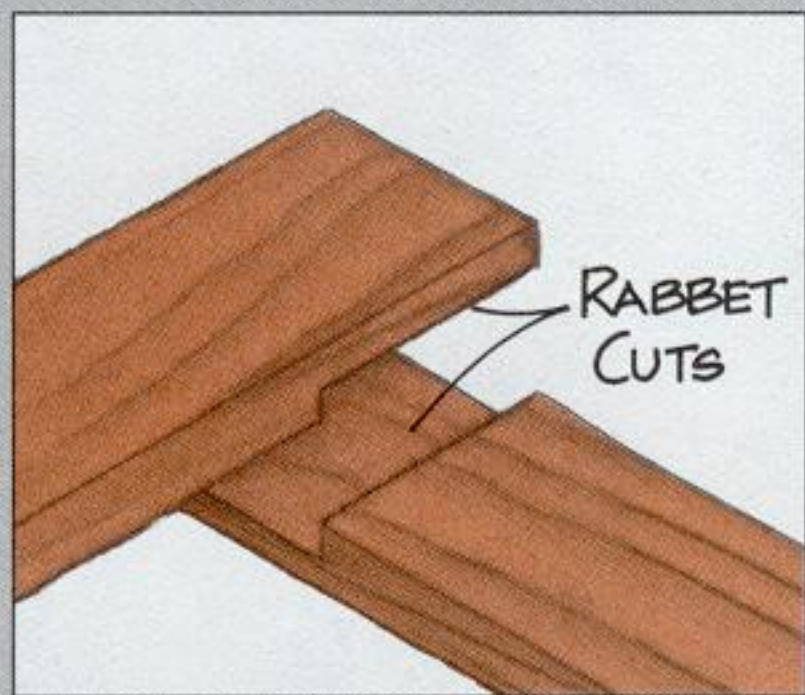

LAP JOINT

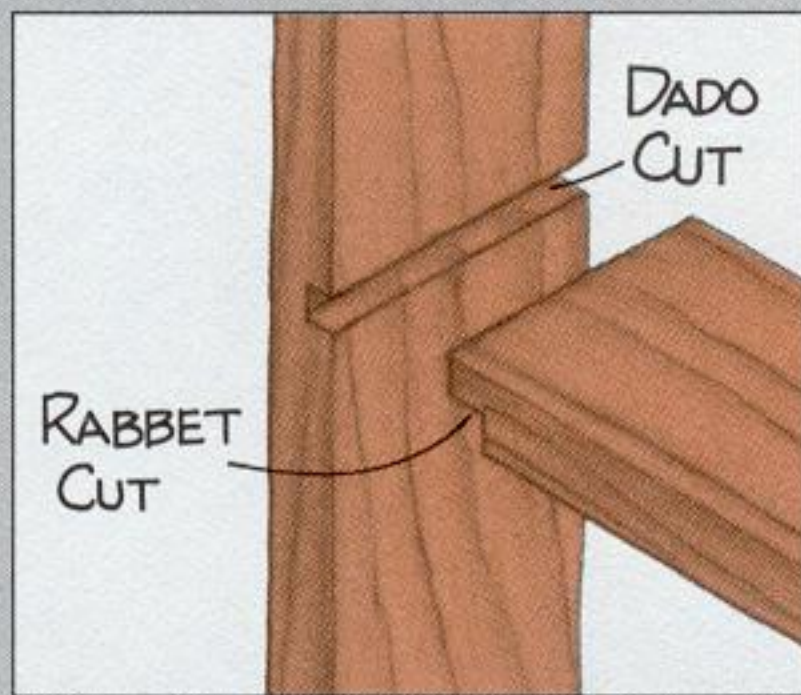

DADO-AND-RABBET JOINT

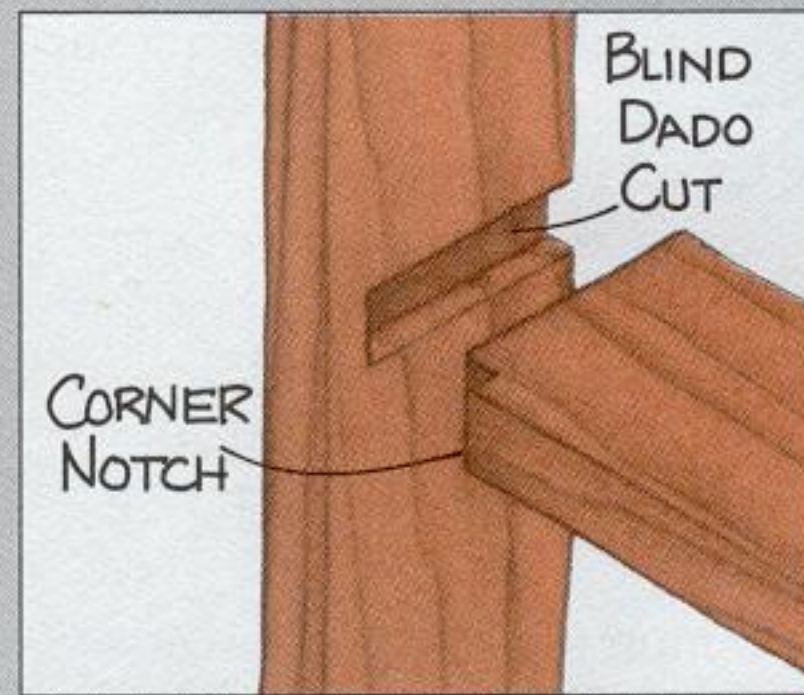

BLIND DADO JOINT

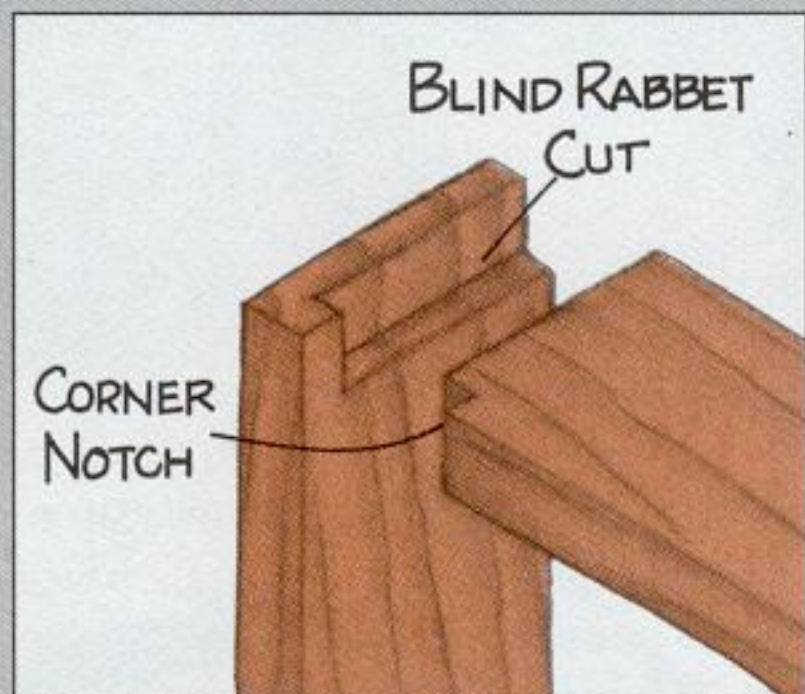

BLIND RABBET JOINT

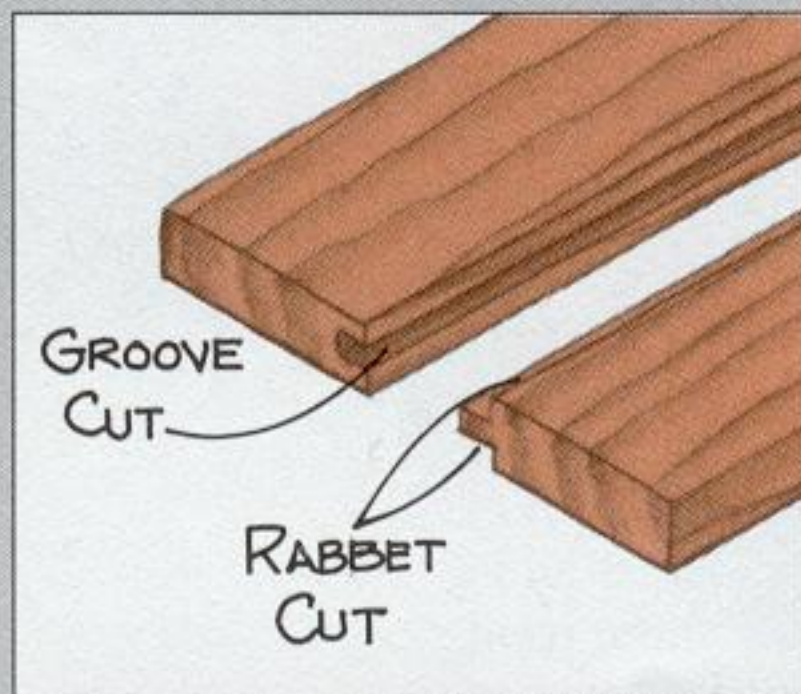

TONGUE-AND-GROOVE JOINT

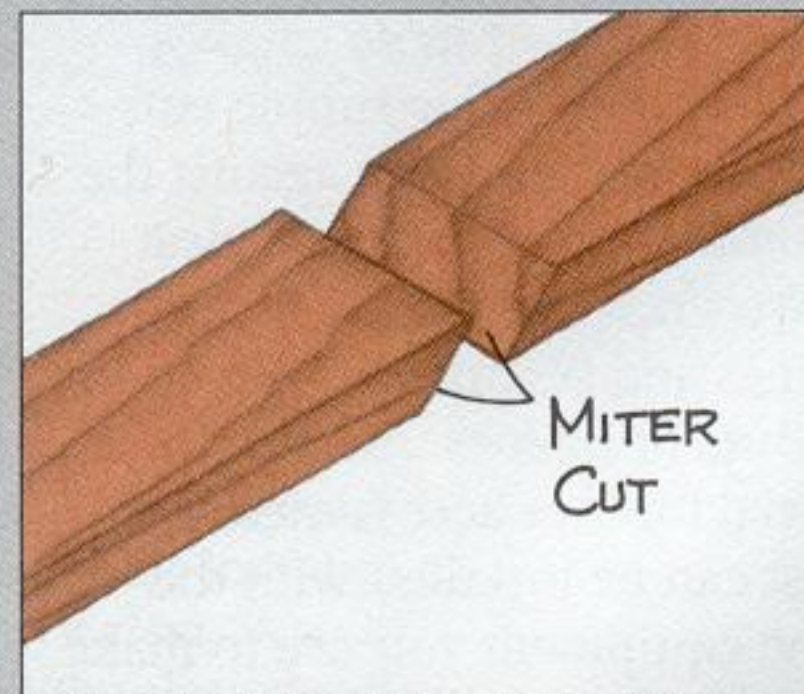

SCARF JOINT

REINFORCED JOINTS

What if there just isn't enough gluing surface in a joint to make a strong glue bond, or there isn't enough stock to provide a suitable anchor for a fastener? You can cut a more intricate joint or try to beef up the adjoining parts, but complex lines or overly thick members might detract from the appearance of the project. Fortunately, there is a simpler solution: Add a *third* piece of wood to *reinforce* the joint.

A reinforcing member ties the two adjoining members together, straddling the joint. Usually, a reinforcement increases the gluing surface in a joint, but it may also provide an anchor for nails or screws. To keep from interfering with the project design, a reinforcing member is usually hidden from sight, either on the inside of an assembly or buried within the joint itself.

Common types of reinforcements include *glue blocks*, *cleats*, *dowels*, *splines*, and wooden plates or *biscuits*. All of these can be installed with a few simple cuts. A glue block butts up against the adjoining parts; so does a cleat. Dowels rest in stopped holes; splines and biscuits are placed in grooves or dados. A few require special tools or accessories, but most can be installed with the same equipment you use to make joinery cuts.

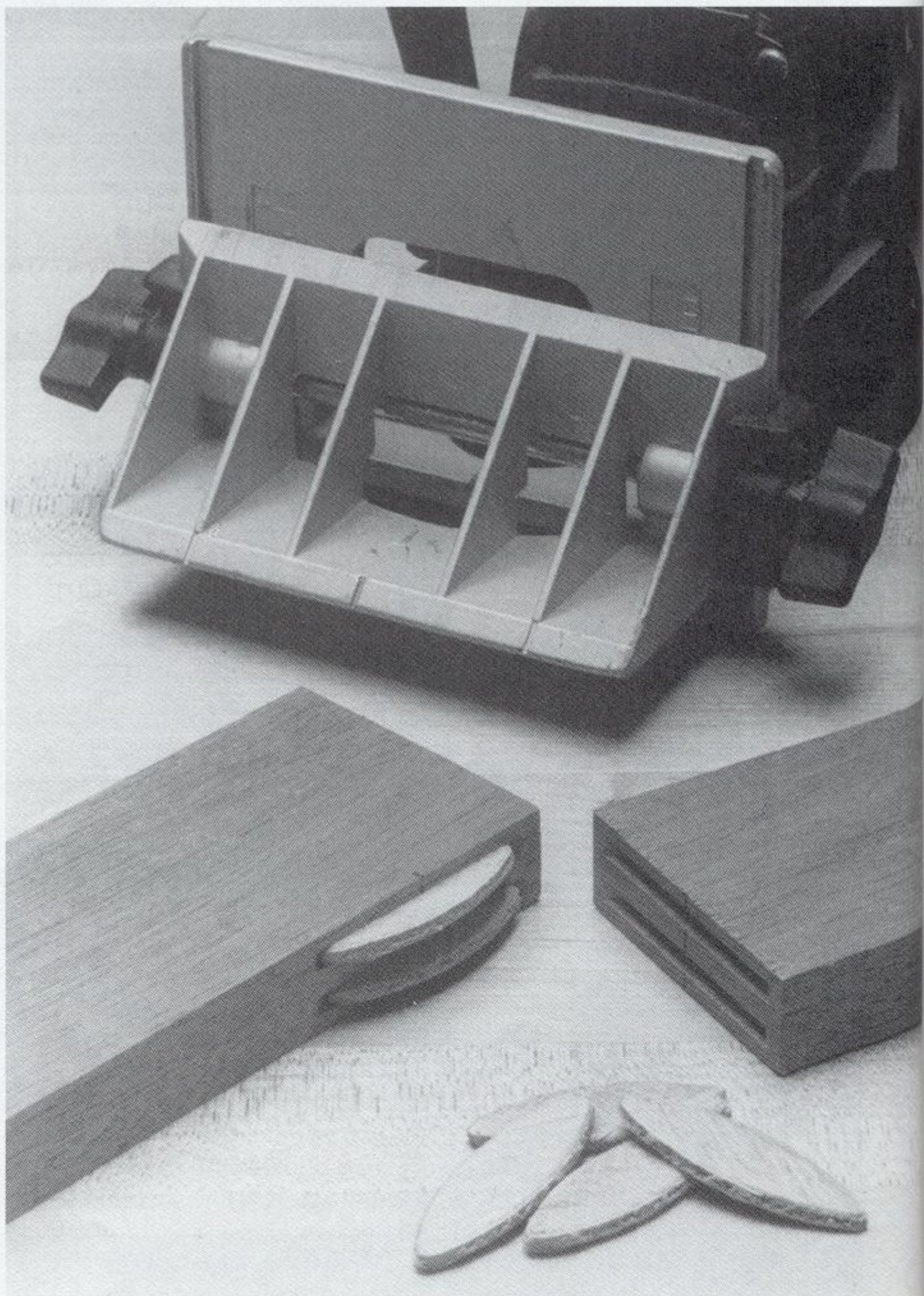

FOUR WAYS TO REINFORCE GLUE BLOCKS AND CLEATS

There is little difference between a glue block and a cleat, other than the way in which each is attached. Glue blocks are glued to the adjoining members, while cleats are normally screwed in place.

Glue blocks usually are small pieces of wood, less than 3 inches long. Because they are short, you can glue them perpendicular to the wood grain of the adjoining members without worrying that the glue joint may restrict wood movement.

Cleats, because they must provide a suitable anchor for screws, are usually larger and longer than glue blocks. When the wood grain of the adjoining parts is perpendicular to that of the cleat, you can cut slots in the cleat for the screw shanks. As the wood expands and contracts, the screws will slide back and forth in the slots.

If the wood grain of one adjoining member is perpendicular to that of the other, you can make a combination glue block and cleat. Arrange this piece so that its wood grain is parallel to the grain of one

adjoining member but perpendicular to the other. Glue the piece to the parallel part and fasten it to the other with screws.

Glue blocks and cleats may be used like gussets, spanning or straddling a joint. (SEE FIGURE 4-1.) More often, they reinforce a corner joint, helping to secure two boards at an angle to one another. The block or the cleat is hidden from view on the *inside* of the angle. (SEE FIGURES 4-2 THROUGH 4-4.)



FOR BEST RESULTS

Always make glue blocks out of strong, *low-density* woods such as poplar, soft maple, or white pine. High-density woods like hard maple, birch, and oak do not form as strong a glue bond as low-density woods.

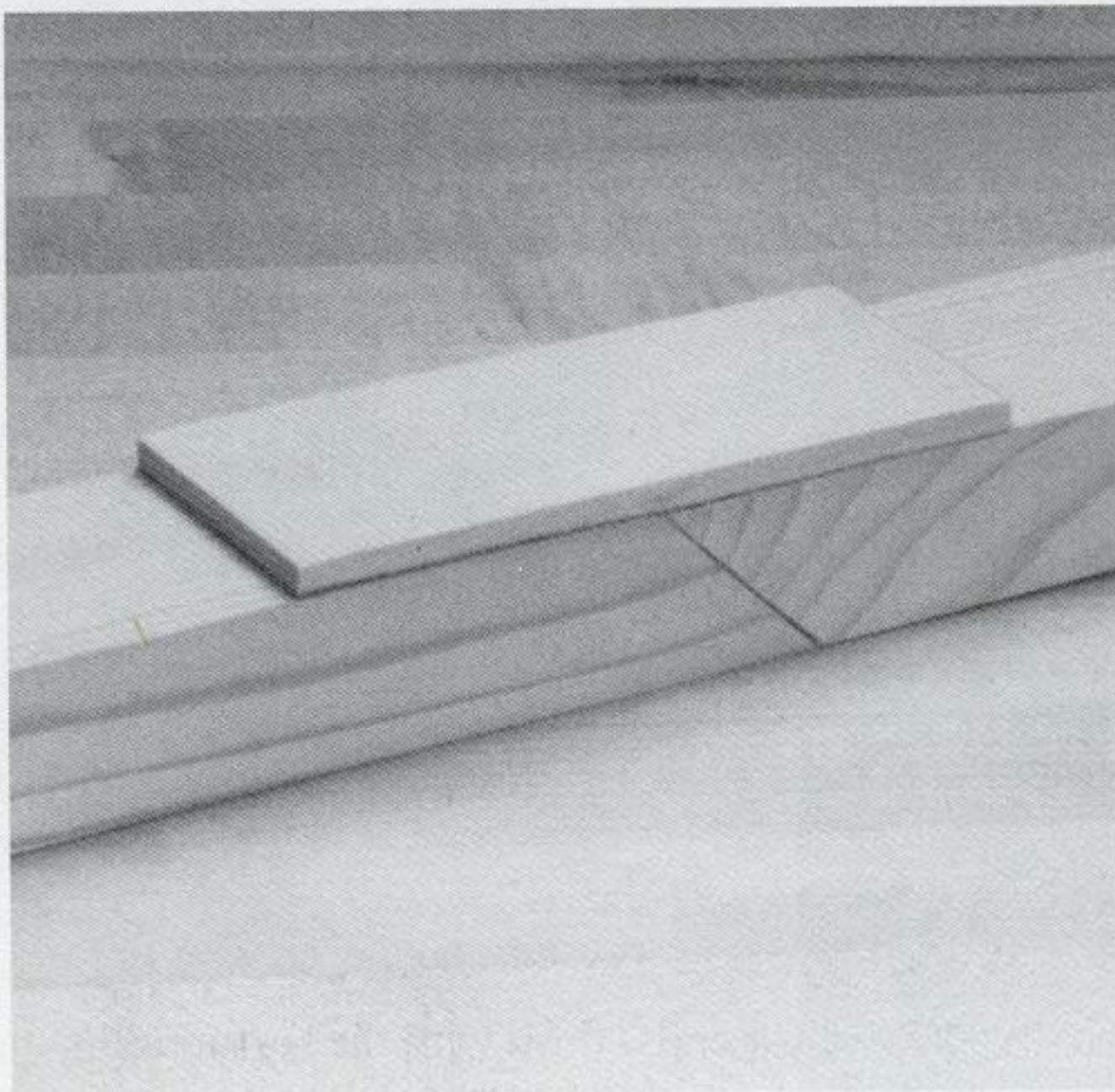

4-1 Because scarf joints are glued end grain to end grain, they are inherently weak. This one has been reinforced with a rectangular glue block that straddles the joint. Note that the grain of the glue block is parallel to that of the adjoining members, and runs *across* the joint.

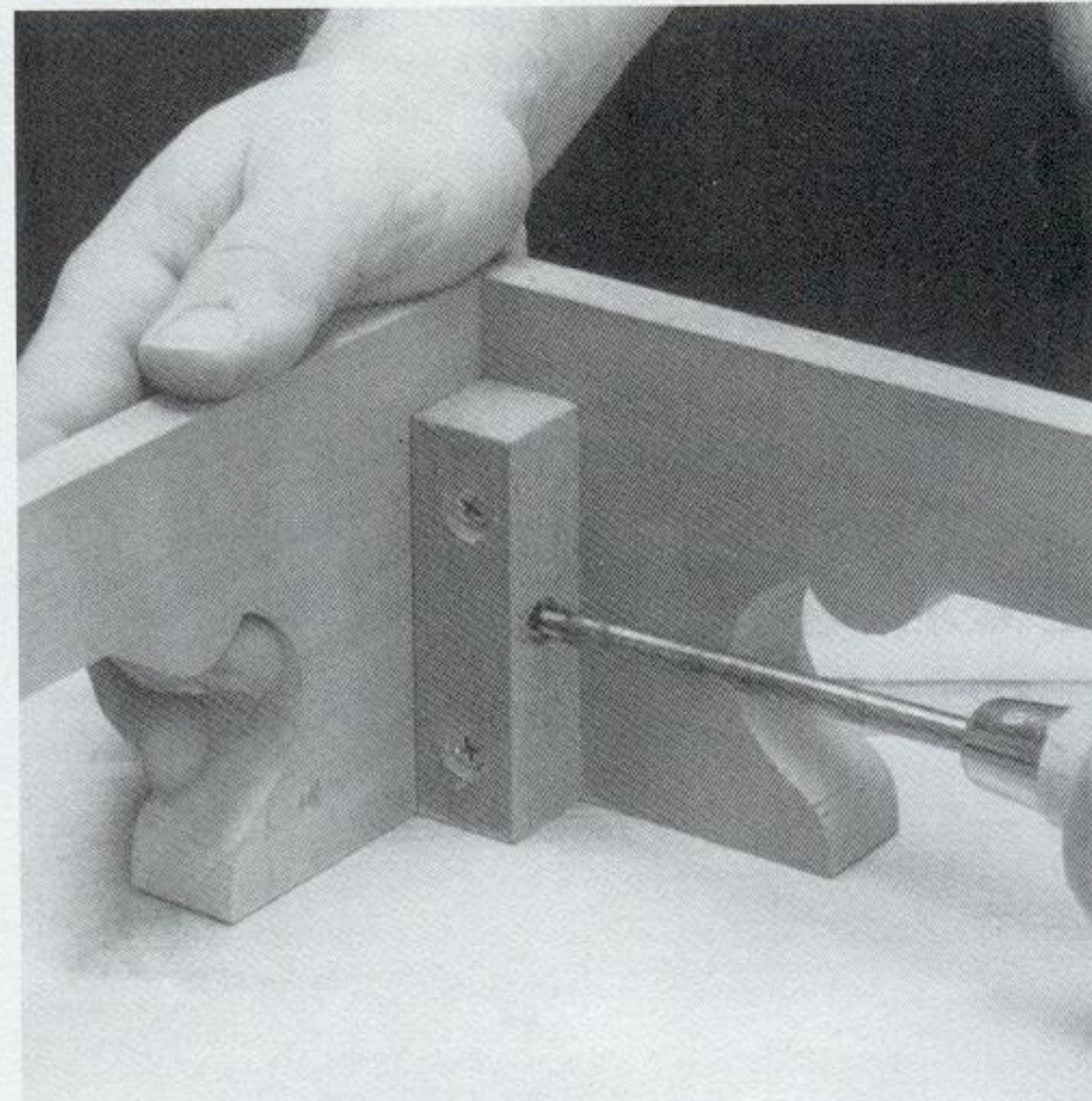

4-2 Miter joints, such as the one that joins the two parts of this bracket foot, are also weak. This joint has been reinforced with a cleat. Wood screws pass through the cleat at right angles, tying the two adjoining parts together.

4-3 The cornice (top) molding on this set of shelves is glued to the front and sides of the case, but there is not enough glue surface to make a strong joint. The joint has been reinforced with glue blocks spaced at regular intervals.

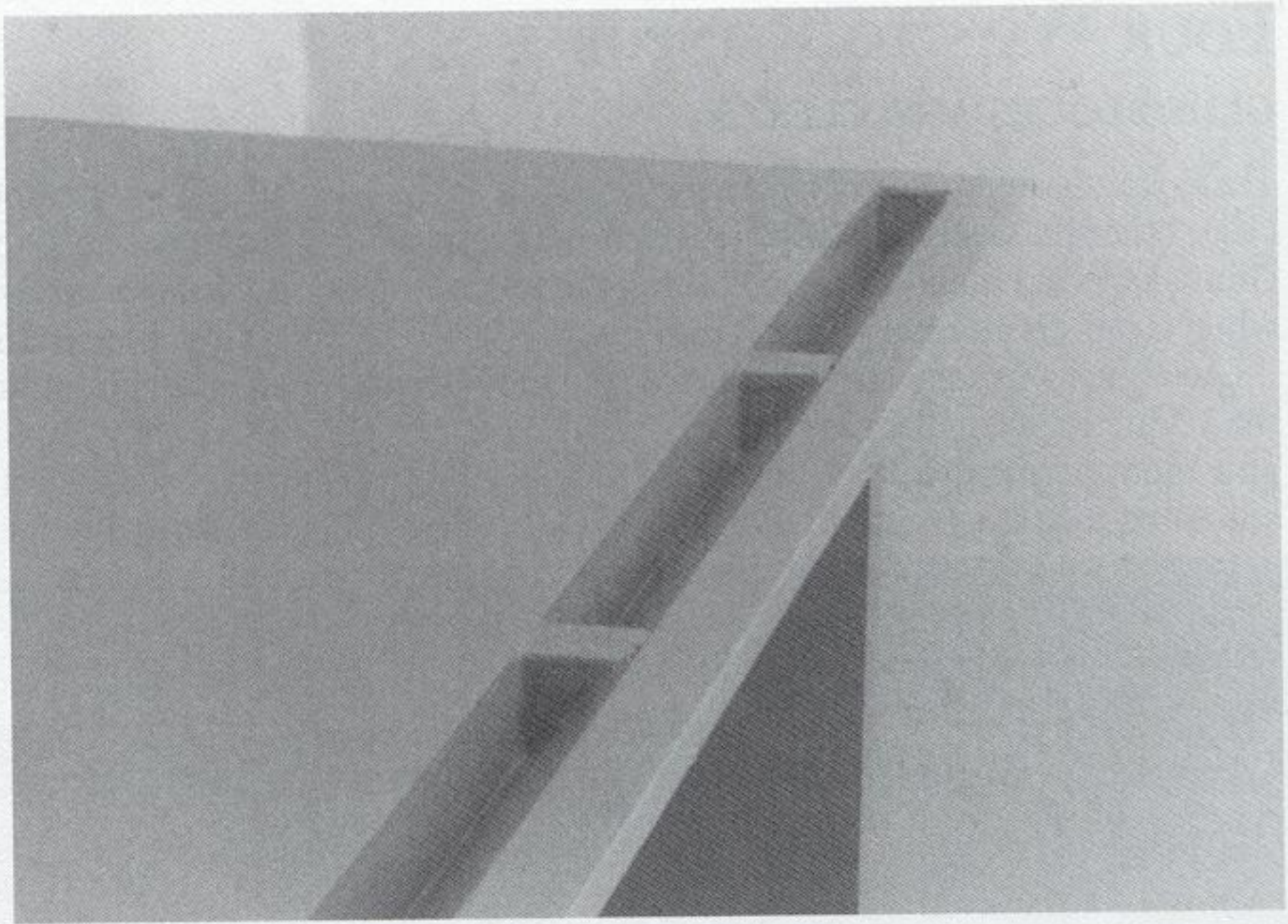

4-4 The strips of wood that hold this tabletop to its aprons are a combination of glue blocks and cleats. The strips are glued to the aprons (where the wood grain runs parallel), but screwed to the tabletop (where it is perpendicular). Note that the screws pass through slots in the strips. This lets the tabletop expand and contract.

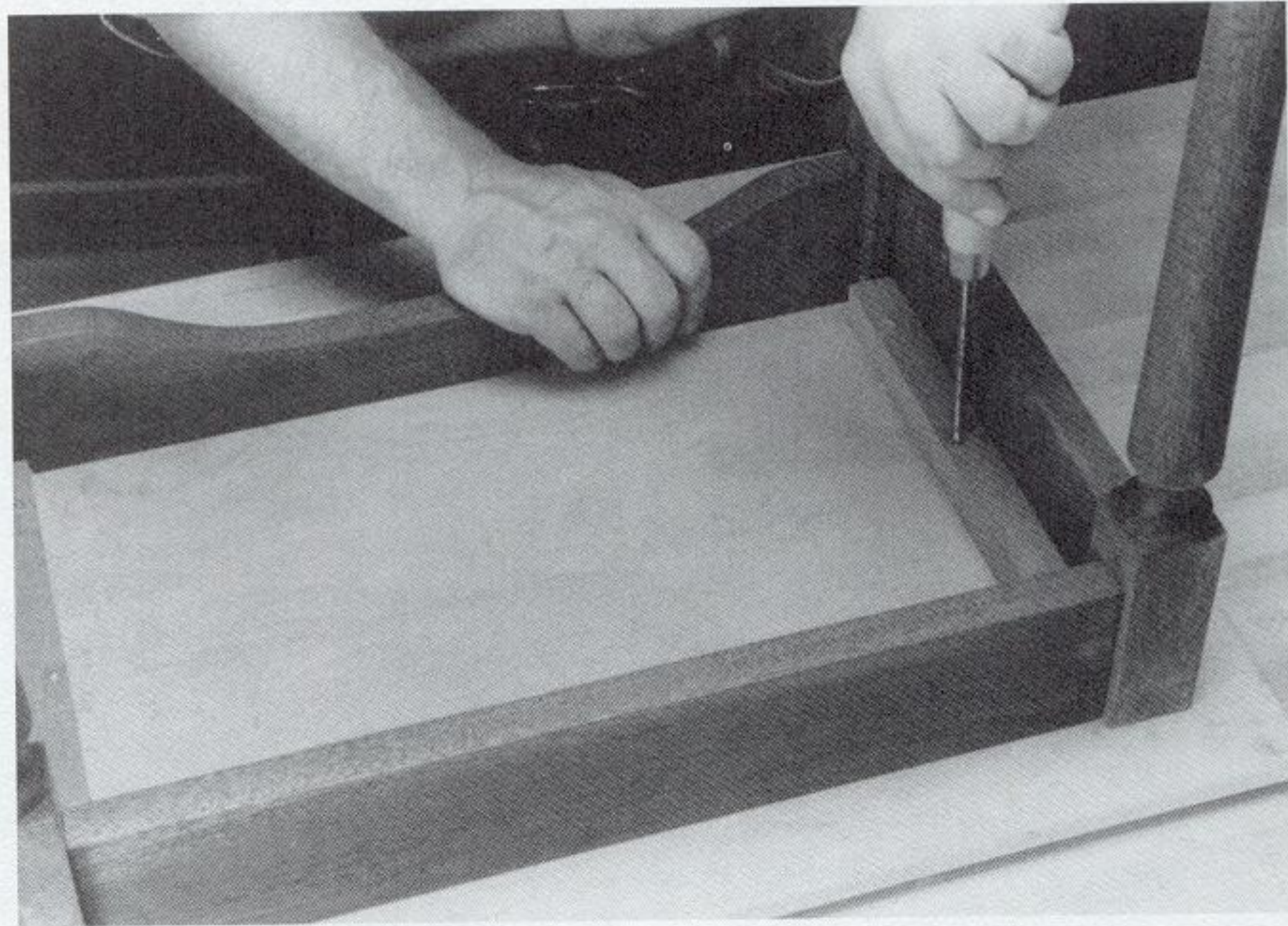

DOWEL JOINTS

A dowel spans a joint *inside* the wood, tying the two adjoining members together. One or both ends of the dowel may be visible. A visible dowel is simple to install. First, glue the adjoining members together. Drill a hole (the same diameter as the dowel) through the first member and either part way into or through the second. Coat the dowel and the inside of the dowel hole with glue, then drive the dowel into the hole before the glue sets. Wait for the glue to dry, and sand

the visible end (or ends) flush with the surrounding wood surface.

More often, the dowels are completely hidden from view. Hidden dowels are more difficult to install; you must drill stopped holes in both of the adjoining parts, and these holes must line up precisely. There are two tools for aligning dowel holes; both are commercially available from some hardware stores and most mail-order woodworking suppliers.

If the two mating surfaces are the same width or thickness, use a *doweling jig* to help drill the dowel holes. Dry assemble the adjoining parts (without glue) and mark where you want to drill the dowel holes. Align the jig with these marks, then drill the holes. (SEE FIGURES 4-5 THROUGH 4-7.)

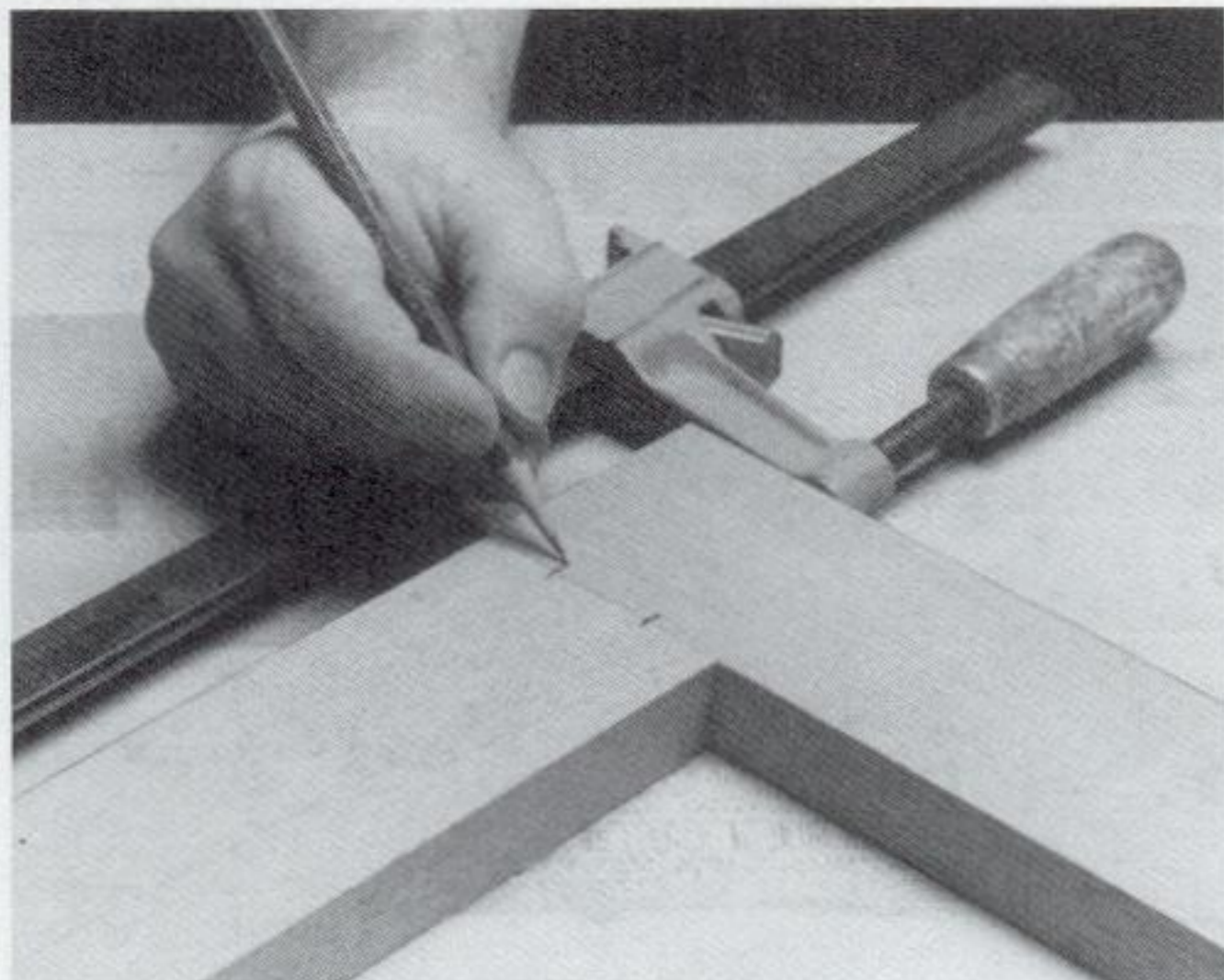

4-5 To make a dowel joint in two boards of the same size, use a doweling jig to align the holes. Match up the mating surfaces of the adjoining boards. Using a sharp pencil, draw a line across the joint and mark both boards wherever you want to install a dowel. (Don't use an awl or knife to lay out this particular joint — it will scratch the visible surfaces of the wood.)

If the two mating surfaces are a dissimilar size or shape, use *dowel centers* to align the holes. These centers are small metal buttons with a point on one end. First, lay out and drill dowel holes in *one* of the adjoining boards. Place dowel centers in these holes and press the boards together. The centers will leave

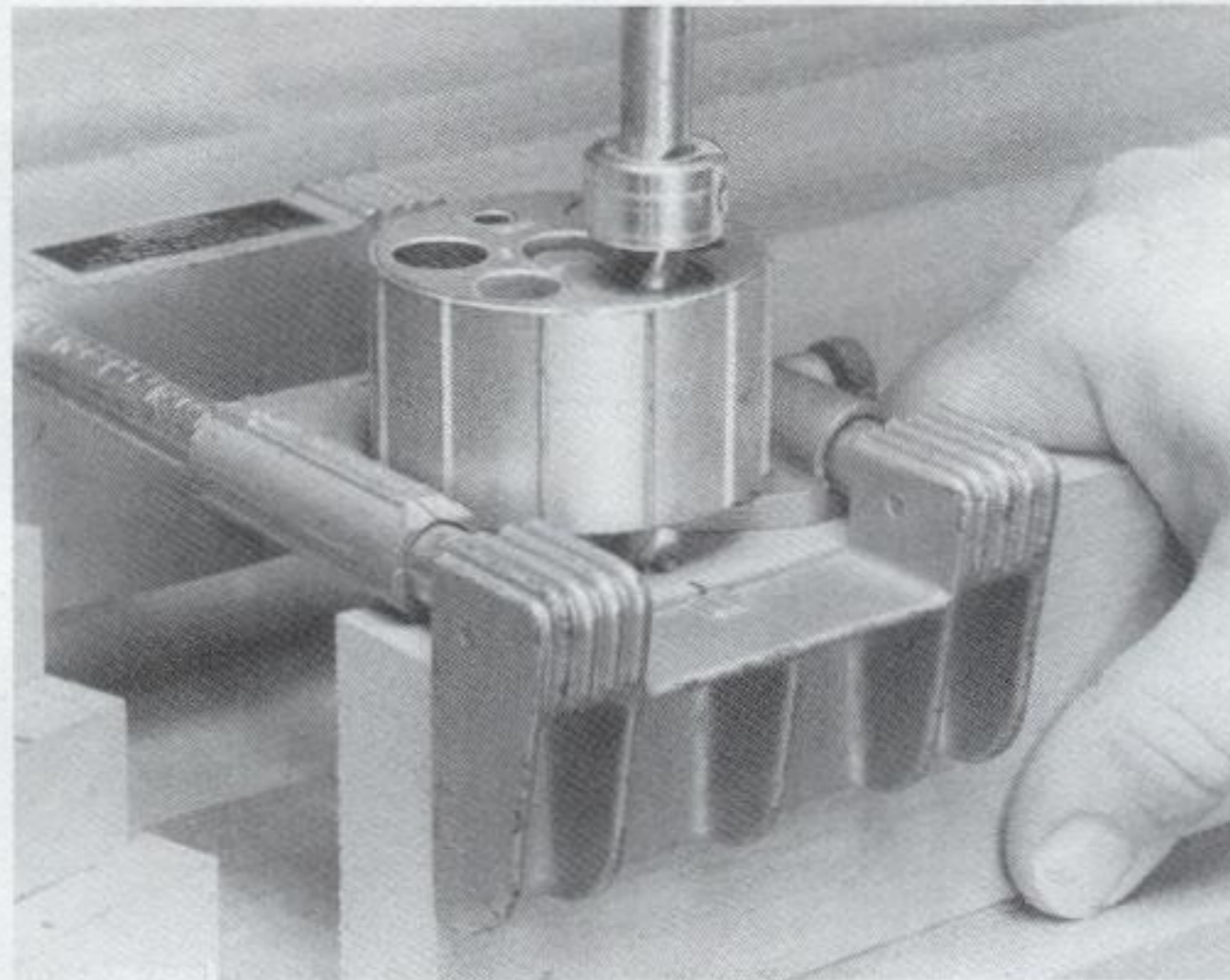

4-6 Align the jig with a mark on one of the adjoining boards and clamp it in place. Bore a stopped hole at the mark, using the jig to guide the drill bit. Repeat for all the marks on both adjoining boards. **Note:** For this jig to work accurately, you must use a drill bit that is the same diameter all along its length, such as a brad-point bit. You cannot use a spade bit or a Forstner bit.

4-7 Dry assemble the joint (without glue) to check the alignment of the dowel holes. Place dowels into the holes in one board and fit it to the other. If the holes are properly aligned, reassemble the joint with glue.

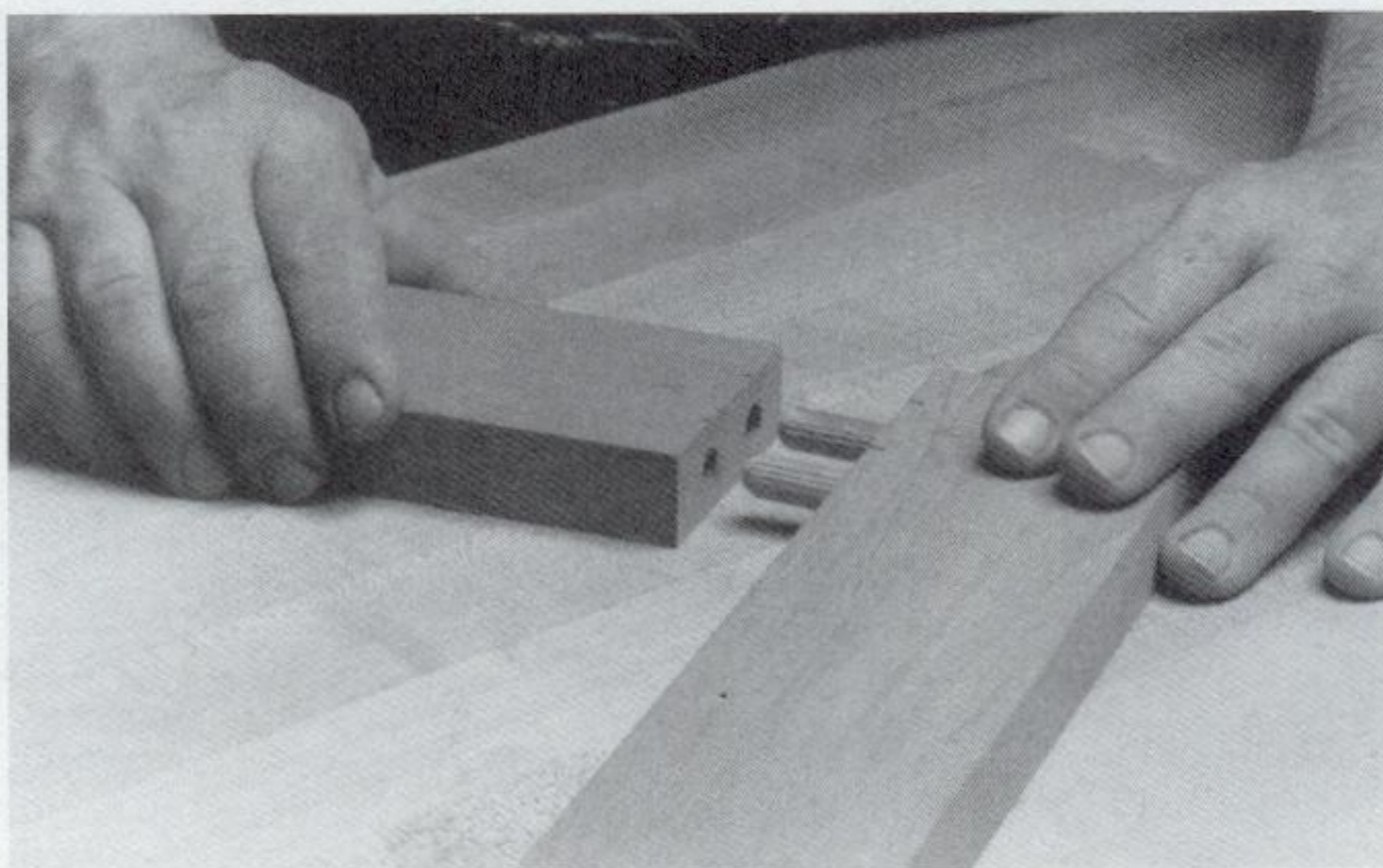

marks on the second board, showing where to drill the matching holes. (SEE FIGURES 4-8 AND 4-9.)

Here are a few additional tips for making dowel joints:

- Dowels that run perpendicular to the wood grain of the adjoining parts should not be over 3 inches long. Otherwise, they may restrict the wood movement and cause the joint to split.

- Drill stopped dowel holes about $\frac{1}{16}$ inch deeper than you actually need to. This will give the excess glue inside the hole somewhere to go.

- When you slide a dowel into place, most of the glue is wiped off the wood surface. To keep the joint from being “starved” for glue, use dowels with grooves cut into their surfaces. These dowels are available commercially, or you can make your own. (SEE FIGURE 4-10.)

4-8 Use dowel centers to align dowel holes when joining boards of different widths or thicknesses. First, drill stopped holes in just one of the adjoining parts. Place the dowel centers in these holes so the points face outward. Align the adjoining parts and press them together. If the wood is very hard, you may have to rap one part or the other with a mallet to get the dowel centers to leave a visible mark.

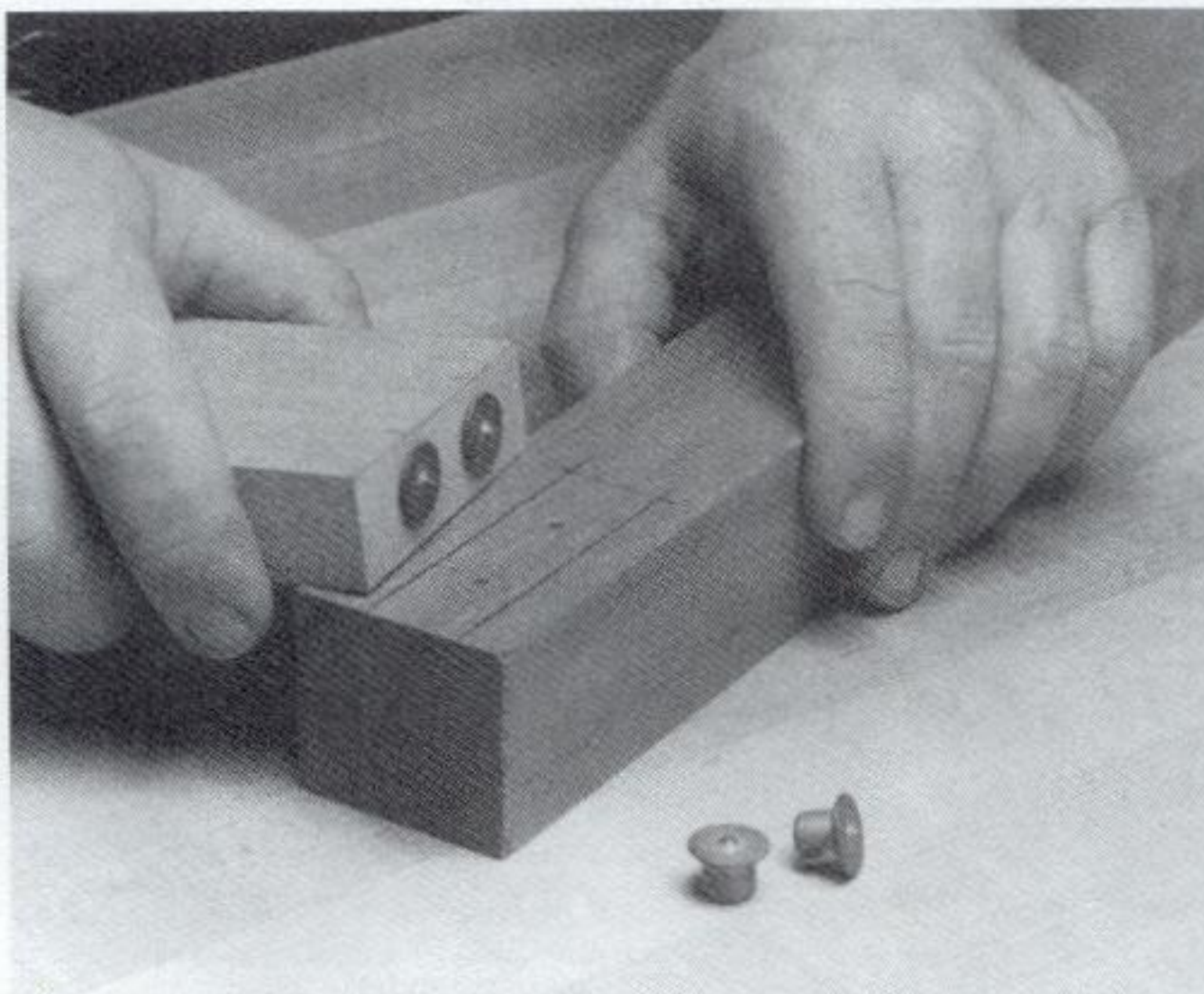
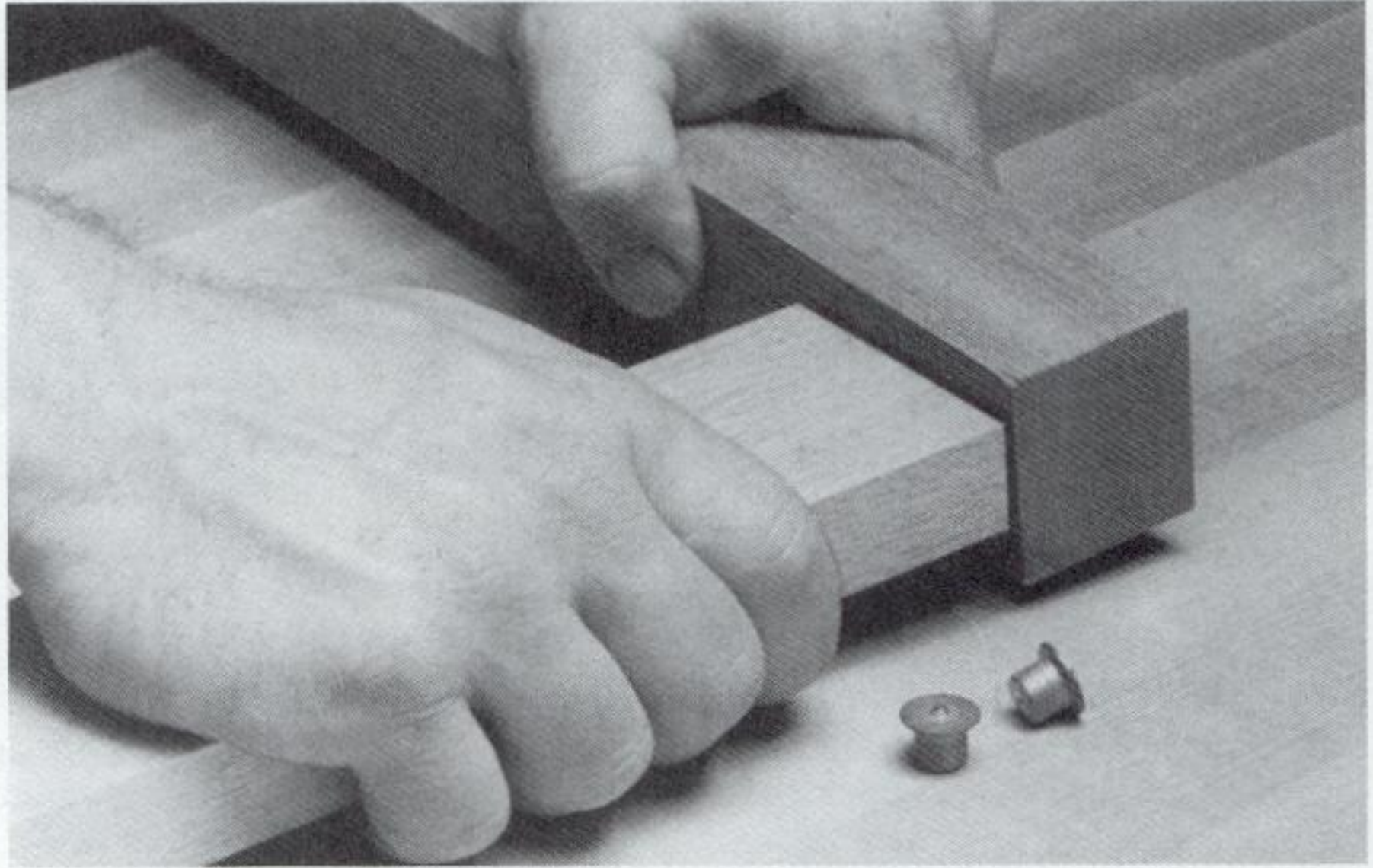

4-9 When you take the boards apart, the dowel centers will have made indentations in the surface of the part that hasn't yet been drilled. Drill stopped holes at these marks, check the alignment of the holes, then assemble the joint with dowels and glue.

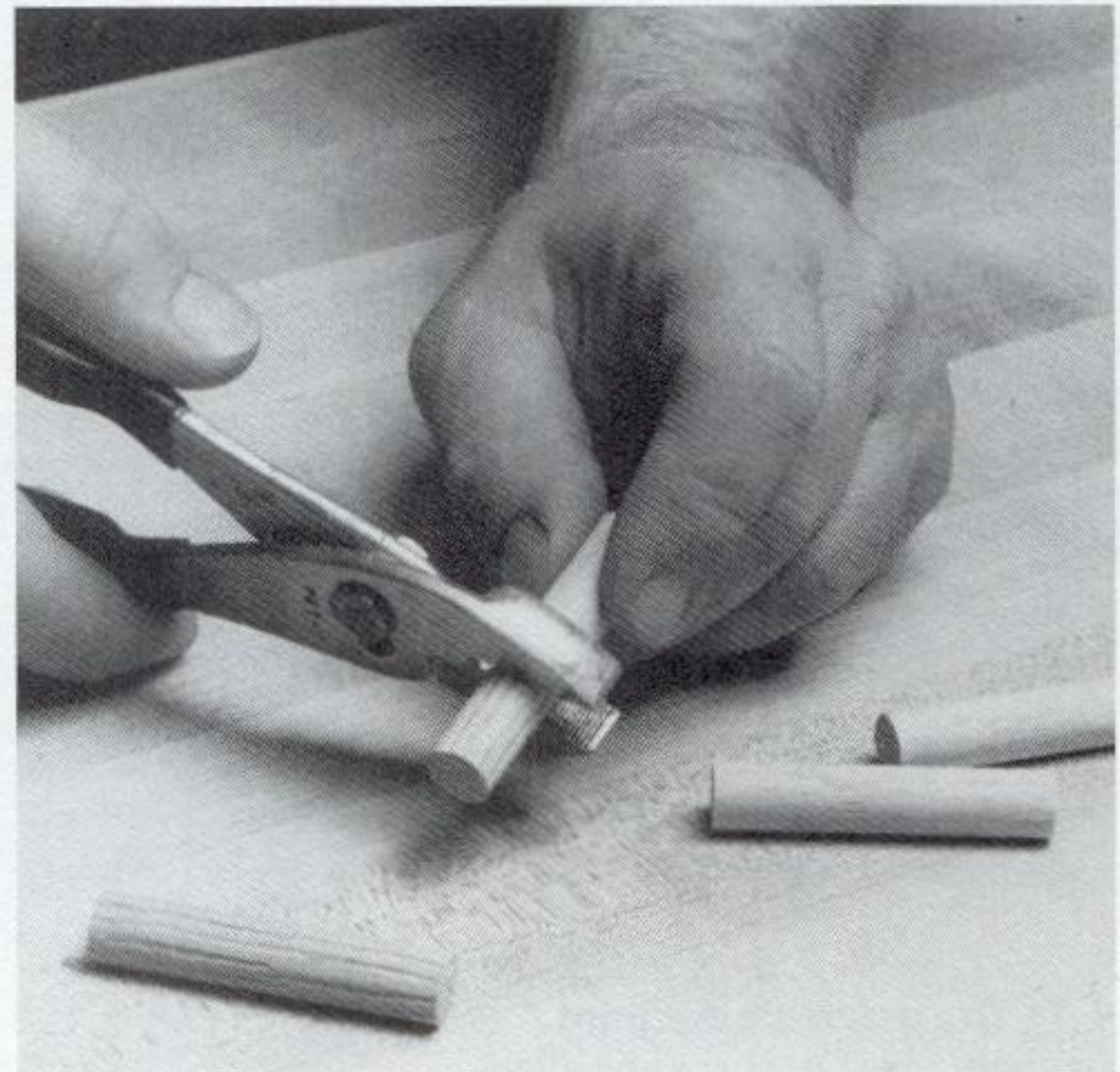

4-10 To cut glue grooves in dowels, squeeze the stock gently between the jaws of a pair of pliers. Be careful not to squeeze so hard that you crush the wood fibers.

SPLINE JOINTS

A spline is a small board, usually just $\frac{1}{8}$ to $\frac{1}{4}$ inch thick, that spans the joint between two boards. The spline rests in two matching grooves, one in each of the adjoining boards. (You can also install a spline in matching rabbets or dados if needed.) Splines can be made of solid wood or plywood — the grain direction of the adjoining parts dictates which material is best. If you make splines from solid wood, the spline wood grain must run *across* the joint, tying the two adjoining boards together. (SEE FIGURE 4-11.)

Making a spline groove is no different from making an ordinary groove. Use a saw blade, a dado cutter, or a router bit to cut a groove as wide as the spline is

thick. Adjust the depth of cut to about $\frac{1}{32}$ inch *more* than half the spline's width. (This allows space for excess glue.) Cut *identical* grooves in each of the adjoining surfaces. (SEE FIGURES 4-12 AND 4-13.)

Dry assemble the joint to check the alignment of the grooves and the fit of the spline. Half the spline should fit in one groove and half in the other, with just a little side-to-side "slop." If everything checks out, spread glue on the adjoining surfaces, in the spline grooves, and on the splines. Assemble the parts.

Spline joints are especially useful for reinforcing miter joints. Depending on how a miter joint is oriented, you can run the splines either horizontally

4-11 Make splines for spline joints from solid wood or plywood, depending on the grain direction of the adjoining parts. If the wood grain runs *perpendicular* to the joint, as shown on the left, use *solid wood*. Because the wooden spline must run across the joint, its grain will be parallel to that of the adjoining members; all the parts will expand and contract together. If the wood grain runs *parallel* to the joint, as shown on the right, use *plywood*. Plywood is relatively stable, as is wood along the grain. If you make this spline from solid wood, the adjoining members will restrict its movement and the joint will soon split.

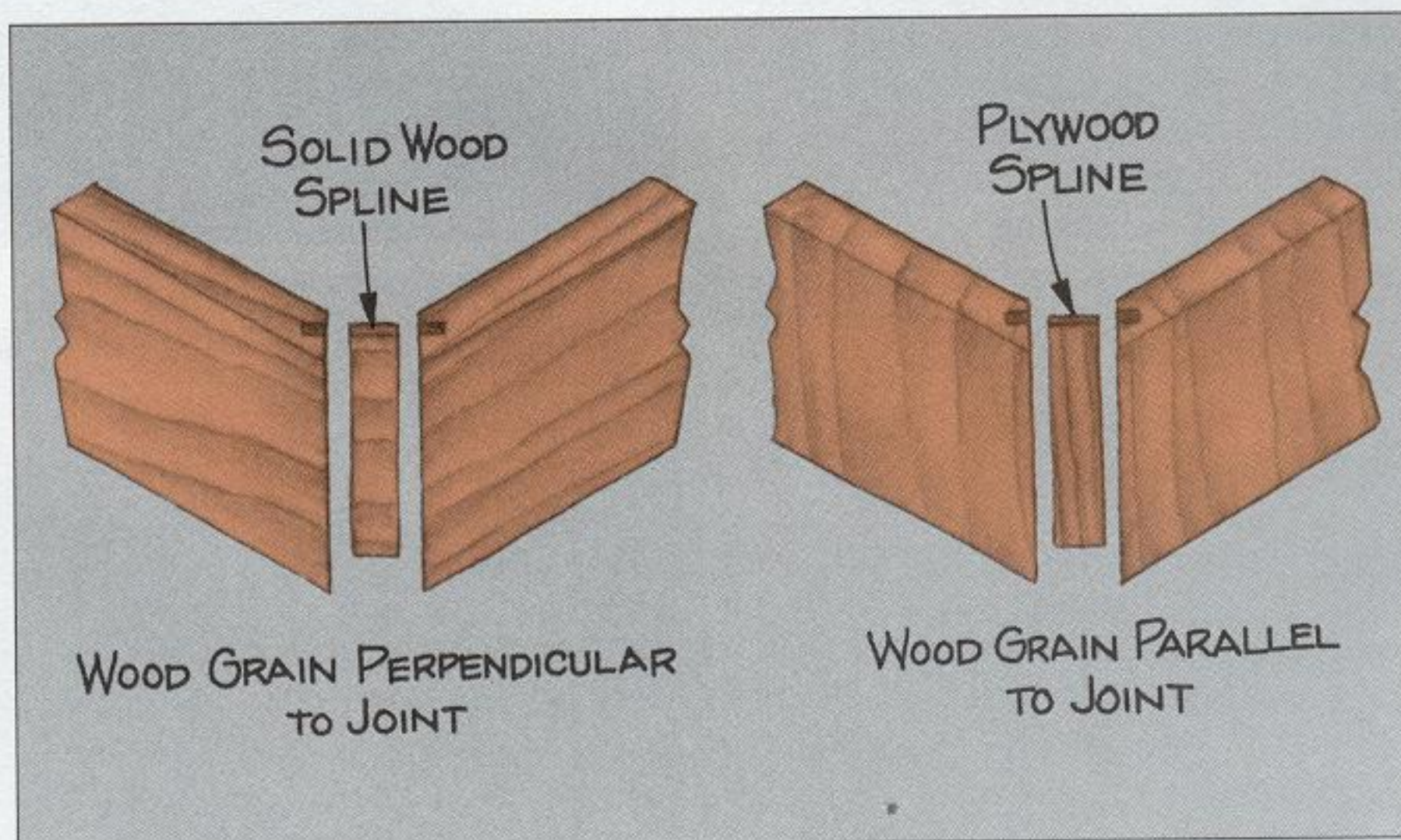

4-12 Cutting spline grooves is no different than cutting ordinary grooves, but the grooves must be identical and they must be positioned carefully on the adjoining parts. To make sure they are, clearly mark the sides of the boards so you know which surfaces are the inside and outside, top and bottom, left and right — whichever combination applies. Cut each matching groove with like surfaces facing in the same direction. For example, when attaching edging to a tabletop, mark the top and bottom surfaces of both the tabletop and the edging. Cut a spline groove in the *edges* of the tabletop, keeping the bottom face turned away from the fence.

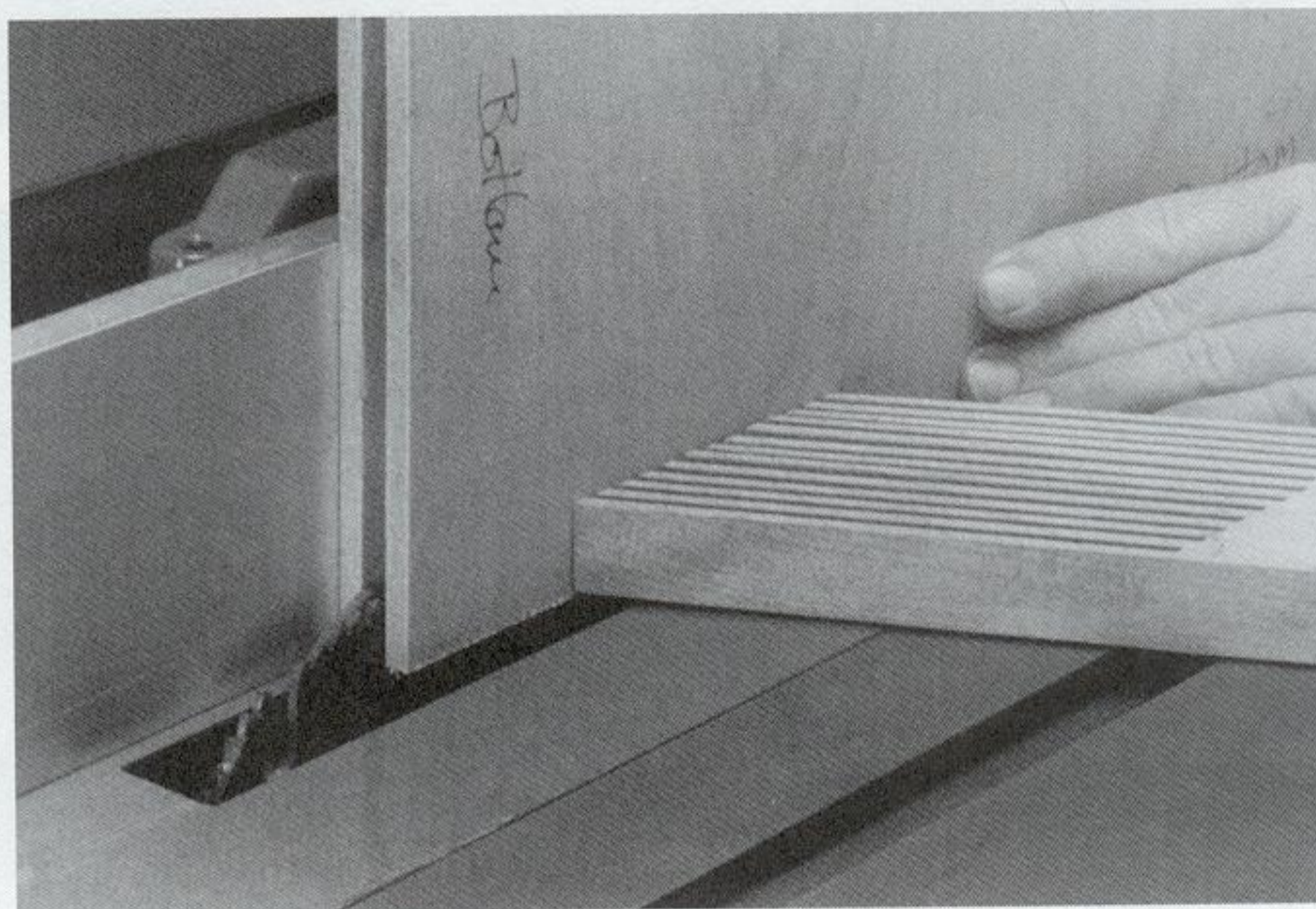

or vertically. (SEE FIGURES 4-14 AND 4-15.) You can also have a choice of whether to cut the spline *before* or *after* you assemble the miter joint. Splined miters in which the grooves are cut *after* the parts have been assembled are sometimes referred to as open spline

joints, since both ends of each spline are clearly visible. (SEE FIGURES 4-16 AND 4-17.) The “Splined Miter Jig” shown on page 56 will hold workpieces at the proper angle to the cutter when making grooves for both open- and regular-splined miter joints.

4-13 Cut a matching groove in the inside *faces* of the edging, keeping the bottom edges turned away from the fence. When the joints are assembled with splines, the top face of the tabletop will be flush with the top edges of the edging.

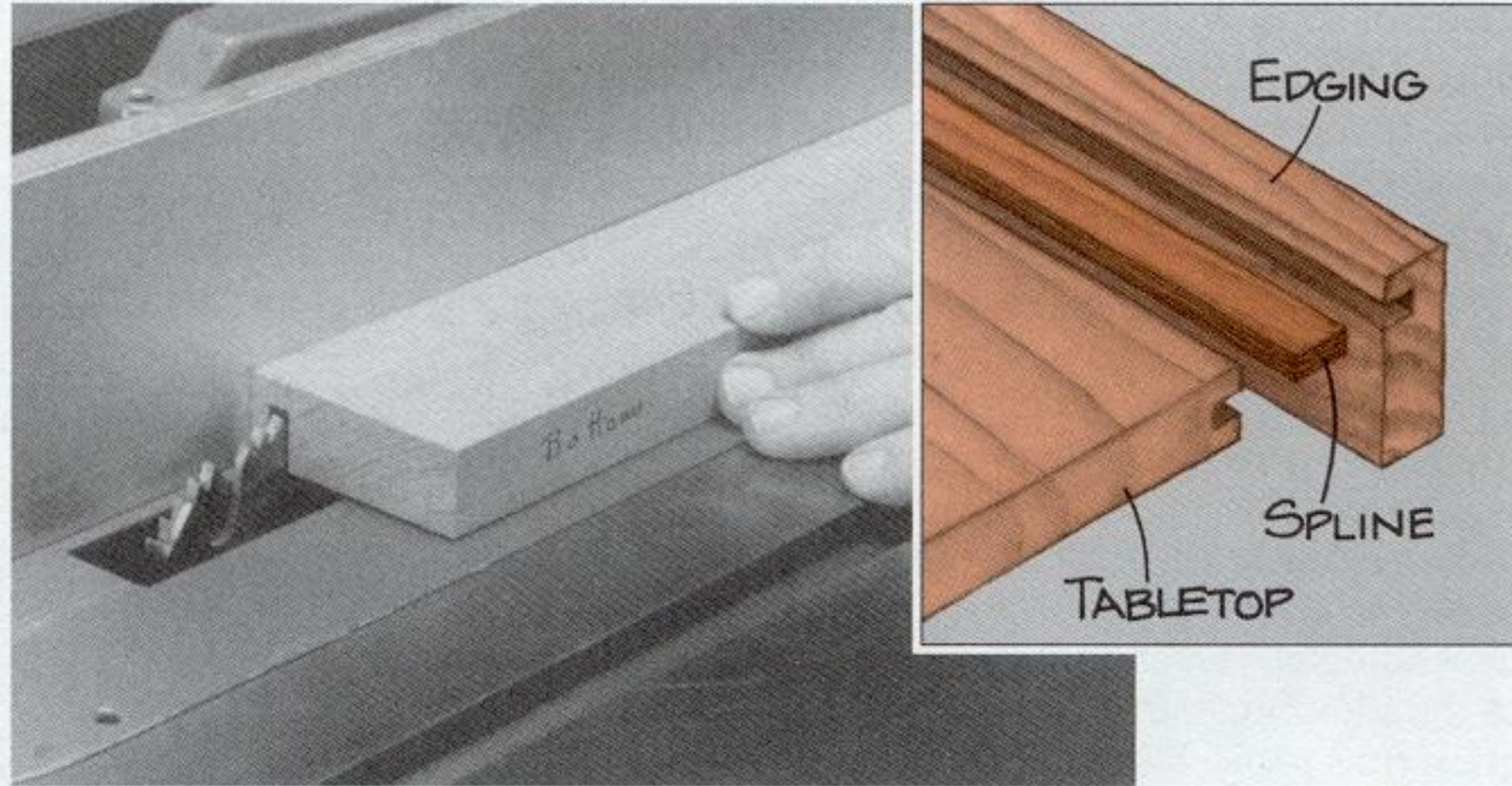

4-14 When making splined miter joints, you can orient the splines either horizontally or vertically. If the parts are to be joined so the *faces* are flush (as in a picture frame), cut the grooves so the splines will be *horizontal*. Mount the workpiece in a jig to hold the mitered surface flat on the worktable. Use the fence to guide the jig and workpiece across the cutter.

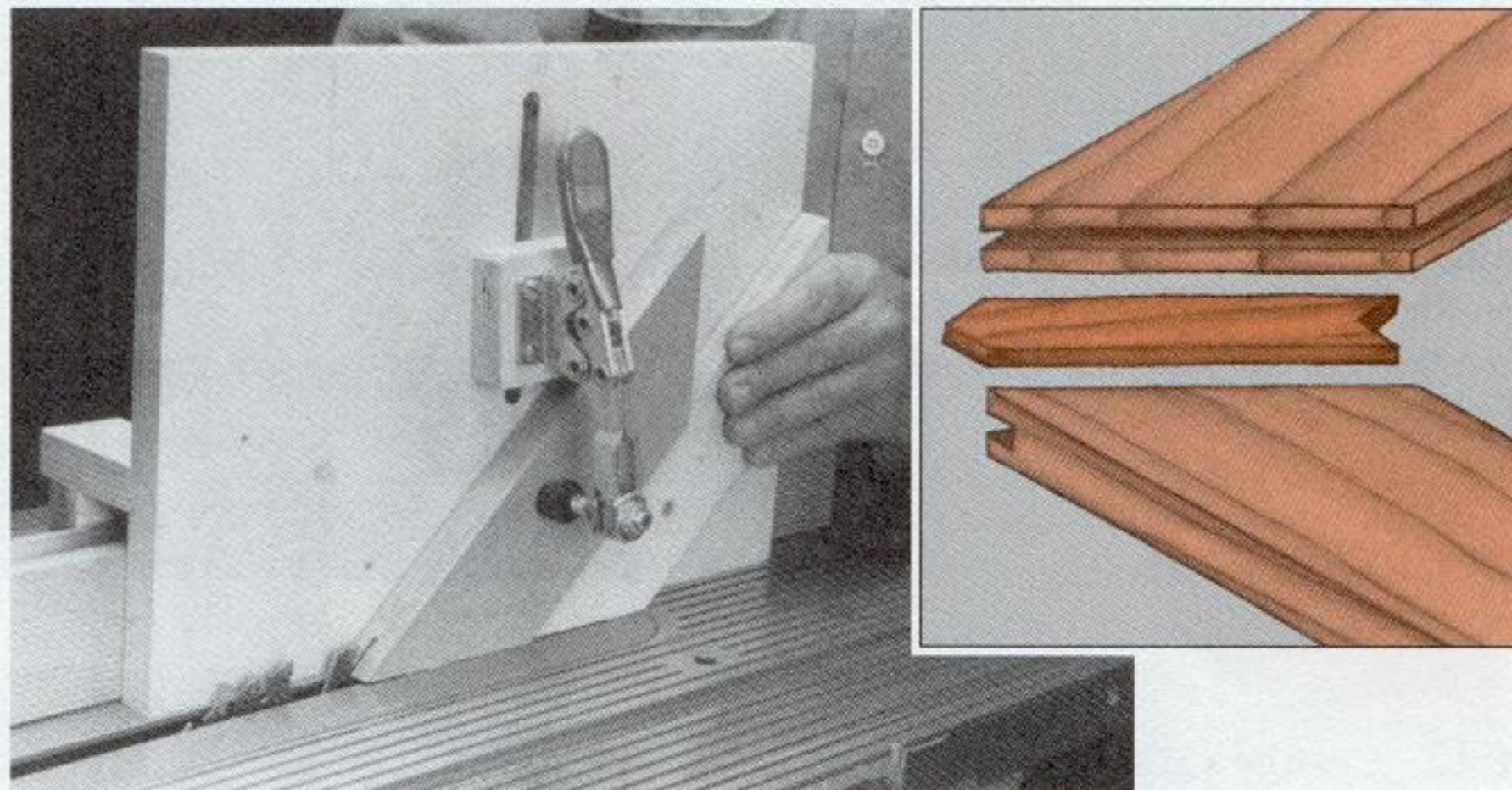

4-15 If the parts are to be joined so the *edges* are flush (like the mitered sides of a small box), cut the grooves so the splines will be *vertical*. Use the miter gauge to guide the workpiece, holding it so the inside face is flat on the worktable. Tilt the blade or cutter 90 degrees from the mitered surface. (If the miter was cut at 45 degrees, tilt the cutter to 45 degrees — $45 + 45 = 90$.) Use the fence to position the workpiece in the miter gauge.

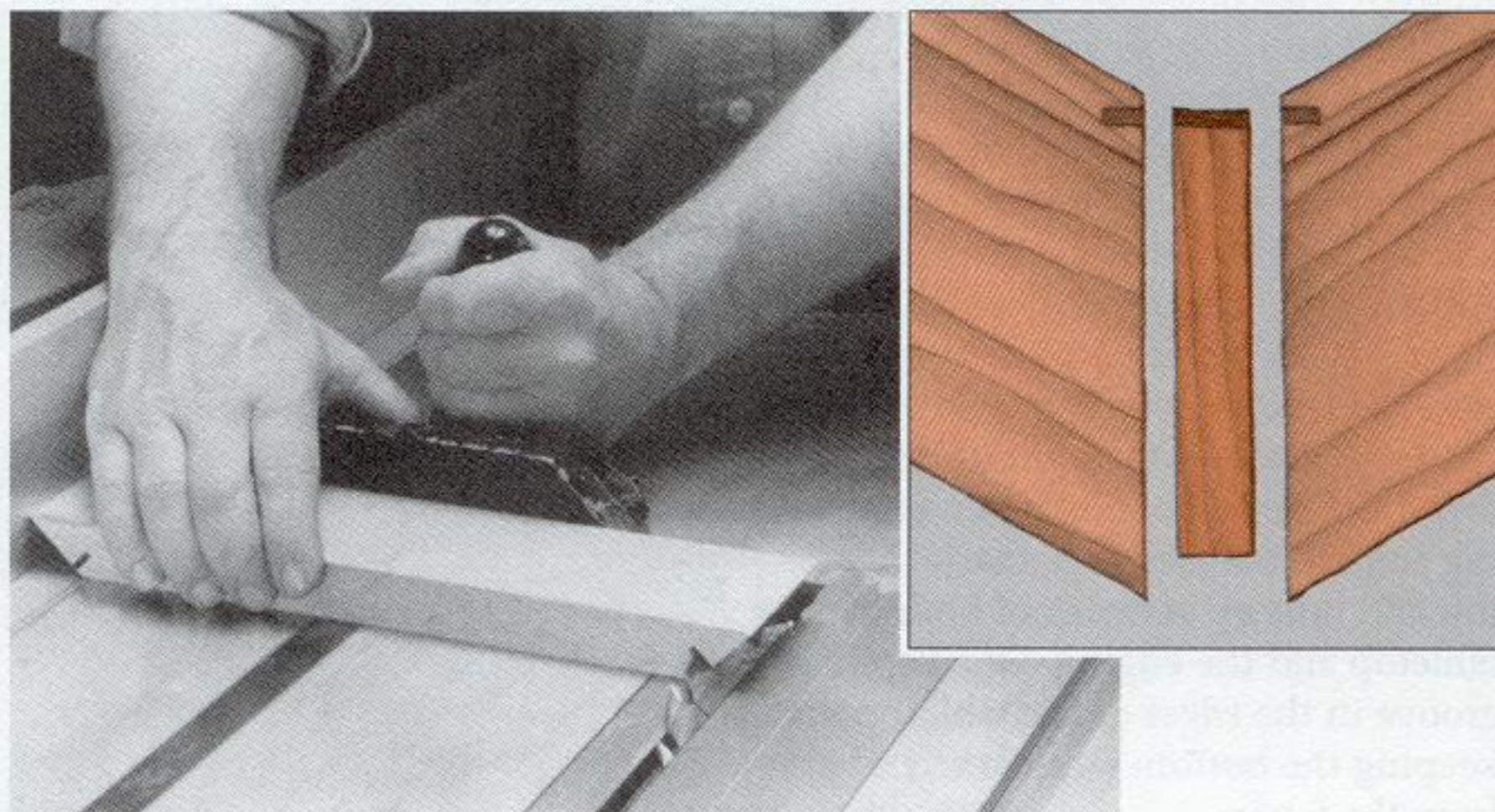



FOR BEST RESULTS

When using vertical splines to reinforce miter joints, position the grooves as close to the *inside* surfaces as possible. If these grooves are too close to the

outside surfaces, the mitered ends of the adjoining parts will be weak.

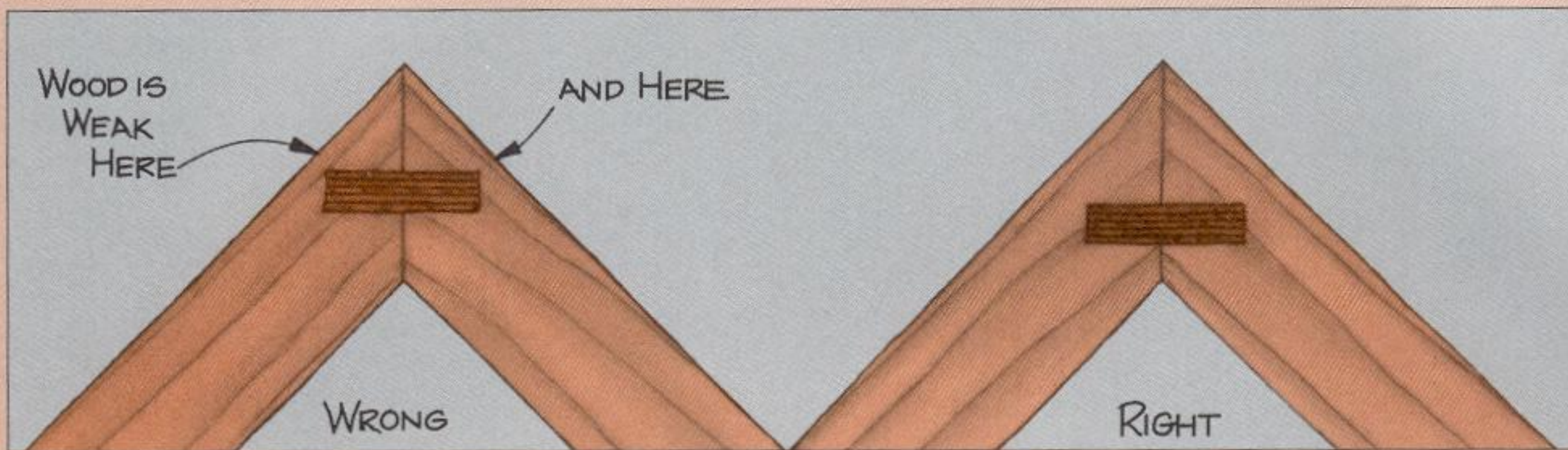

4-16 To make an open-splined miter joint, assemble the adjoining parts with glue. Let the glue dry completely, then cut a *horizontal* spline groove through each of the assembled corners. Use the “Splined Miter Jig” on page 56 to hold the workpieces while you cut the grooves.

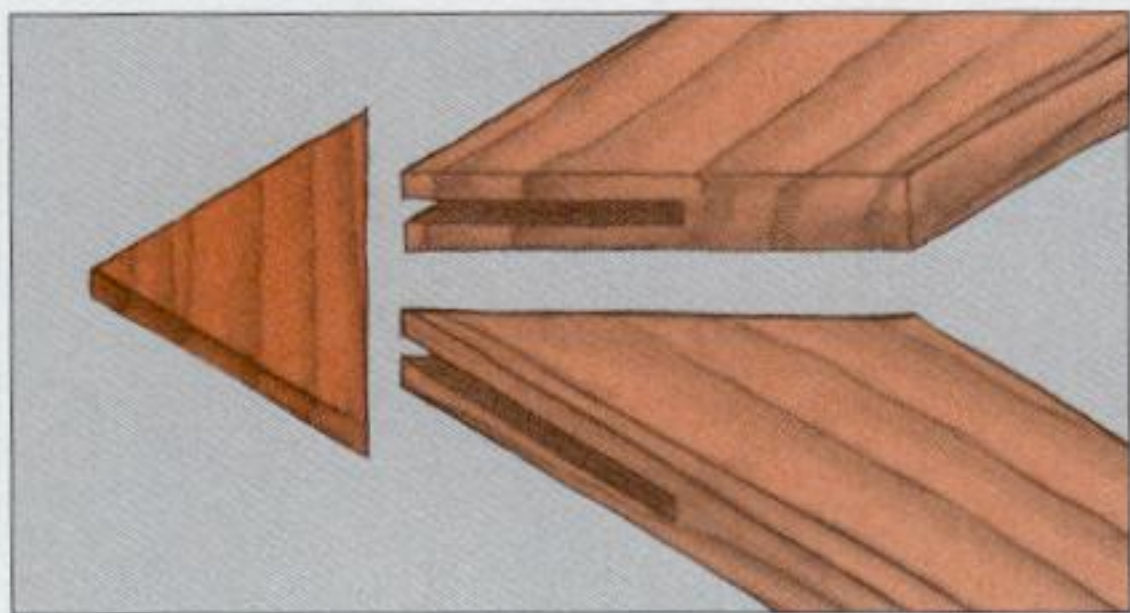
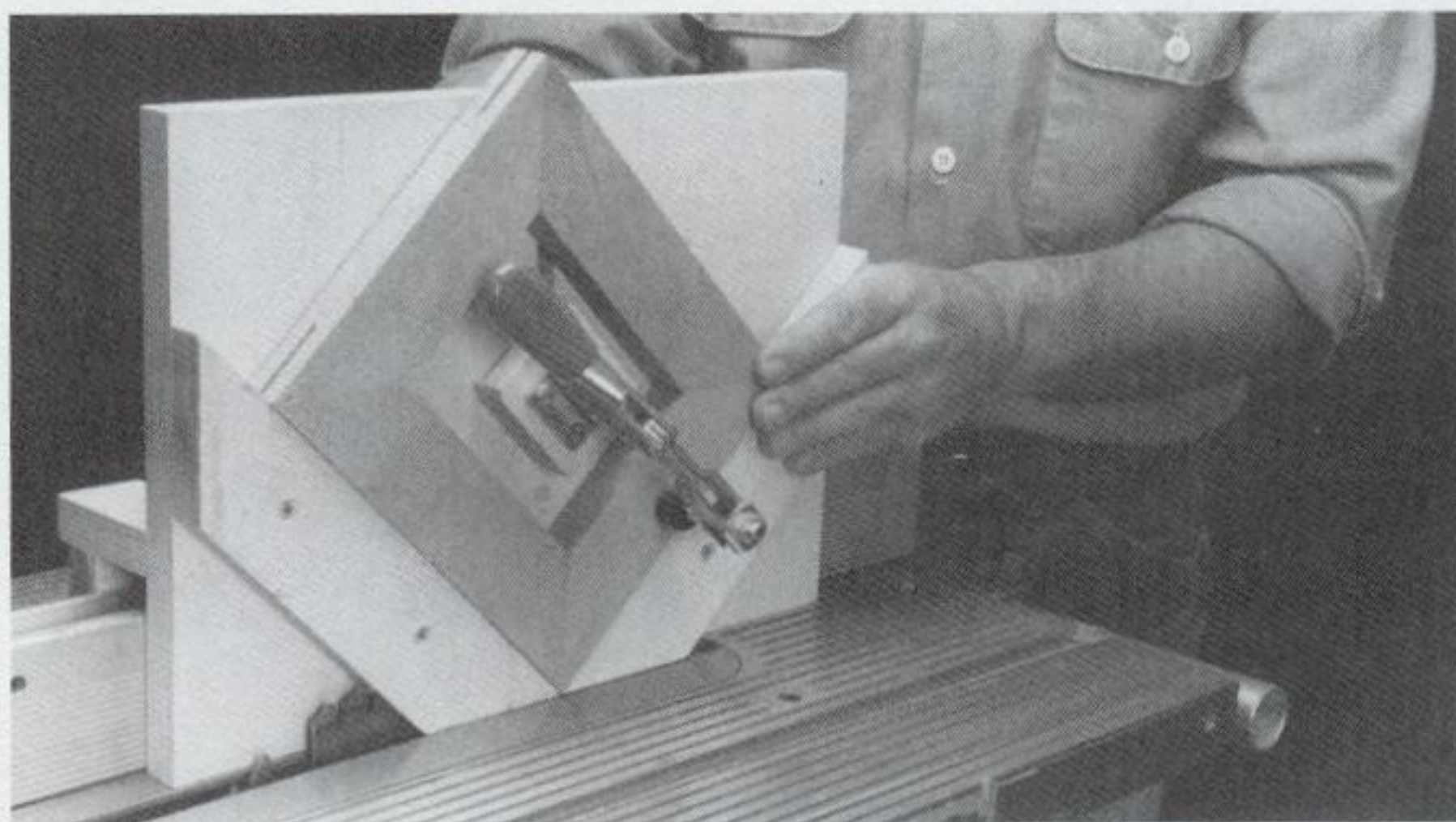

4-17 After cutting the grooves, glue the splines in place. Let the glue dry, then trim the splines and sand them flush with the outside surfaces of the adjoining parts.

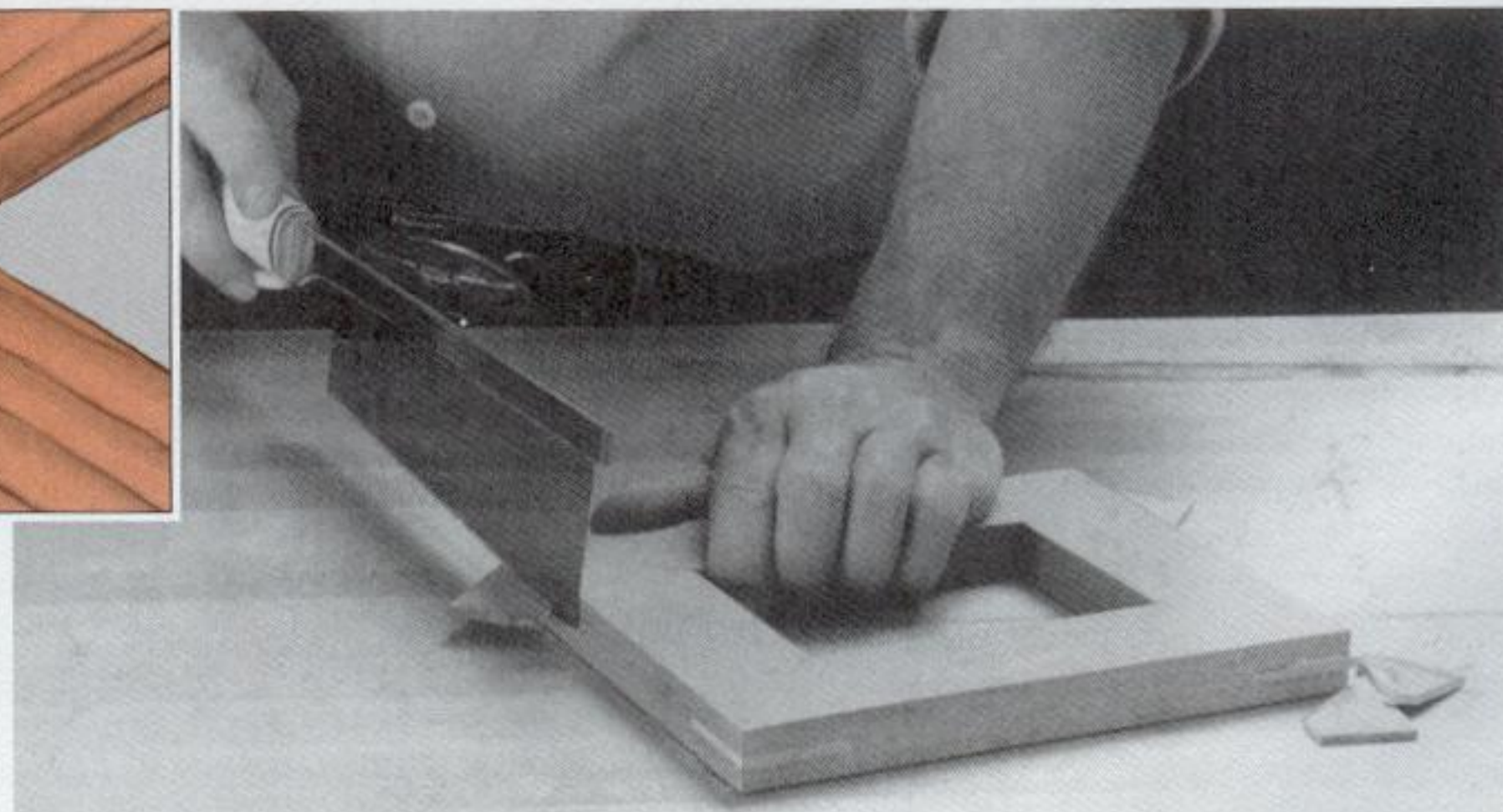

THE VERSATILE MORTISE AND TENON

Although we rarely think of it as such, the mortise-and-tenon joint was one of those technological achievements which, like the wheel or the computer, changed the world forever. The earliest known examples of woodworking were lashed or sewn together. This primitive joinery was inherently weak, and limited the size and complexity of wooden structures. It wasn't until the mortise-and-tenon joint appeared around 3,000 B.C. that people

could take full advantage of wood as a building material. With this new joint, craftsmen made intricate furniture, huge buildings, and wagons and sailing ships capable of crossing great distances.

For all its applications, the mortise-and-tenon joint is deceptively simple. The mortise is just a cavity cut into one of the adjoining members. An end of the remaining member is shaped to make a tenon, which rests in the mortise. If the tenon fits the mortise properly, the

joint will be almost as strong as if the two boards had grown together.

Only in the last 150 years have new materials and joining technology begun to supplant the mortise and tenon. But it still remains the joint of choice among many craftsmen for good, solid wooden framing. Once a tenon is pegged or glued in a mortise, it resists all four types of stress — tension, compression, shear, and racking — better than any other joint.

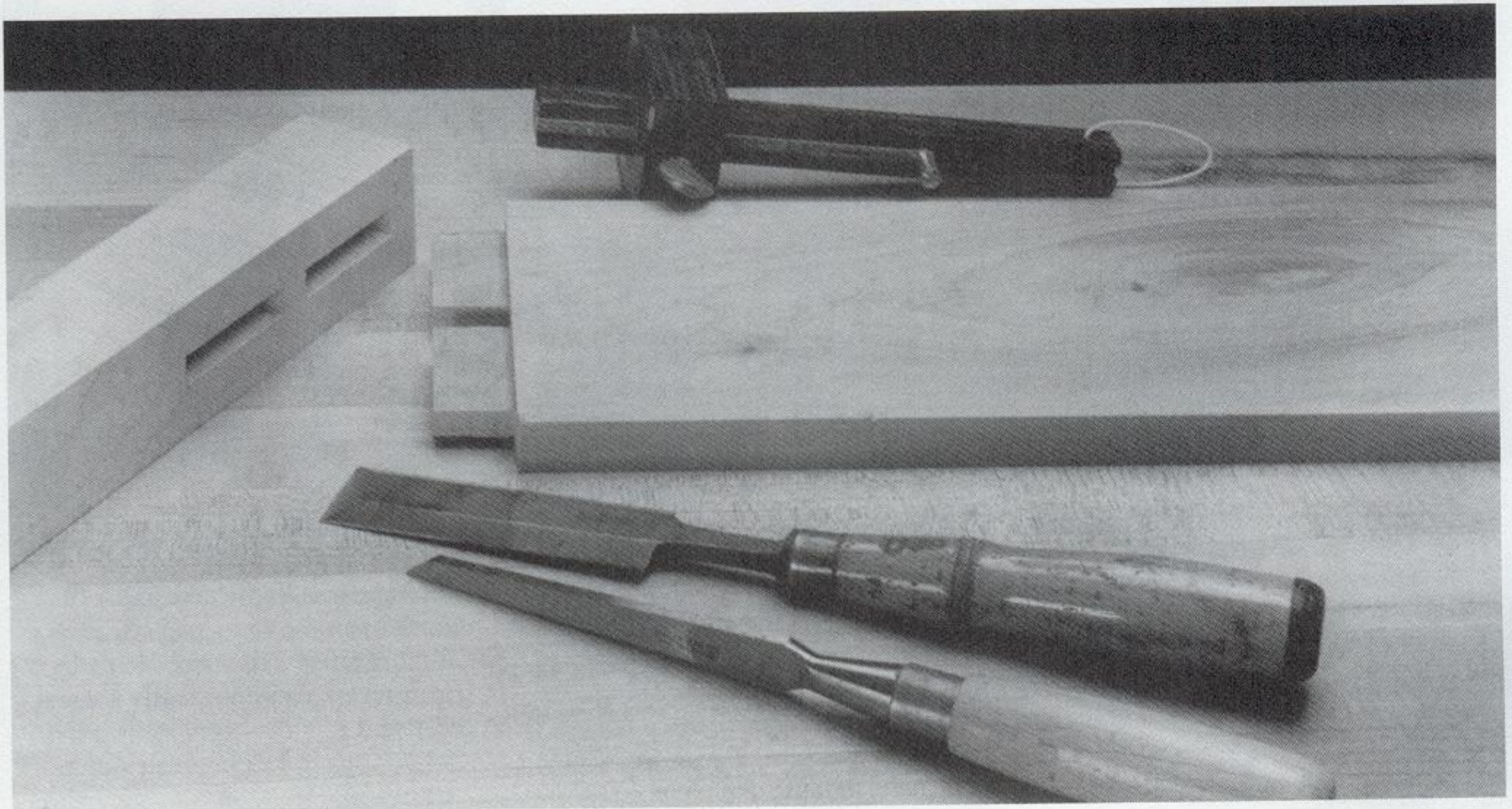

MORTISE AND TENON TIPS

Over nearly five thousand years of woodworking, many different types of mortise-and-tenon joints have evolved. (SEE FIGURE 5-1.) Some of these appear to be quite complex. However, none of them is particularly difficult to make as long as you follow these general guidelines:

- Lay out both the mortise and the tenon with an awl and a marking gauge. It's especially important to scribe the shoulders of the tenon — this will help prevent the cutting tool from tearing the wood grain.
- Make the mortise first, then fit the tenon to it.
- Make sure the wood grain runs *parallel* to the length of the tenon; otherwise, the joint will be weak.
- Make the mating surfaces of the mortise and tenon as smooth as possible for a stronger glue bond.
- Fit the tenon to the mortise so it is snug, but not

too tight. Leave some room for glue, and for wood expansion and contraction.

- A tenon that is to be glued in a mortise should not be more than 3 inches wide or 3 inches long.



FOR YOUR INFORMATION

Woodworkers, such as chairmakers who depend on mortise-and-tenon joints, sometimes keep a dehumidifier in their shop to make it drier than the surrounding environment. Once inside the shop, wood shrinks slightly. When a completed project is returned to normal humidity, the tenons swell in the mortises, making the joints tighter.

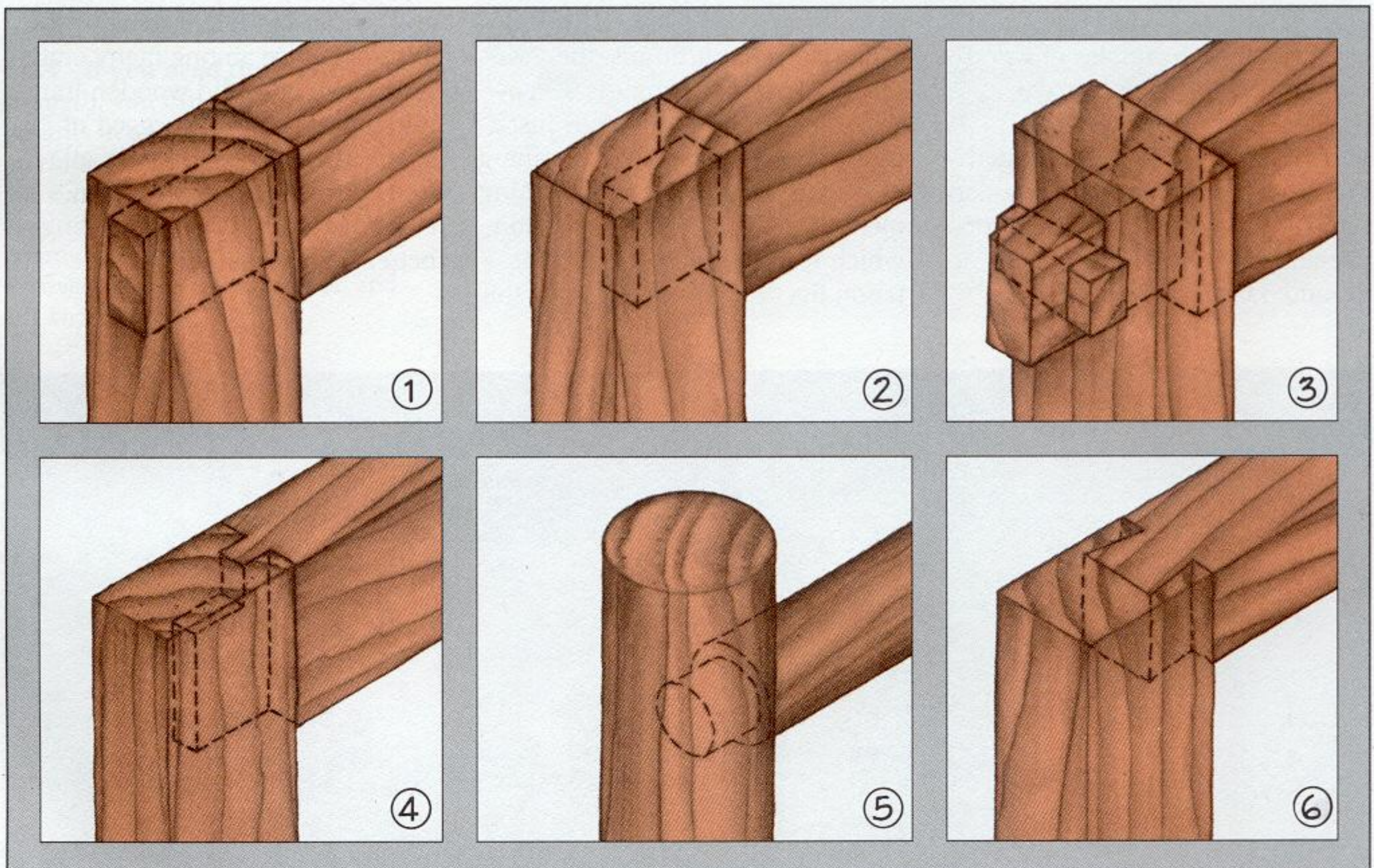

5-1 The mortise and tenon is an extremely versatile joint, and many forms have evolved for various purposes. In the *through mortise and tenon* (1), the tenon passes completely through the mortised member; the end of the tenon is not visible in the

stopped mortise and tenon (2); in the *keyed mortise and tenon* (3), the tenon is held in the mortise by a wedge or “key;” the adjoining parts of the *haunched mortise and tenon* (4) are grooved to hold wooden panels; the *round mortise and tenon* (5) is

used to assemble turned parts; the *dovetail mortise and tenon* (6) is so called because a dovetail-shaped tenon rests in an identically shaped mortise.

MAKING MORTISES

There are many different ways to make a mortise, but we'll concentrate on three of the easiest. Perhaps the simplest of all is to use a drill press. Lay out the mortise, remove as much waste as possible by drilling overlapping holes, then clean up the sides and

corners with a chisel. (SEE FIGURES 5-2 THROUGH 5-4.) If you have less than a dozen mortises to make, this is an excellent method. And because there is little setup time, it's very quick.

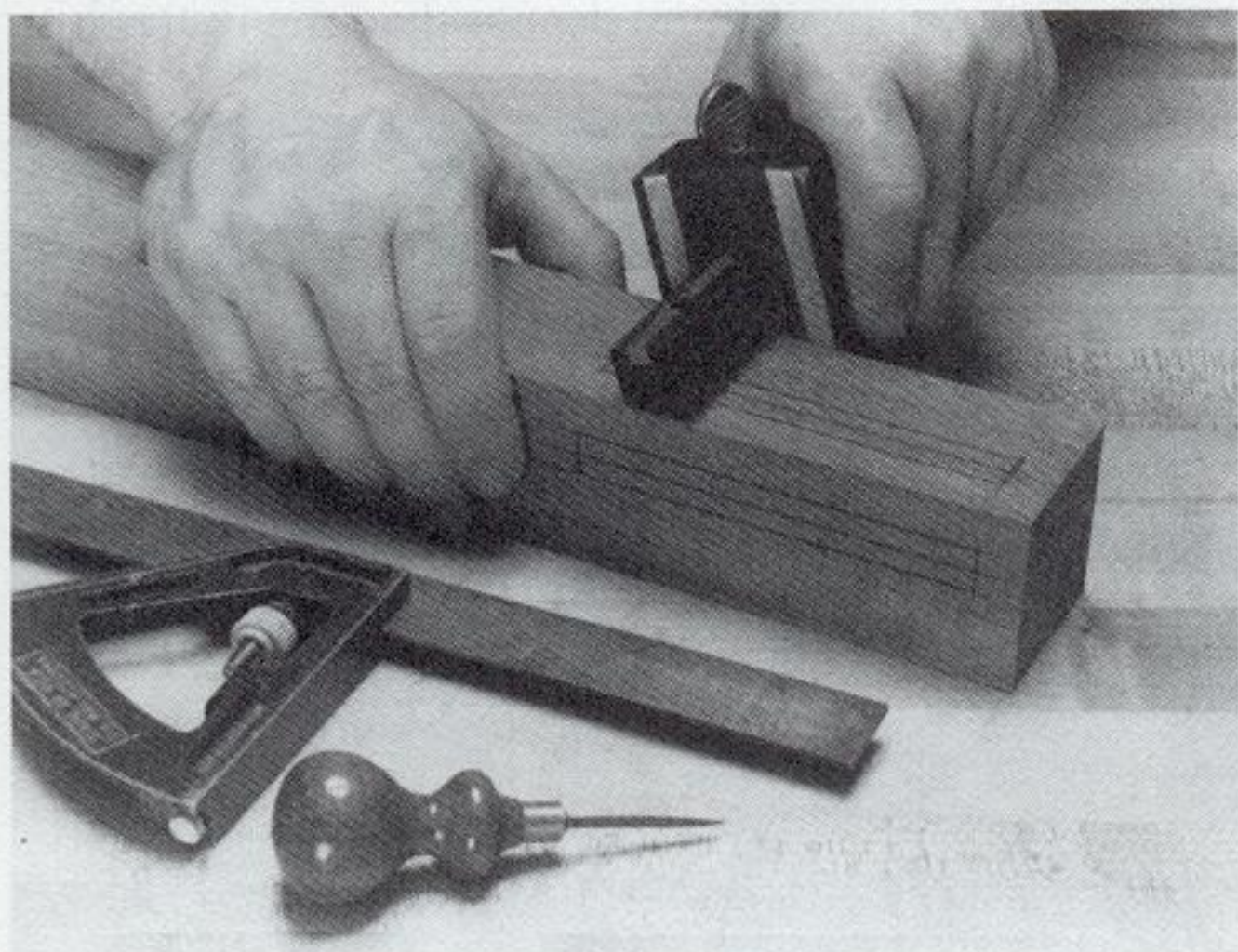

5-2 To make a mortise on a drill press, first lay out the joint on the stock with a marking gauge and an awl. In addition to marking the perimeter of the mortise, scribe a line down the center to help position the drill bit.

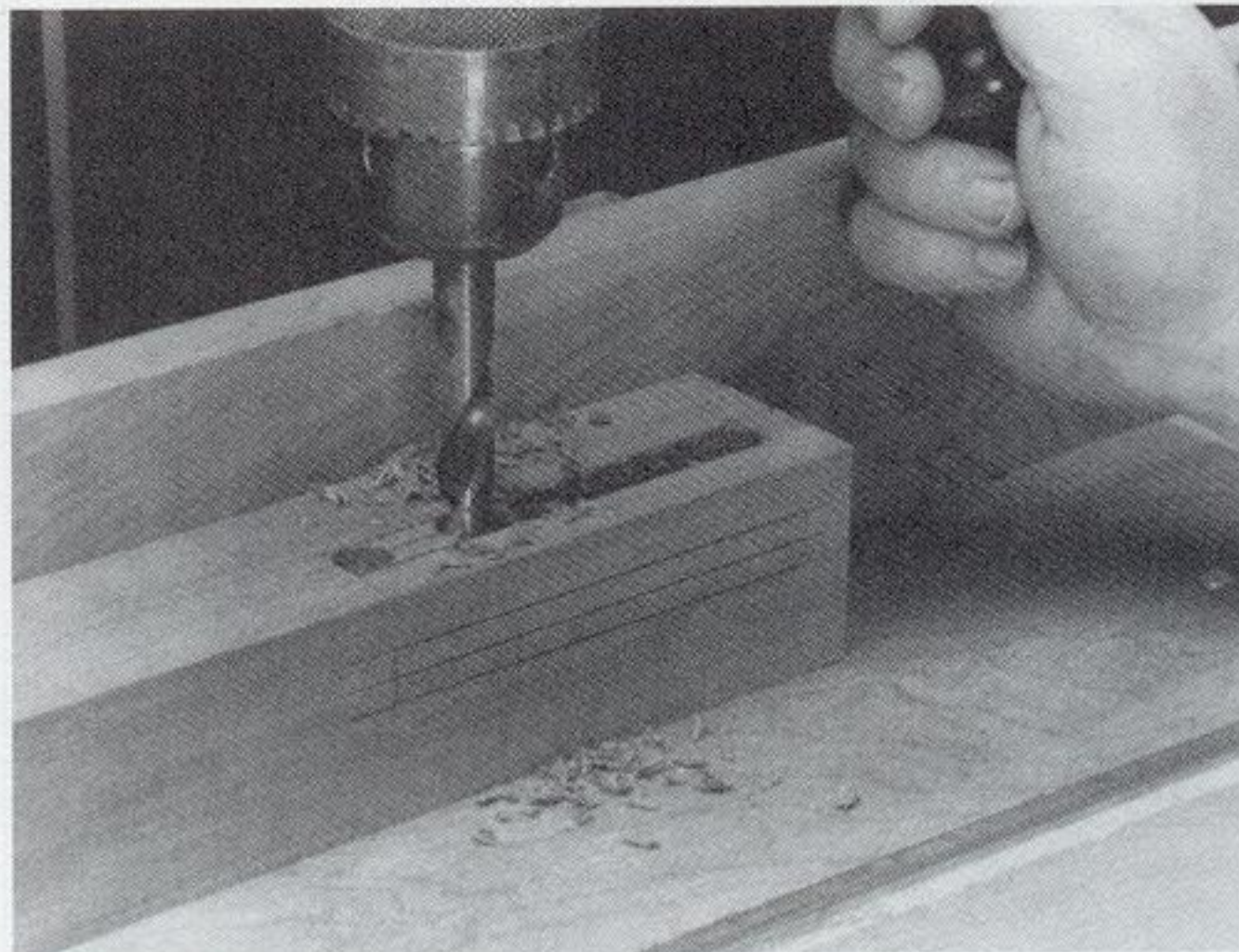

5-3 Select a bit diameter that matches the width of the mortise you want to make. (Some woodworkers prefer to use a bit that is *slightly* smaller.) Mount the bit in the drill press and bore overlapping holes to remove most of the waste from the mortise. Don't space the holes too close; the bit may drift. If you wish, clamp a straightedge to the drill press to guide the stock. This will keep the holes in a perfectly straight line.

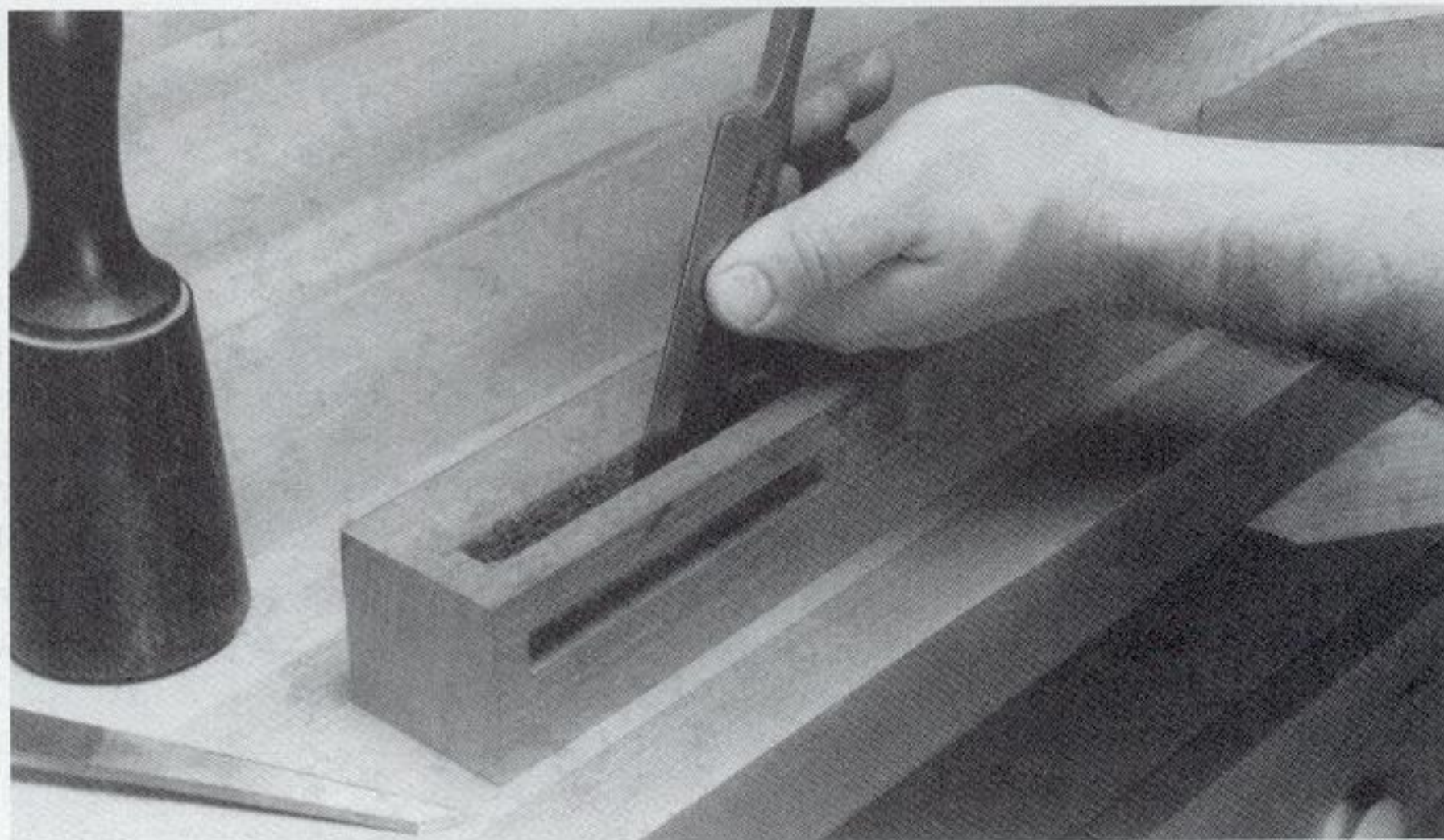

5-4 Remove the remaining waste from the sides and ends of the mortise with chisels. Use an ordinary beveled-edge paring chisel to clean up the sides and — if you have one — a mortising chisel to square the ends.



FOR BEST RESULTS

When cleaning up a mortise, use a *mortising chisel* to square the ends or remove large amounts of stock. Most chisels are designed to be used alternately as a cutting tool and a wedge — you cut down through the grain, then split out the waste. A mortise leaves little room to work in this manner, so a mortising chisel splits as it cuts. The thick blade with its steep bevel pushes the waste to one side as you cut down through the wood. **Note:** Always place the cutting edge of a mortising chisel across the wood grain.

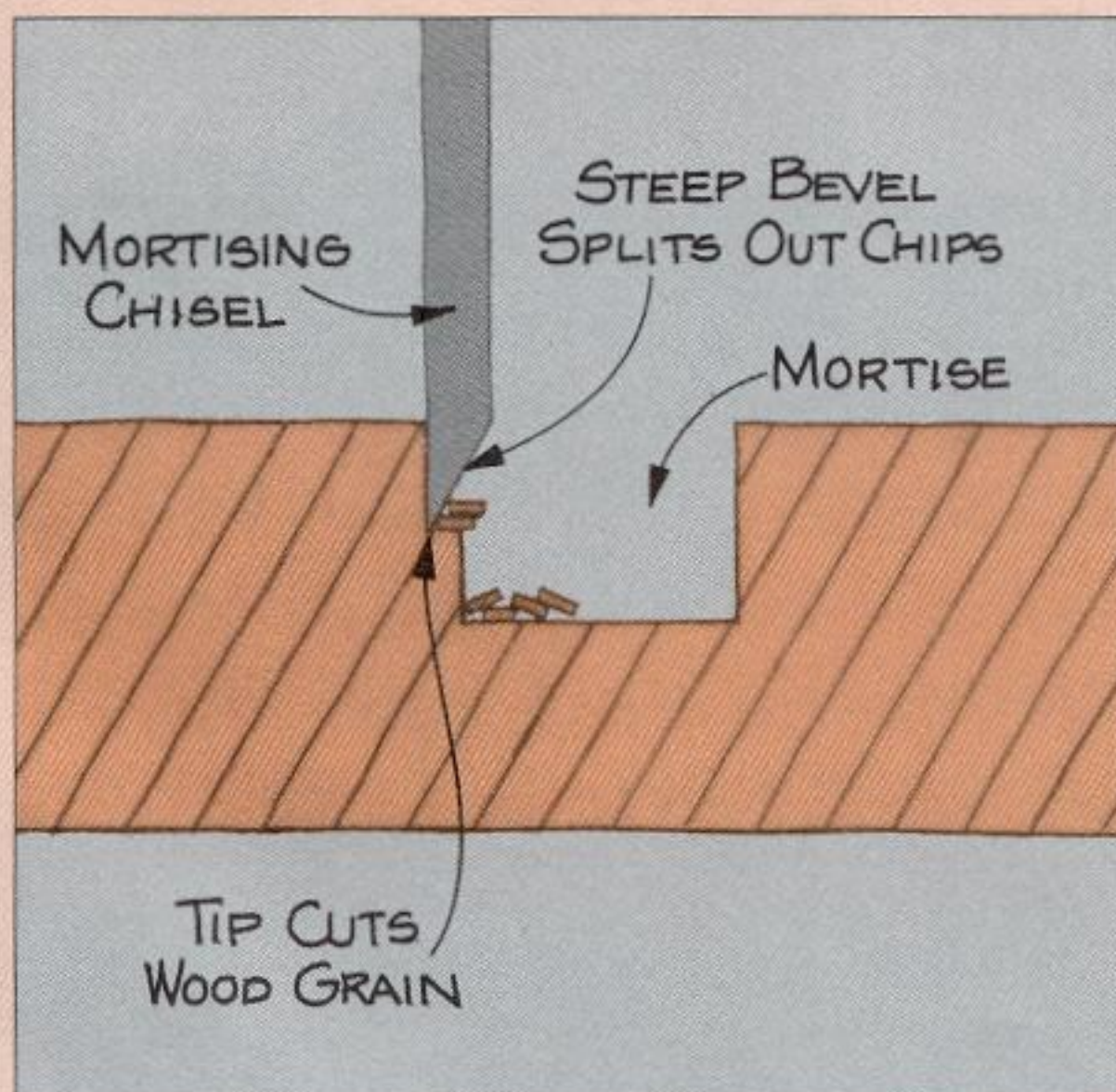
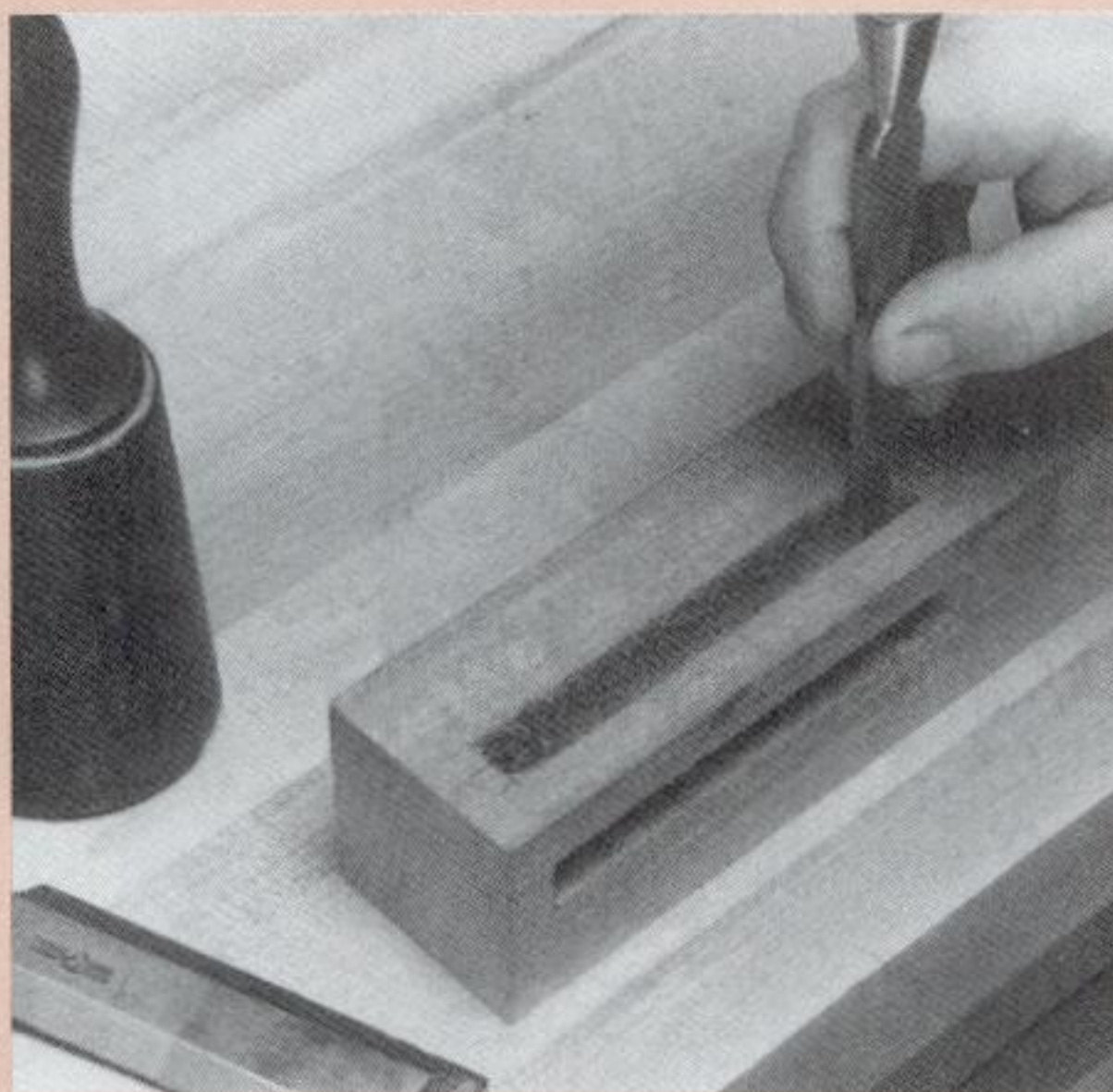

You can also use a hand-held or table-mounted router and a straight bit to cut a mortise. Simply rout a double-blind dado in the stock, then square the blind ends with a chisel. (SEE FIGURES 5-5 THROUGH 5-10.) This method requires more setup time, but saves cutting time, particularly if you have a lot of mortises to make. The drawback is that you can only make relatively shallow mortises, no deeper than the router bit will reach.

When routing a mortise, make the recess in several passes. Remove just $\frac{1}{8}$ to $\frac{1}{4}$ inch of stock with each pass — remember that routers and router bits aren't designed to remove large amounts of stock all at once. If you have a lot of mortises to rout, adjust the router to cut no more than $\frac{1}{4}$ inch deep. Cut all the mortises in all the workpieces to this depth. Increase the depth of cut and rout all the mortises again. Continue until you have routed the mortises as deep as you want them.

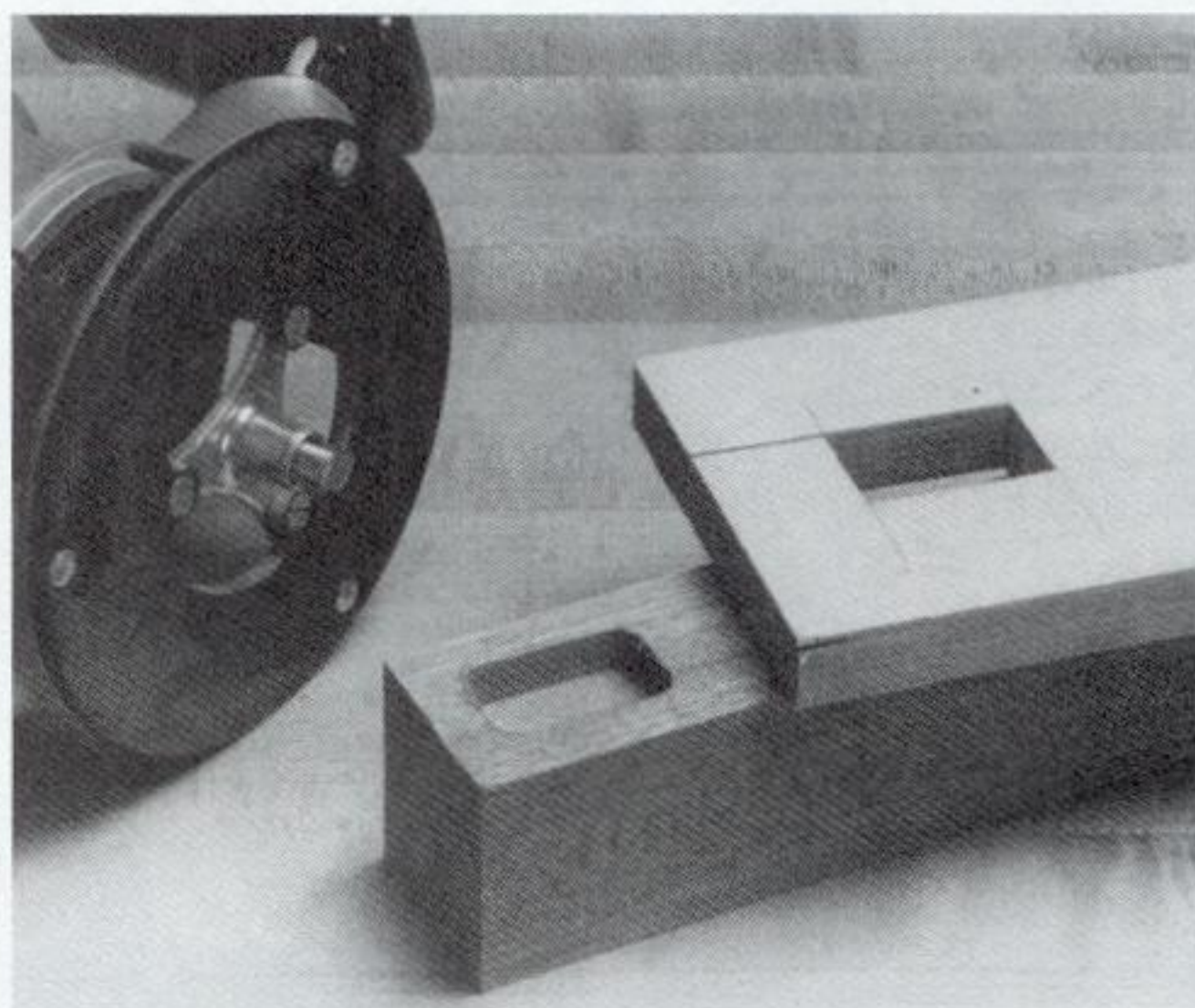

5-5 To rout a mortise with a hand-held router, make a frame to guide the router. Clamp the frame to the workpiece and rout the mortise, keeping the base of the router inside the frame. The inside dimensions of the frame will control the length and width of the mortise. **Note:** If you have one, use a plunge router when performing this operation. Otherwise, you may want to drill a stopped hole that's a little larger than the router bit into the middle of the mortise. This will provide a place to start routing.



TRY THIS TRICK

If you wish, use a mortising fence to make multiple mortises. This jig has adjustable stops at both ends to automatically start and stop mortise cuts, and can

be used on both a drill press and a router table. Plans and instructions for making this “Mortising Fence” are on page 67.

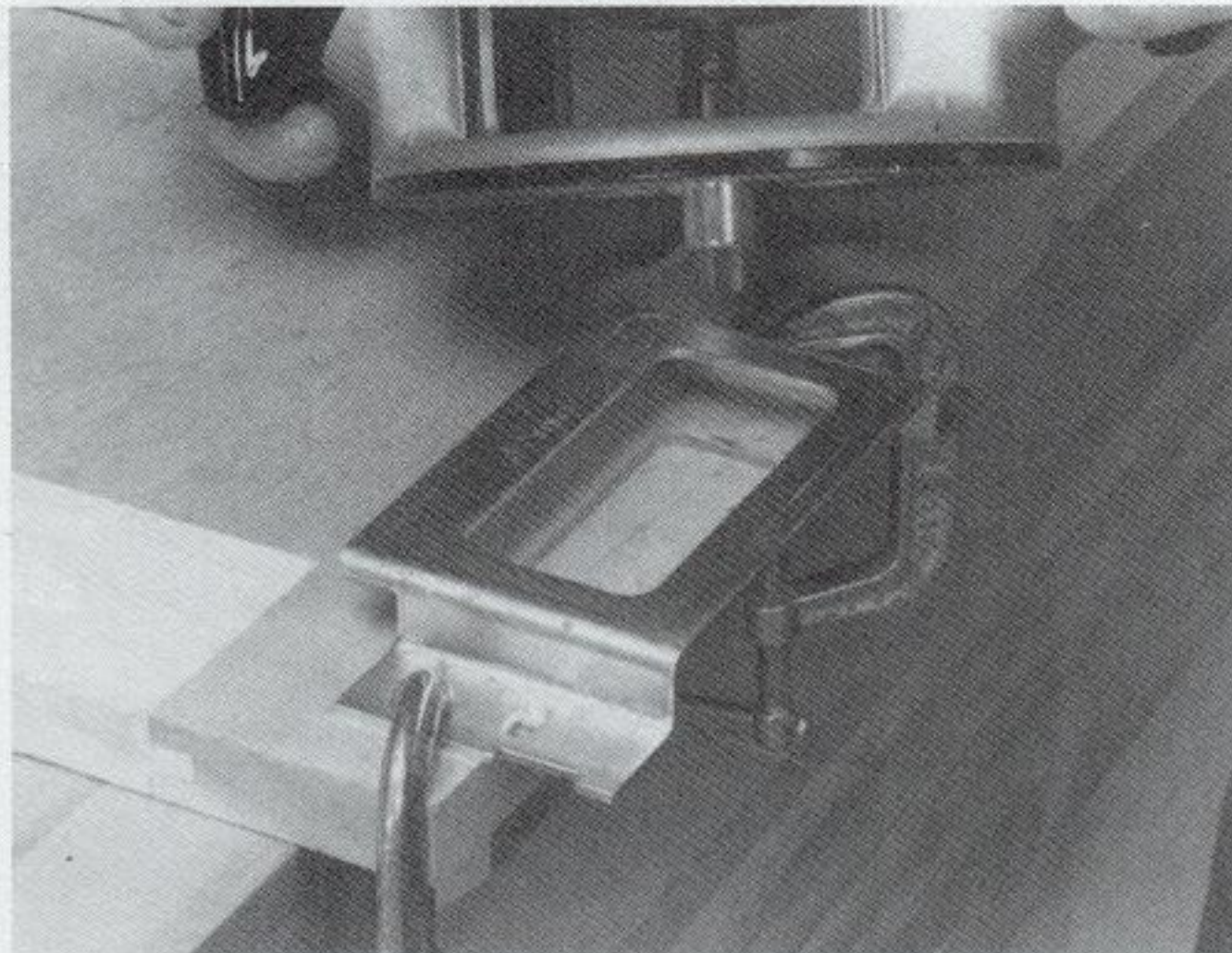

5-6 You can also use a guide collar and a template to make a mortise with a hand-held router. Mount the guide collar on the router sole with the bit protruding through the center. Clamp the template to the workpiece and rout the mortise, following the inside edges of the template with the collar. This setup is especially useful for routing small mortises.

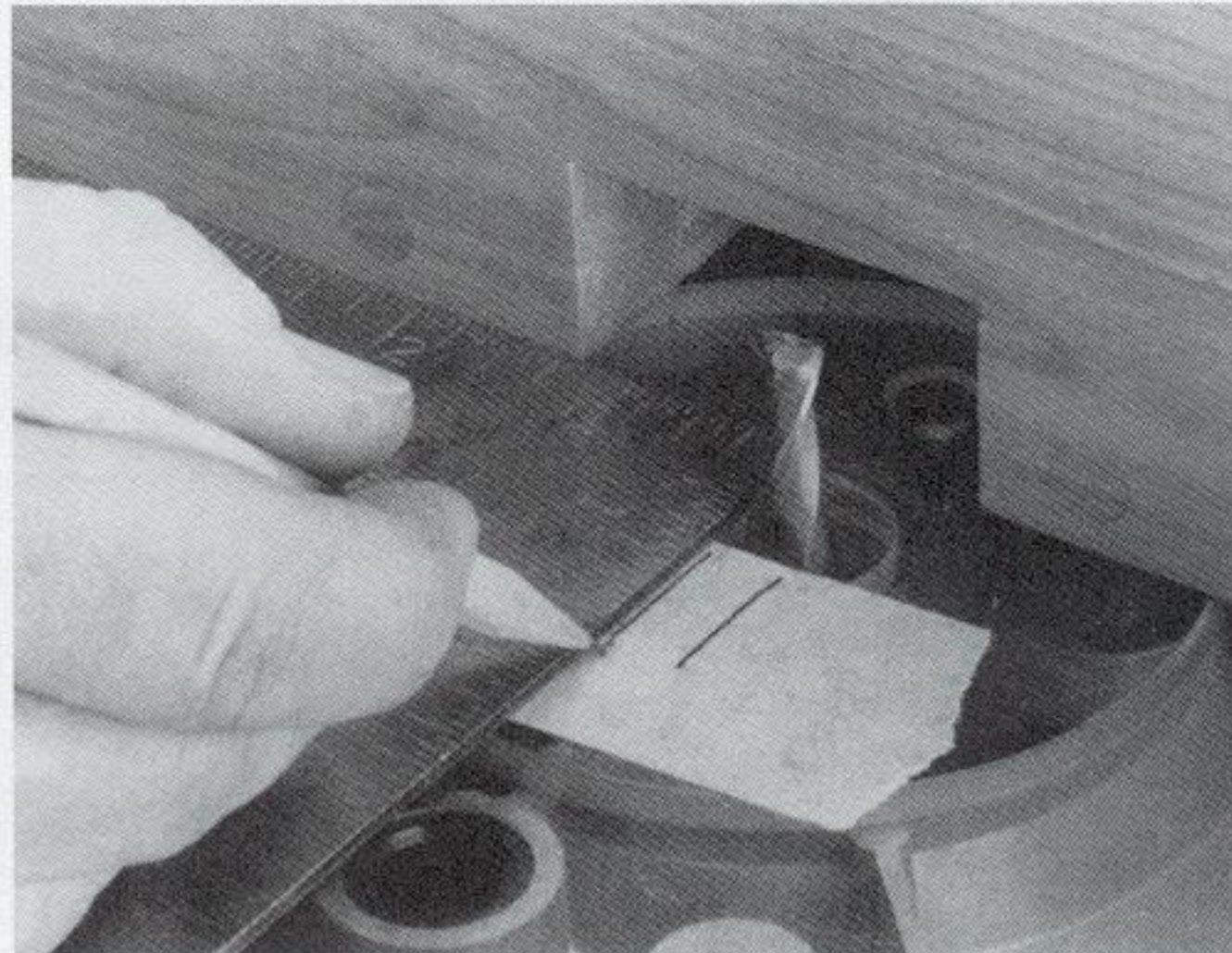

5-7 When routing a mortise on a table-mounted router, it's difficult to know where to start and stop since you can't see the cut as it progresses. To remedy this situation, make several alignment marks where they will be visible on both the machine and the workpiece. First, put a piece of tape on the fence or on the work surface of the router table. Using a small square, mark the diameter of the bit on the tape.

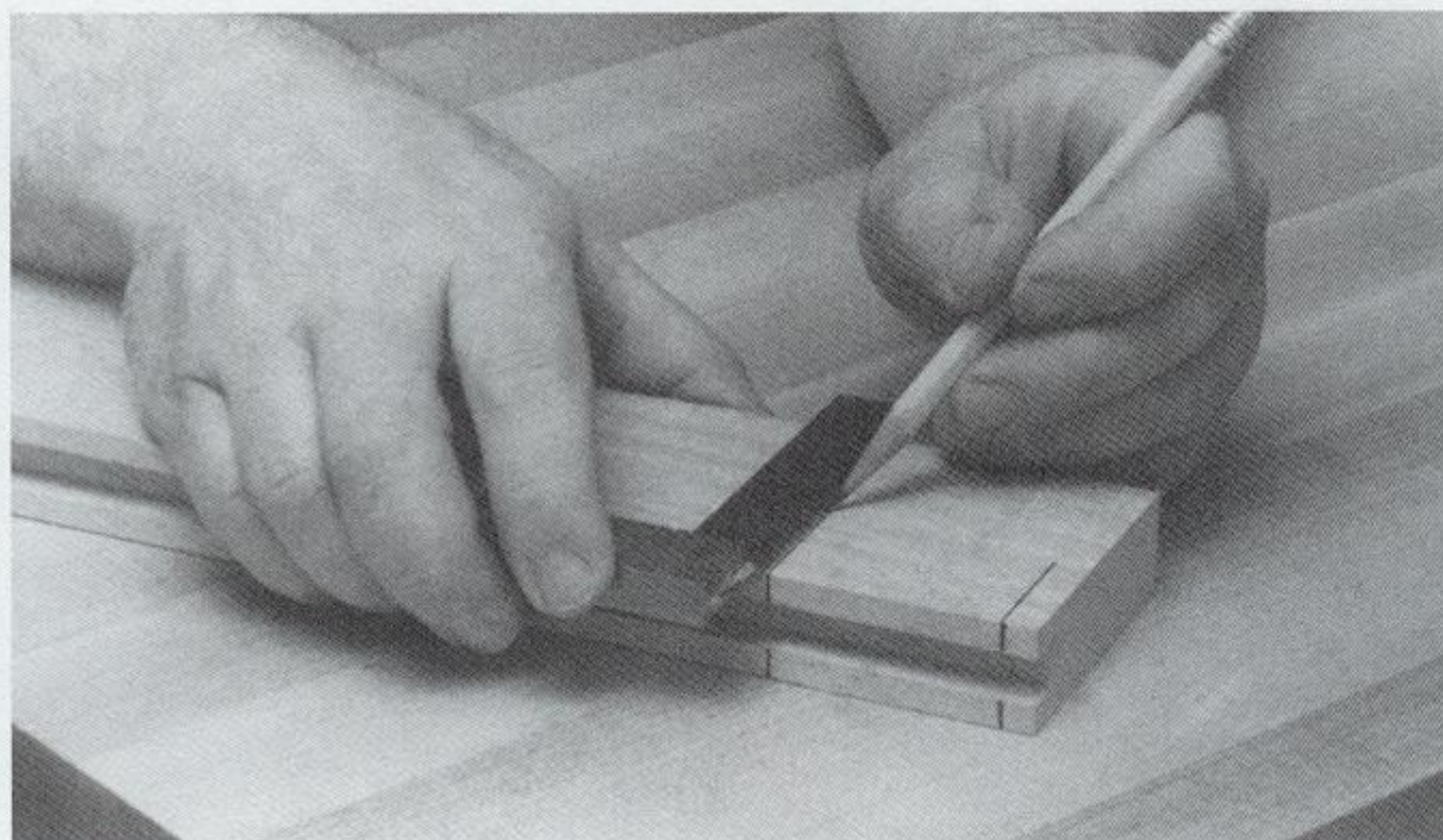

5-8 Next, use the square to transfer the layout lines that mark the *length* of the mortise to another surface on the workpiece. This surface must be clearly visible when you cut.

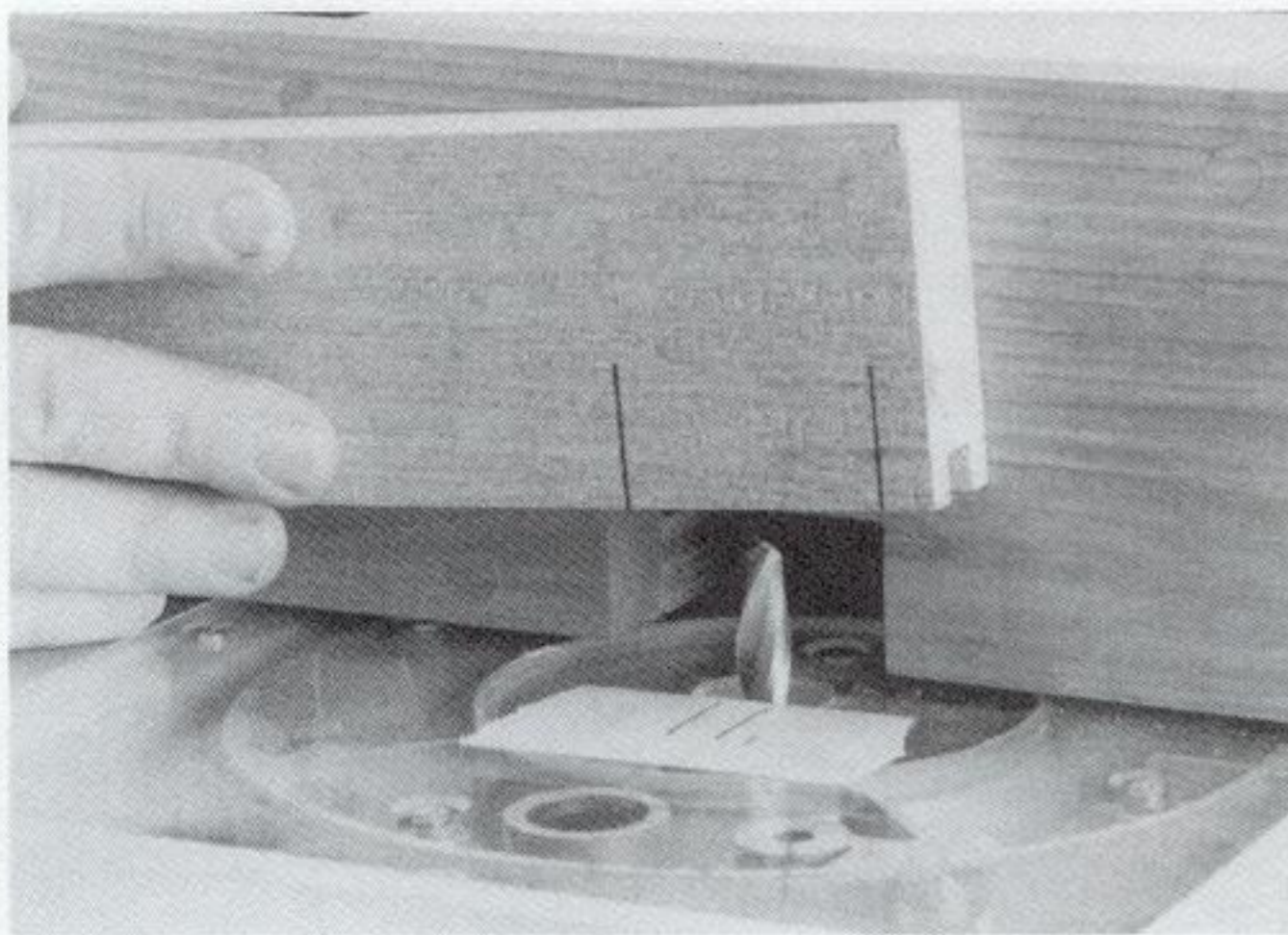

5-9 Select a router bit that's the same diameter as the width of the mortise you want to make. Mount it in the router and adjust the depth of cut to cut no more than $\frac{1}{8}$ – $\frac{1}{4}$ inch at one time. Secure a fence or straightedge to the router table to guide the workpiece. Hold the workpiece firmly against the fence with the area to be mortised above the bit. (If possible, let one end of the workpiece rest on an edge of the table.) Turn the router on and carefully lower the workpiece onto the bit.

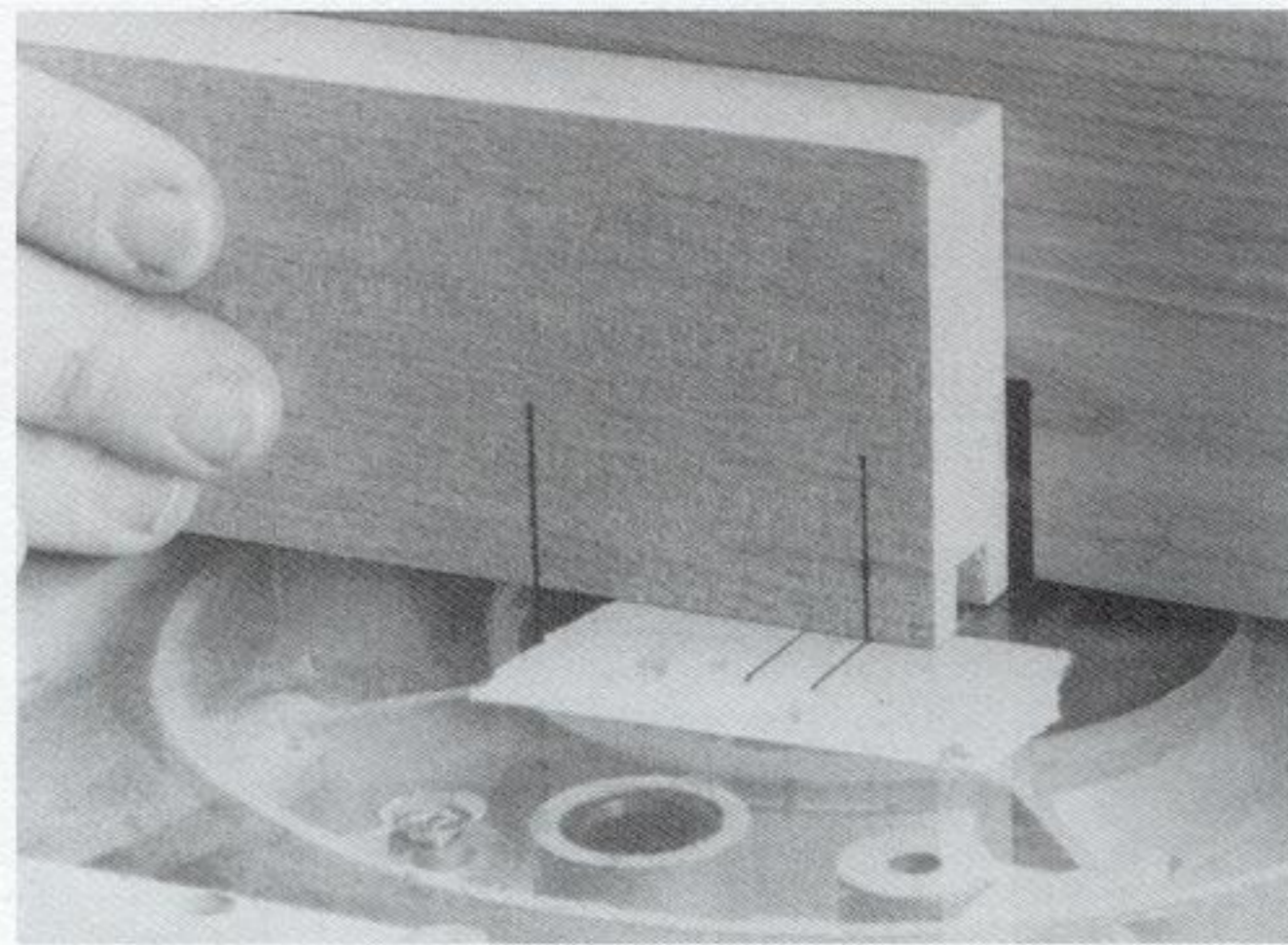

5-10 Feed the work to the right until the left-hand mark on the workpiece lines up with the left-hand mark on the router table. Then feed it back to the left until the right-hand marks line up. As you're cutting, keep the stock firmly against the fence or straightedge. Finally, turn off the router and let it come to a complete stop before removing the workpiece. Note: A foot-operated switch is very handy for this operation.

Finally, you can use a mortiser or a mortising attachment to make a mortise. As mentioned previously, a mortiser makes a *square* hole. Drill a series of overlapping square holes to form the rectangular mortise. (SEE FIGURES 5-11 AND 5-12.) Of the three methods, this requires the most setup time, particularly if you have to mount the mortising attachment on a drill press.

But it eliminates all hand work; you don't have to clean up the mortises with a chisel. If you make a lot of mortises, this will save time. The drawback is that a mortiser is a finicky tool that must be set up and operated with special care. Refer to "Using a Mortiser" on page 69 for more information.

5-11 Use a mortising attachment on a drill press to bore a row of overlapping *square* holes, in much the same way you would bore overlapping round holes. These holes will form a mortise without your having to clean up the sides or square the ends.

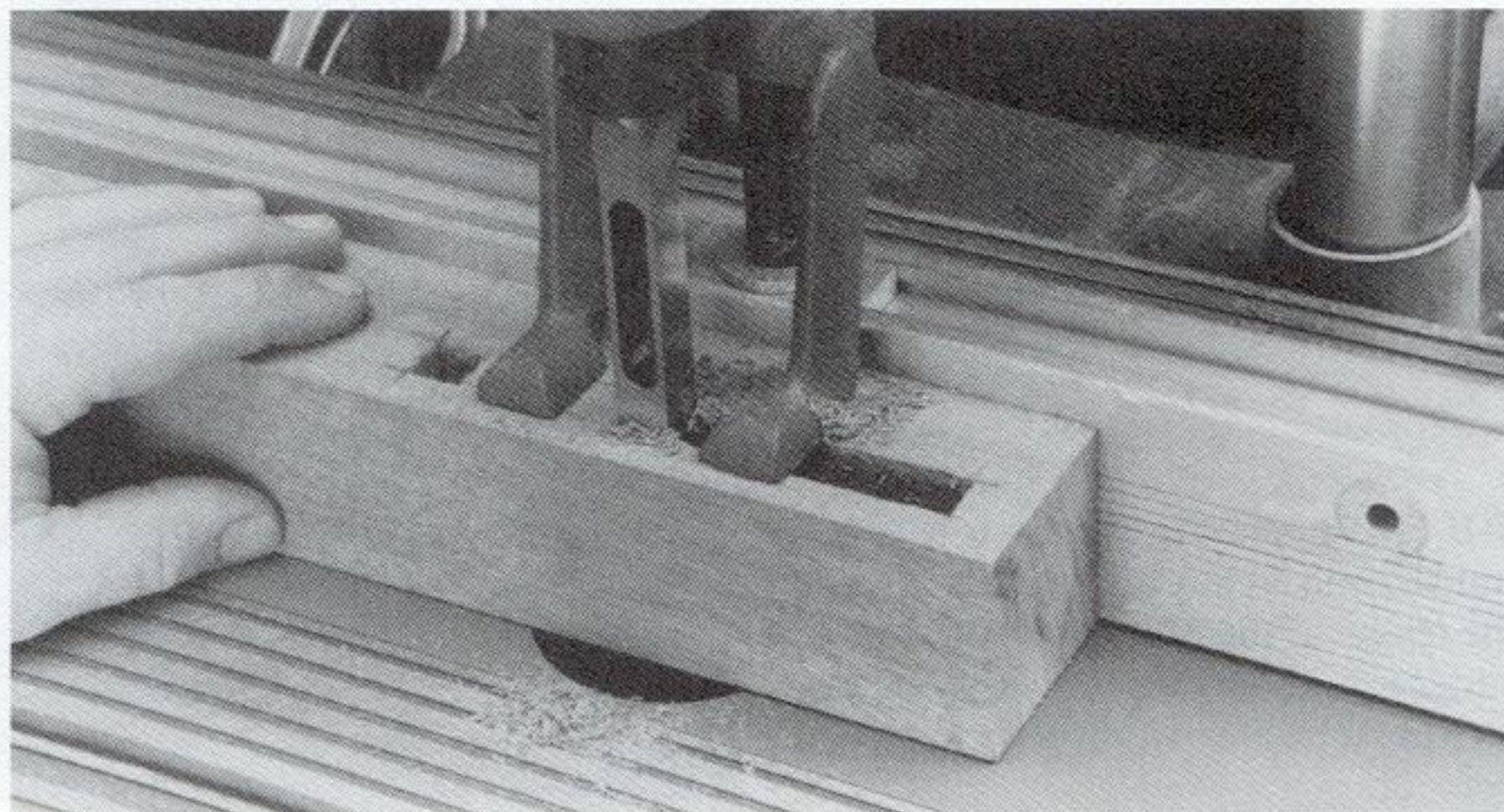

USING A MORTISER

A mortiser drills a square hole by combining the action of a chisel and a drill bit. A square, hollow chisel attaches to the drill press quill and moves up and down. A bit mounts in the chuck and spins inside the chisel. As you feed both cutting tools

into the wood, the bit drills a round hole and the chisel trims it square. The edges of the chisel are beveled to direct the chips into the bit, which carries them up and out of the way.

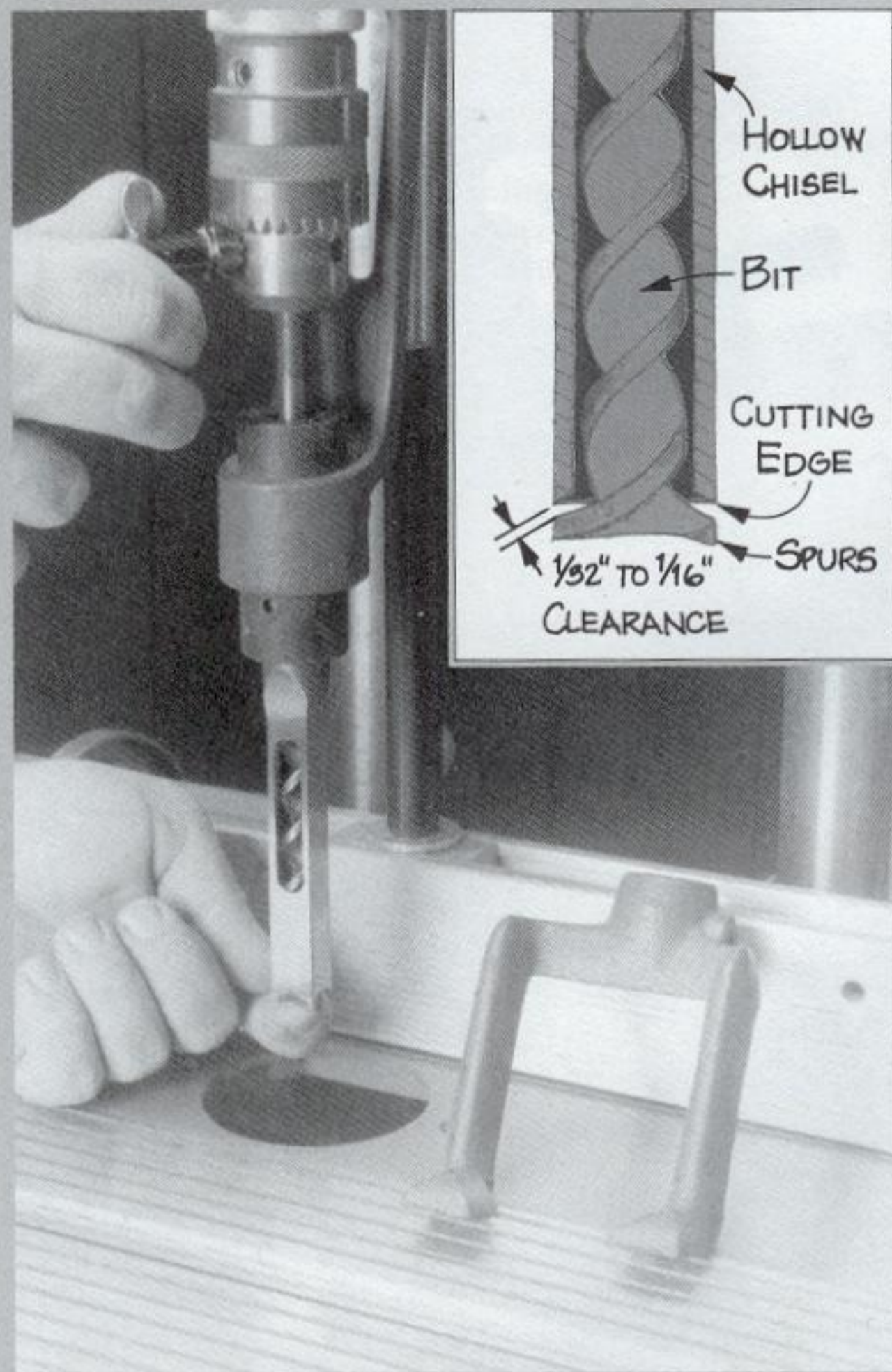
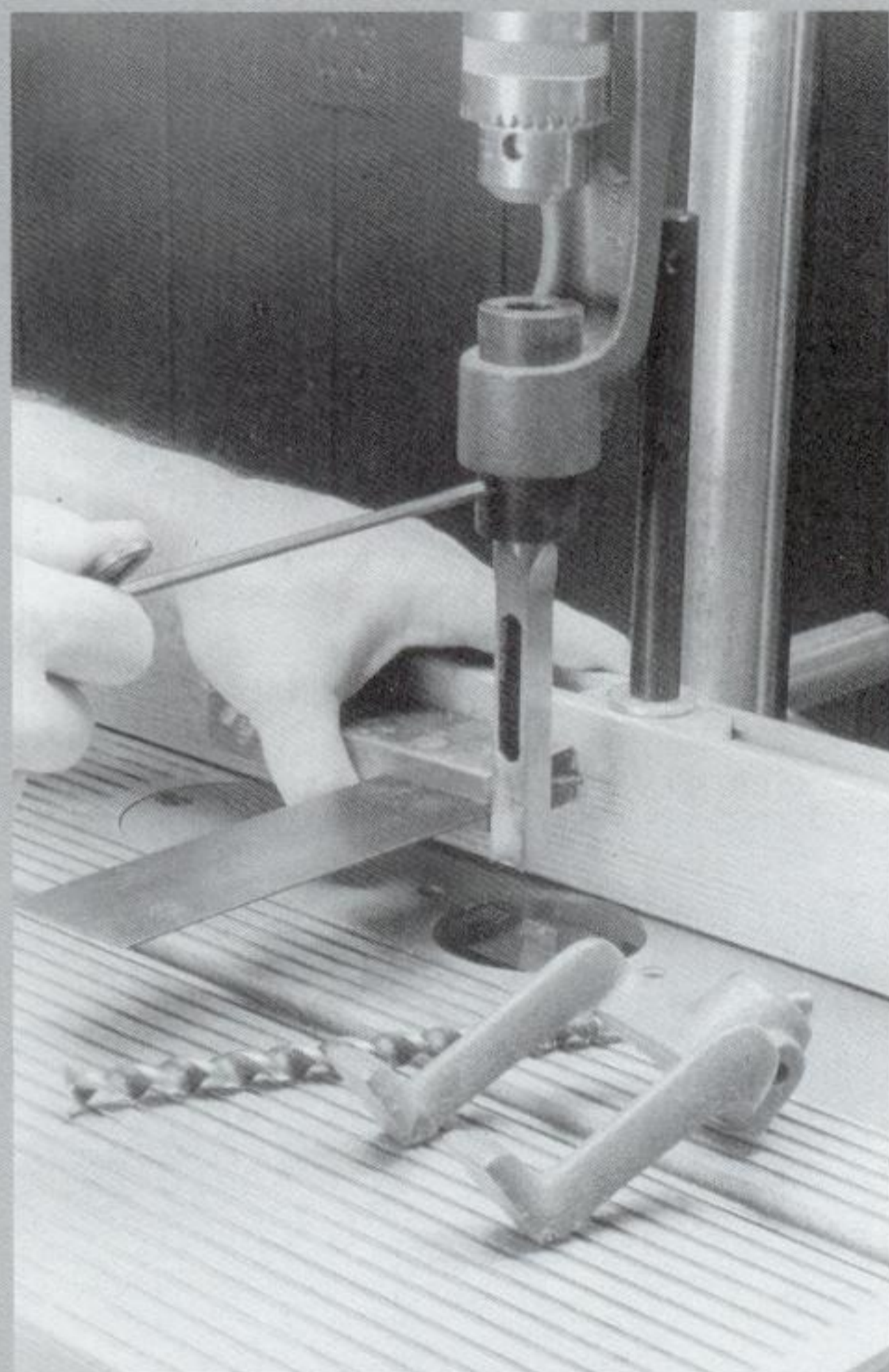

1 In setting up a mortiser, employ a fence to guide the workpiece. Use a small square to position the chisel so the front and back surfaces are parallel to the fence. If they aren't, the sides of the mortise won't be straight. Adjust the mortiser's hold-down to keep the stock flat on the table. Otherwise, you'll find it difficult to retract the bit.

2 Adjust the clearance between the spurs on the bit and the end of the chisel to no less than $\frac{1}{32}$ inch and no more than $\frac{1}{16}$ inch. **This is very important!** If the clearance is too little, the bit will rub on the chisel. The resulting friction will heat the chisel and the bit, ruining both. If it's too large, the spurs won't break up the wood chips, and they will clog the chisel.

USING A MORTISER — CONTINUED

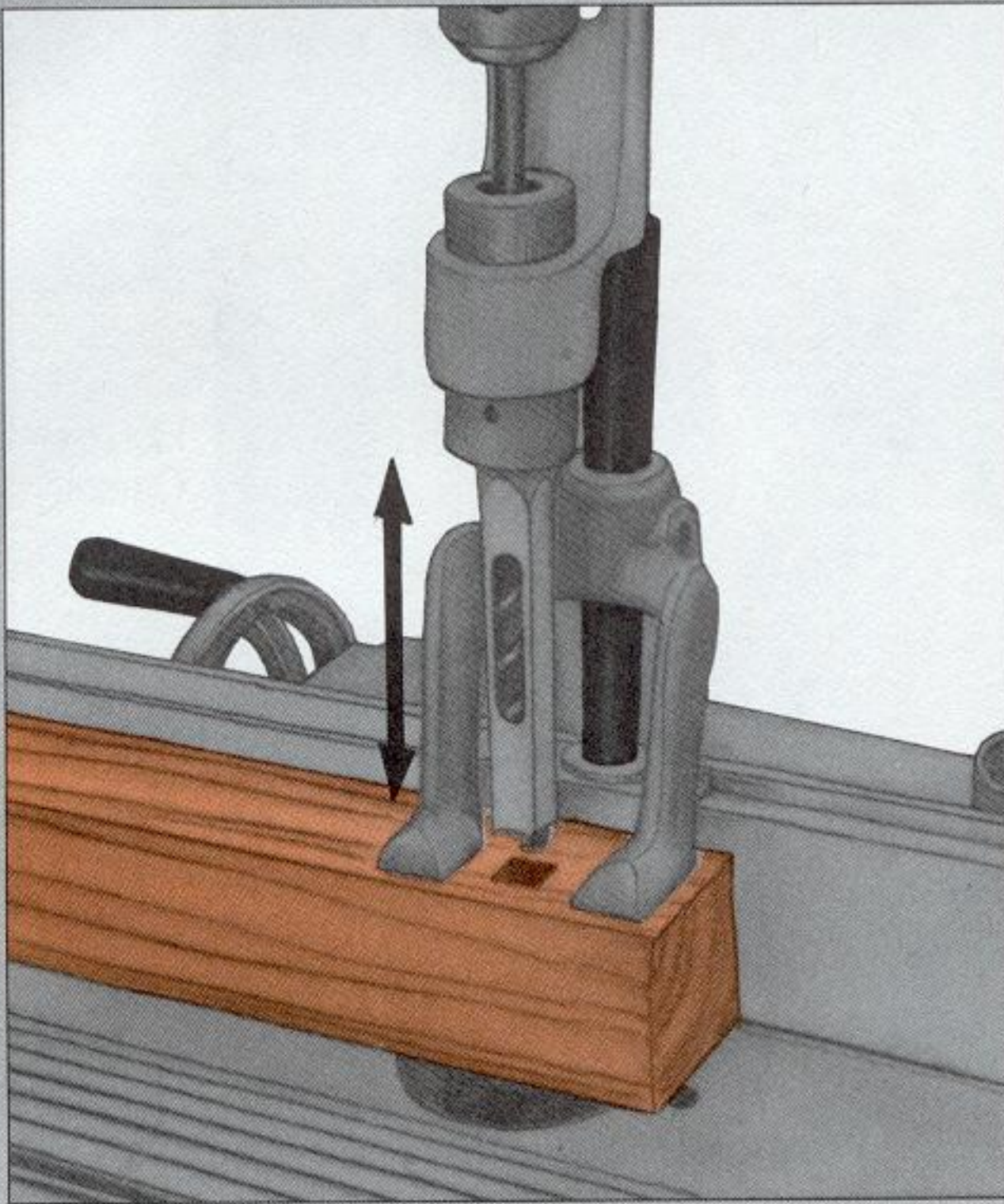

3 When drilling a square hole, feed the chisel slowly with a firm pressure. Give the tool plenty of time to clear the chips. It also helps to retract the chisel often. Plunge the chisel into the wood, hold the pressure for a few seconds, retract the chisel, and repeat. (This technique is especially useful when mortising hardwoods.) If you have to use excessive pressure to drill a hole, there is something wrong with your setup — most probably, the clearance between the bit and the chisel is incorrect or the cutting tools are dull.

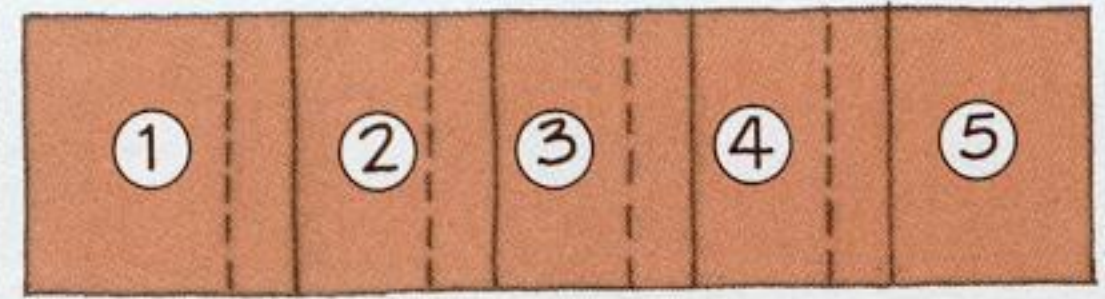

WRONG

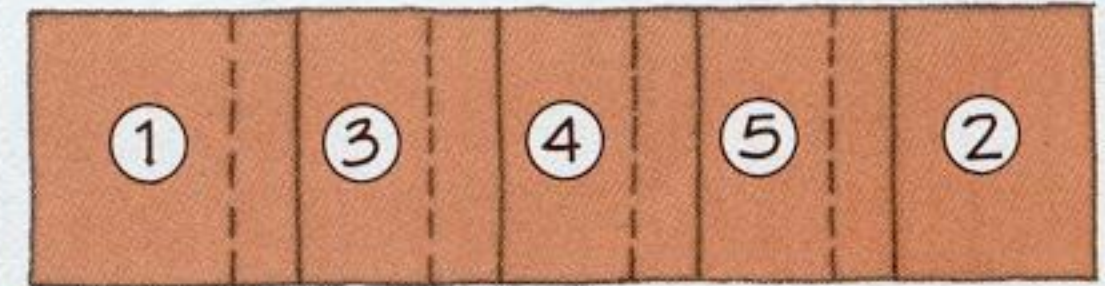

RIGHT

4 When drilling a row of overlapping square holes, you must make the cuts in the proper sequence. Drill the ends of the mortise first, then go back and remove the waste between them. Ideally, the overlapping portion of the holes should be no more than one-quarter the width of the chisel — otherwise, the chisel may drift in the cut.

MAKING AND FITTING TENONS

There are also many ways to make a tenon. Again, here are three of the easiest.

Many woodworkers prefer to make tenons on a table saw with an ordinary blade. First, cut the shoulders of the tenon, using a miter gauge to guide

the workpiece. Then cut the cheeks, using a tenoning jig. (For instructions and plans on how to make this fixture, see the “Tenoning Jig” on page 72.) Test fit the tenon to its mortise and adjust the setup as needed.

(SEE FIGURES 5-13 AND 5-14.)

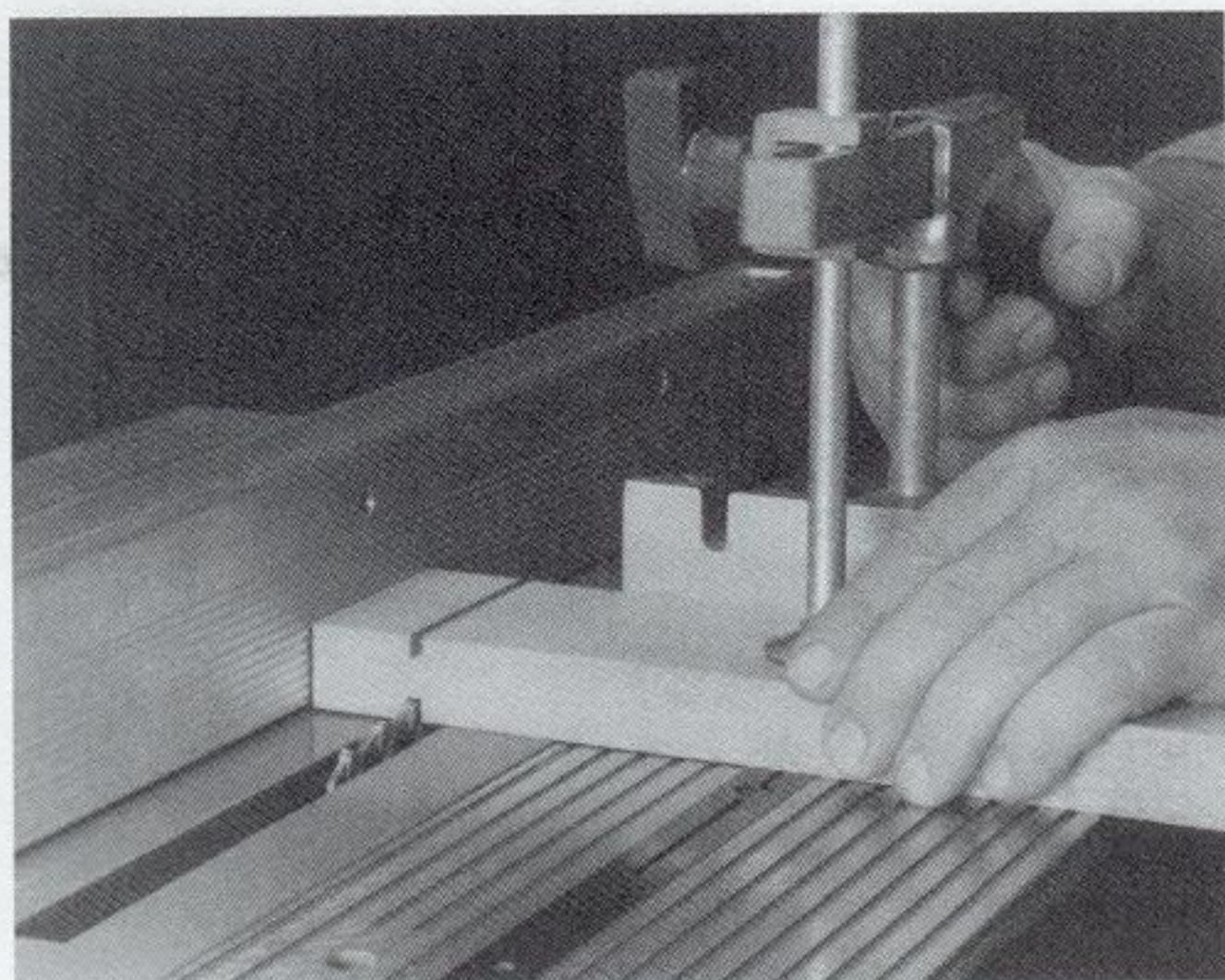

5-13 To cut a tenon with an ordinary table saw blade, first cut the shoulders. Guide the stock with a miter gauge. If you wish, use the fence to position the stock on the gauge.

You can also make a tenon with a dado cutter. The advantage to using this accessory is that you can cut both a shoulder and a cheek in one pass. You also have a choice of using either the tenoning jig or the

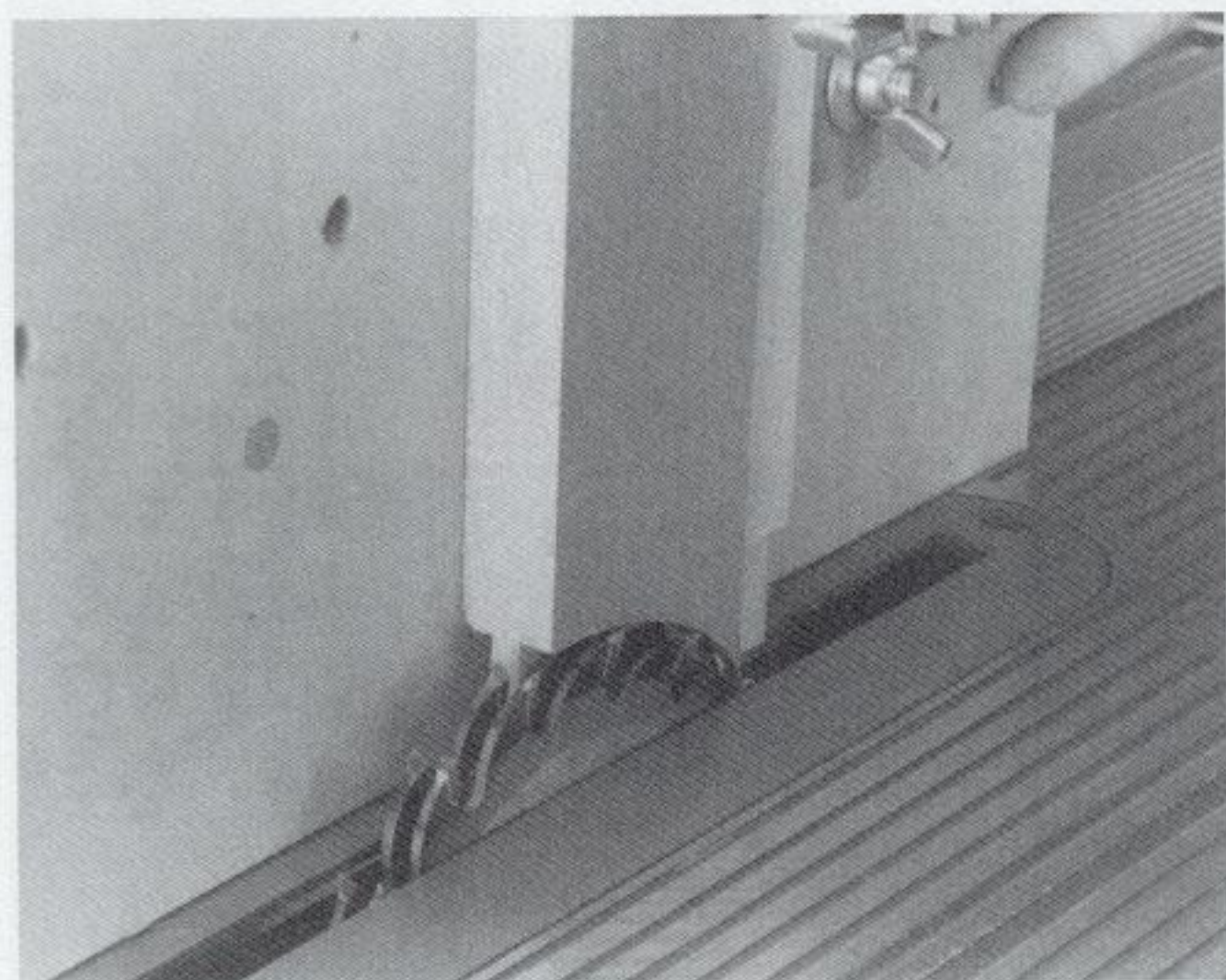

5-15 To cut a tenon with a dado cutter, mount the workpiece in a tenoning jig. Back up the workpiece with a scrap board to prevent the cutter from tearing the wood grain when it exits the workpiece. Then guide the jig along the fence, past the cutter.

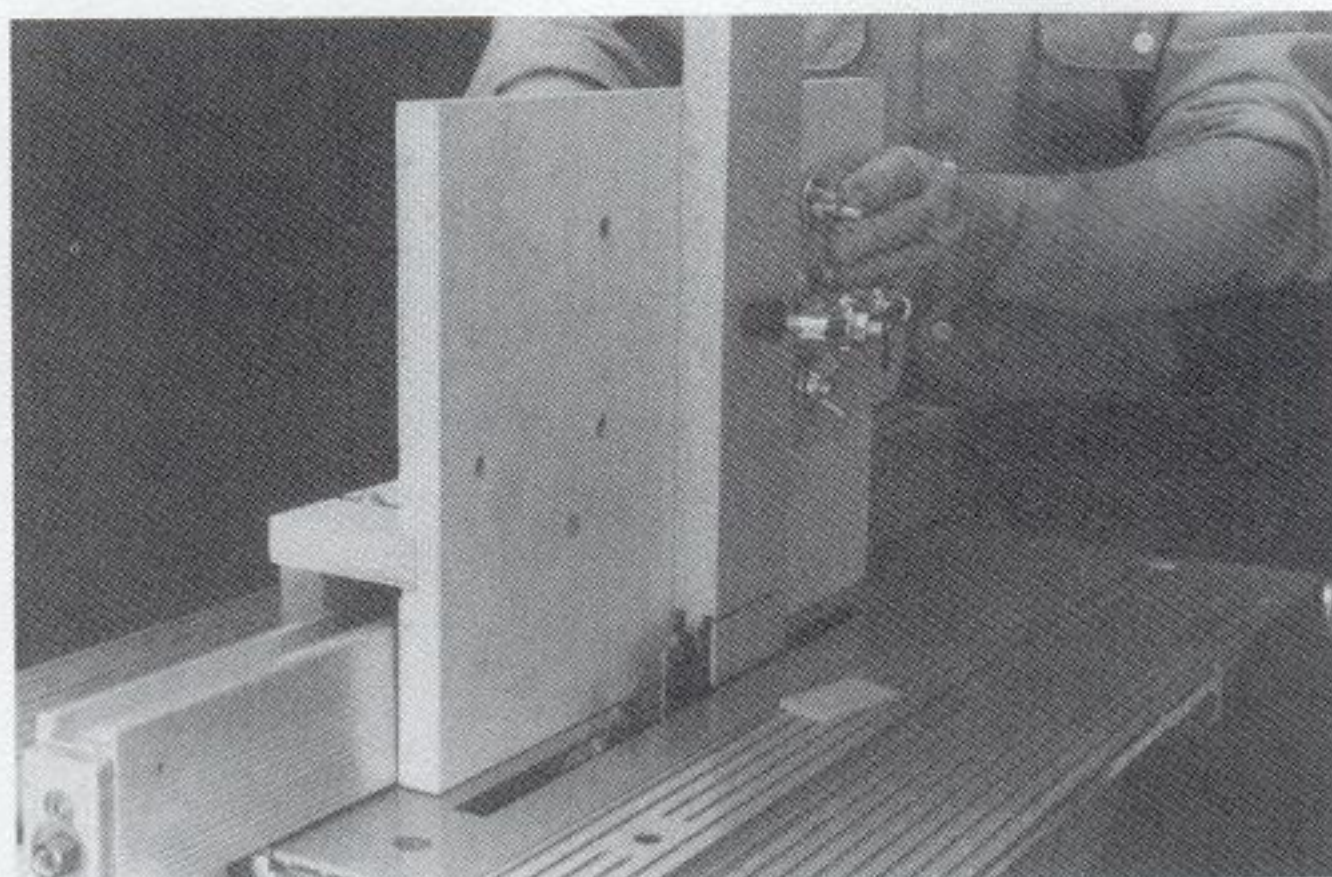

5-14 Next, cut the cheeks, using a tenoning jig to hold the stock as you slide the jig along the fence. Test fit the tenon in its mortise. If it's too *tight*, move the fence *closer* to the blade — this will shave a little more stock from the tenon. If it's too *loose*, move the fence *farther away* — this will make the tenon thicker.

miter gauge to guide the stock. (SEE FIGURES 5-15 AND 5-16.) The disadvantage is that it usually requires more setup time — you have to remove the blade from your table saw and mount the dado cutter.

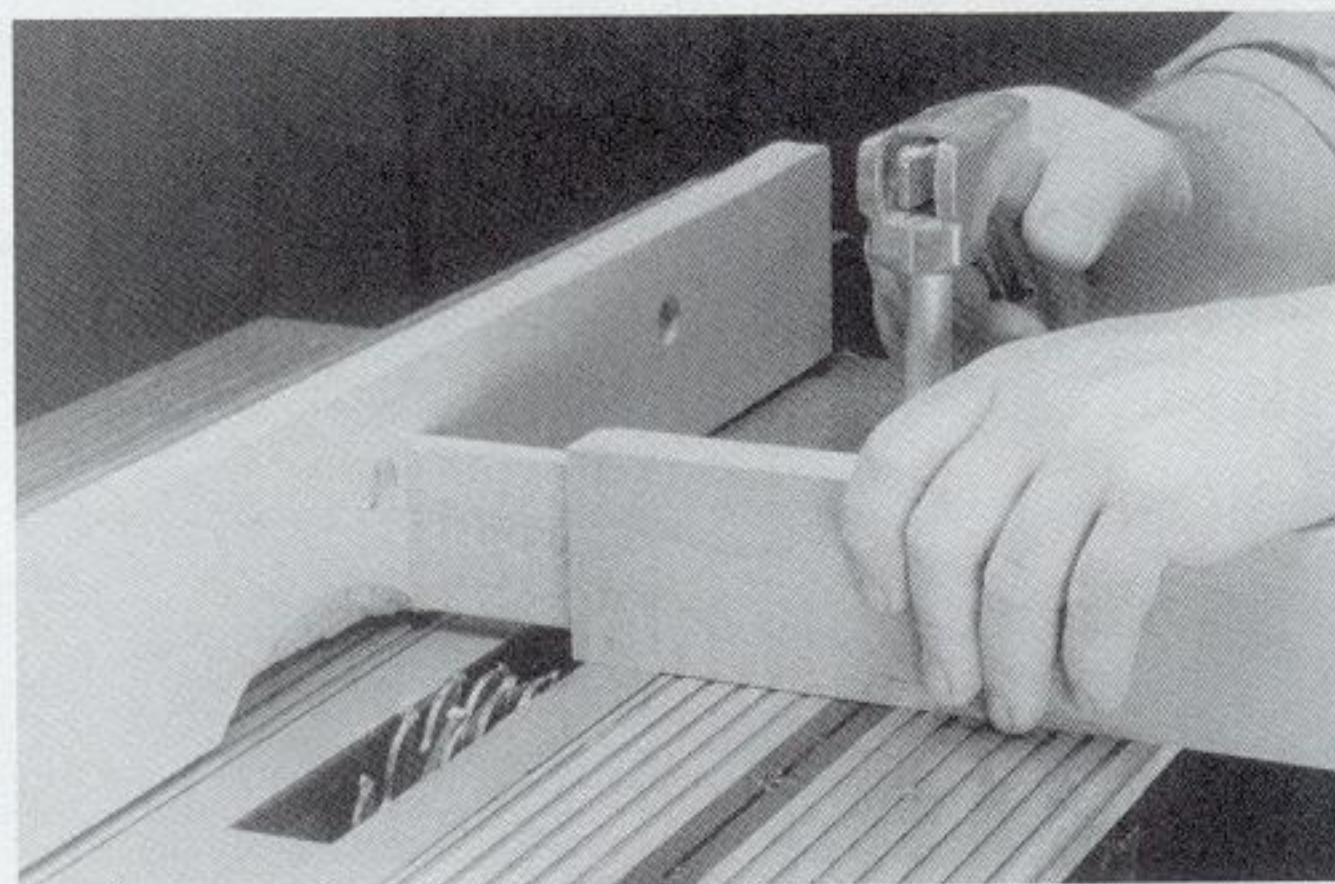

5-16 You can also use a miter gauge to guide the workpiece when cutting a tenon with a dado cutter. This setup allows you to make much longer tenons, since you aren't limited by the diameter of the cutter. It's also easier to cut shoulders and cheeks on all four sides of a tenon. The disadvantage is that you usually must make several passes to cut each tenon side.

Finally, you can cut a tenon on a table-mounted router, using a miter gauge to guide the workpiece over a straight bit. (SEE FIGURE 5-17.) Like a routed mortise, a routed tenon requires multiple passes over the bit — if you have lots of tenons to make, this isn't the tool to use. However, the routed cheeks and shoulders are extremely smooth. If the fit of the tenon or the strength of the glue bond is paramount, use a router.

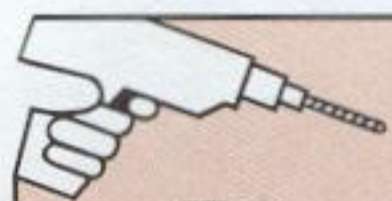

TRY THIS TRICK

To fit a mortise-and-tenon joint with no gap between the adjoining parts, it may help to undercut the shoulders of the tenon. Using a chisel, remove a small amount of stock from the shoulder where it meets the cheek.

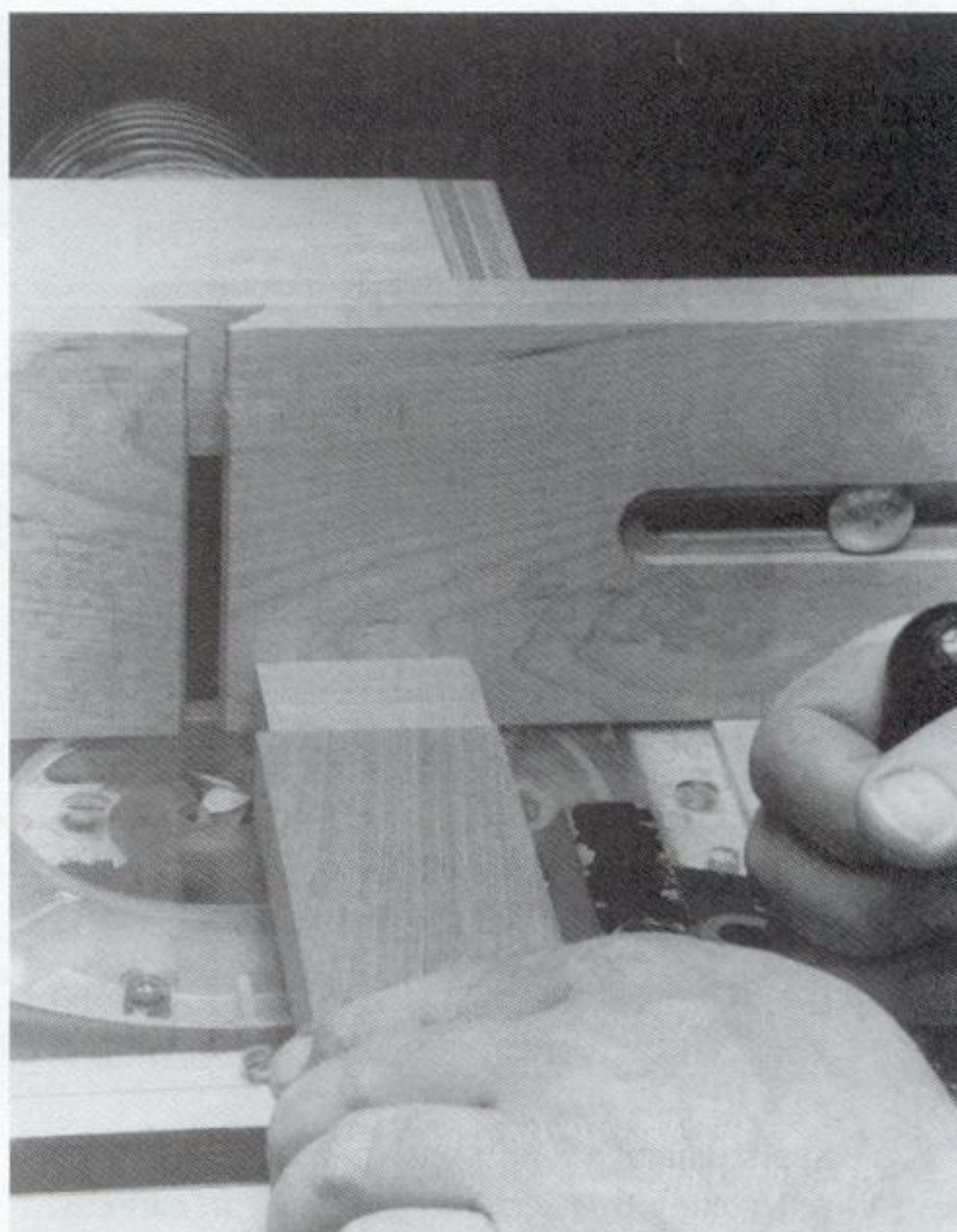
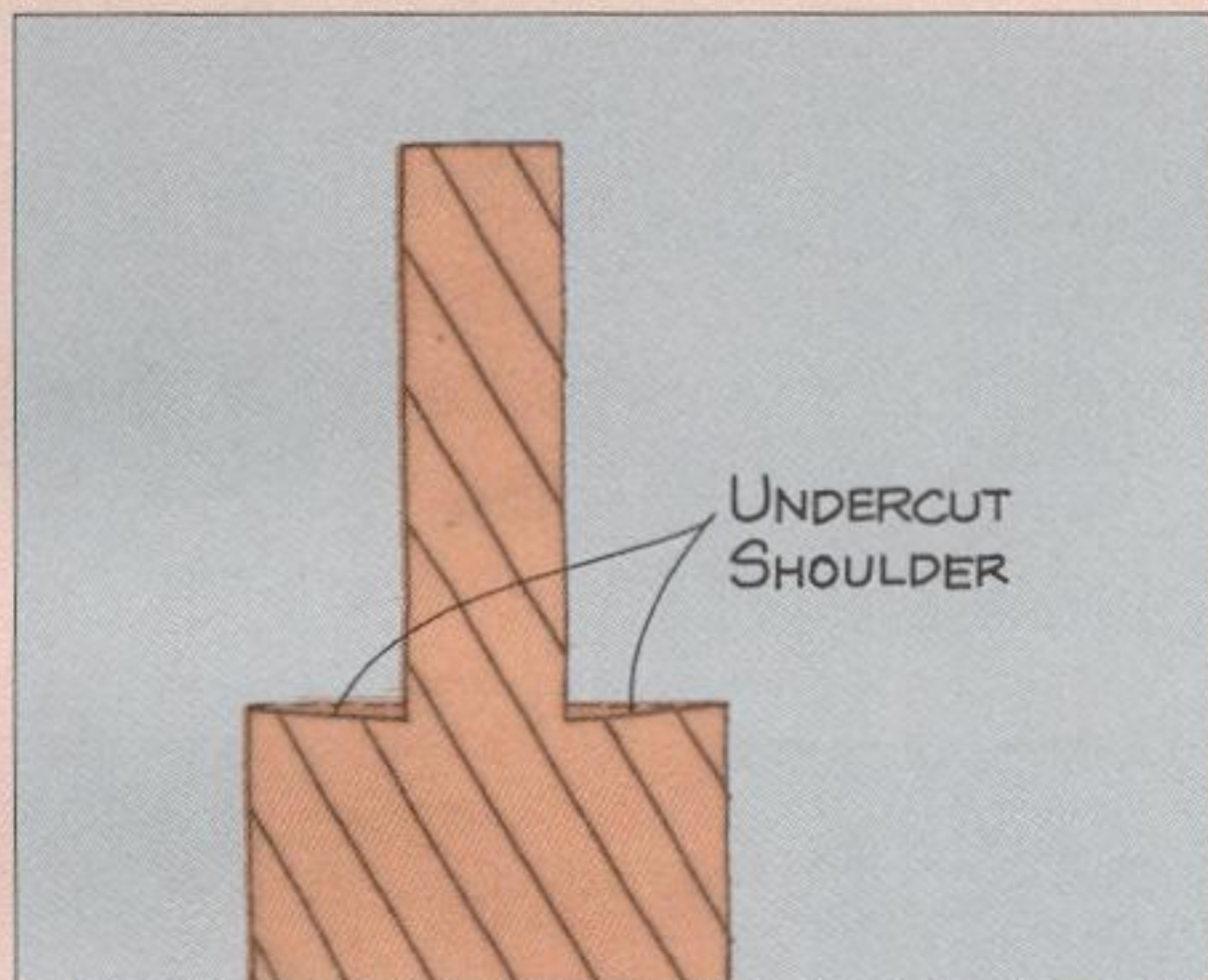

5-17 You can cut a tenon on a table-mounted router using a miter gauge to guide the tenon over the bit. Prevent the workpiece from creeping across the face of the gauge by positioning the fence just behind the bit. Make sure this fence is precisely parallel to the miter gauge slot, or the cut won't be accurate.

TENONING JIG

A tenoning jig holds a workpiece vertically to make a cut in its end. This particular jig rides along the table saw fence, like the "Splined Miter Jig" on page 56. The workpiece rests against a quadrant, and a clamp secures the workpiece to the vertical face of the jig. You can adjust the angle of the workpiece between 45 and 90 degrees by rotating the quadrant.

Make the vertical face and the spacer from $\frac{3}{4}$ -inch cabinet-grade plywood, and the remaining parts from hardwood. Cut or rout the slots in the

spacer and the quadrant. Also make the dado in the vertical face. Drill the holes needed to mount the quadrant and the clamp.

Glue and screw the spacer to the face. Secure the quadrant to the face with carriage bolts, washers, and wing nuts. (Note that there are six mounting holes, and the quadrant can be attached in four different positions.) Attach the leg to the spacer with roundhead wood screws and washers. Adjust the gap between the leg and the face to fit your table saw fence, then tighten the wing nuts.

PEGGING A MORTISE-AND-TENON JOINT

Craftsmen sometimes secure a tenon in a mortise by driving one or more pegs through the joint. The traditional method for pegging a mortise-and-tenon joint is to drive a *square* peg in a *round* hole.

This method works much better than using round pegs or dowels. The corners of the square pegs wedge themselves in the holes and can't work loose.

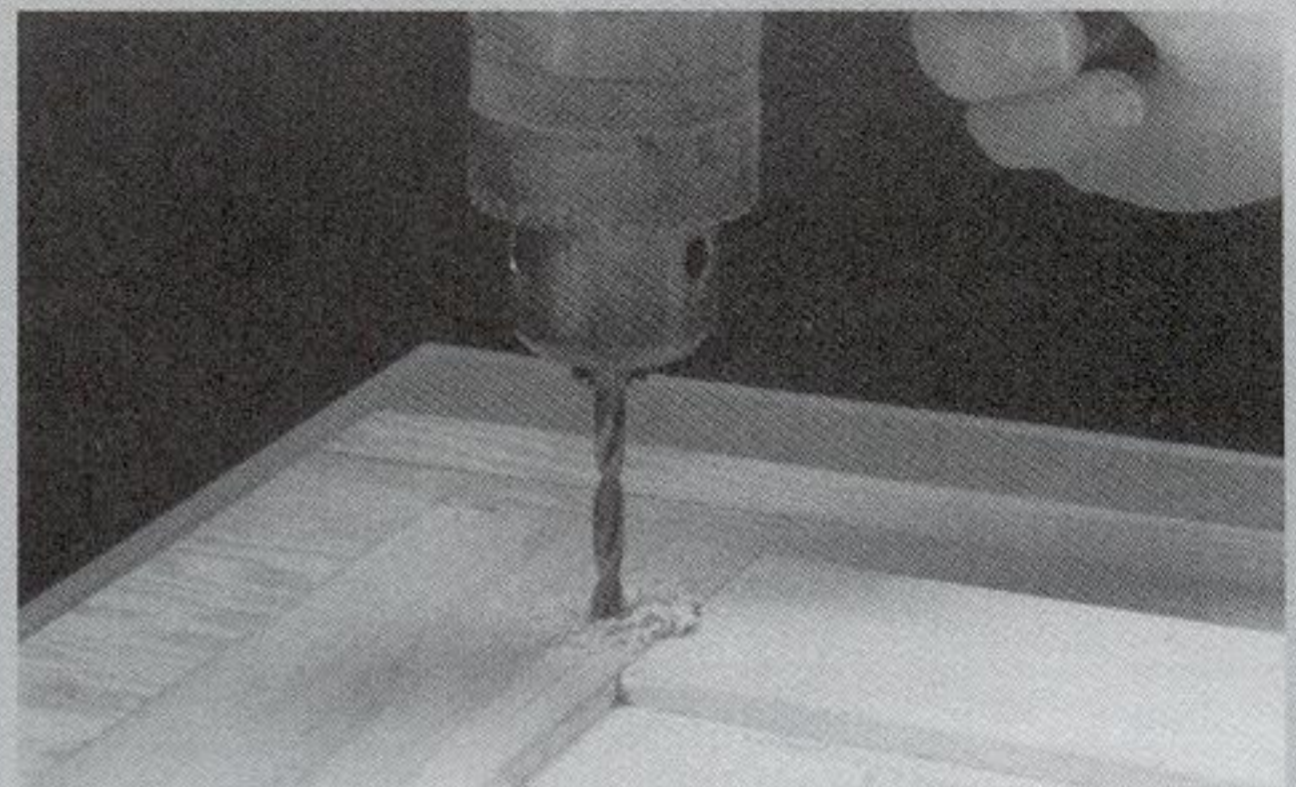
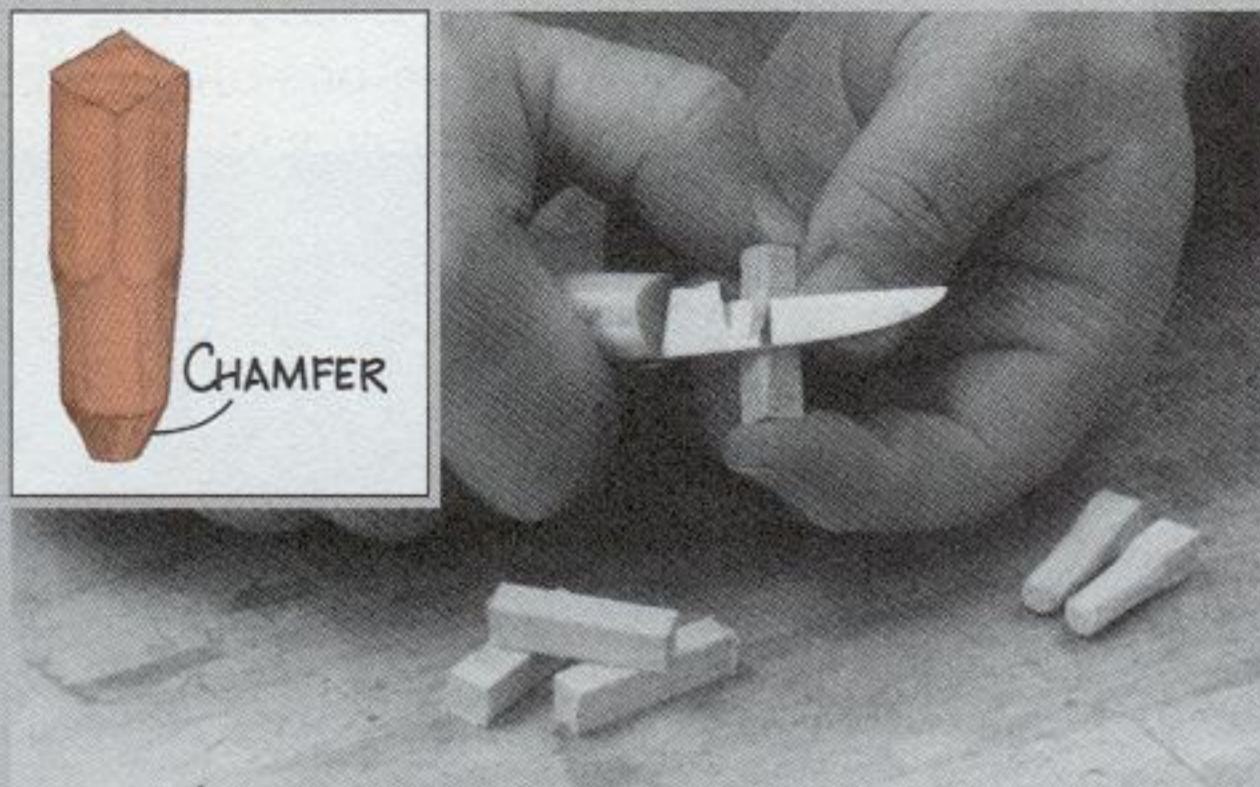

1 Make the pegs from a very hard wood, such as oak, maple, or hickory. Whittle about three-quarters of each peg's length, making it more and more round toward one end. When you're finished, one end should be round and the other end square. The square portion should be about $\frac{1}{2}$ inch long.

2 After assembling the joint, drill one or more holes, as big around as the peg is square, through both the mortise and tenon. **Note:** Don't locate the holes too close to the end of the tenon. The tenon might split when you install the pegs.

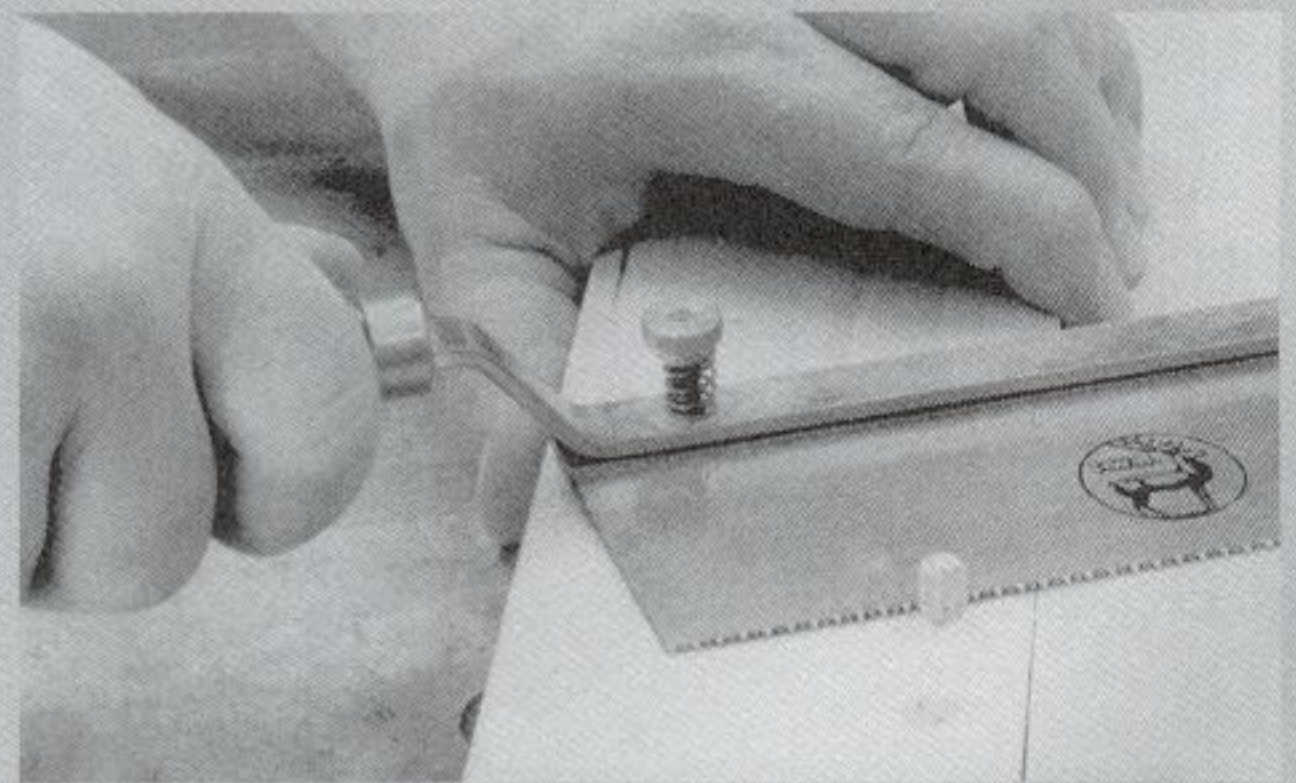
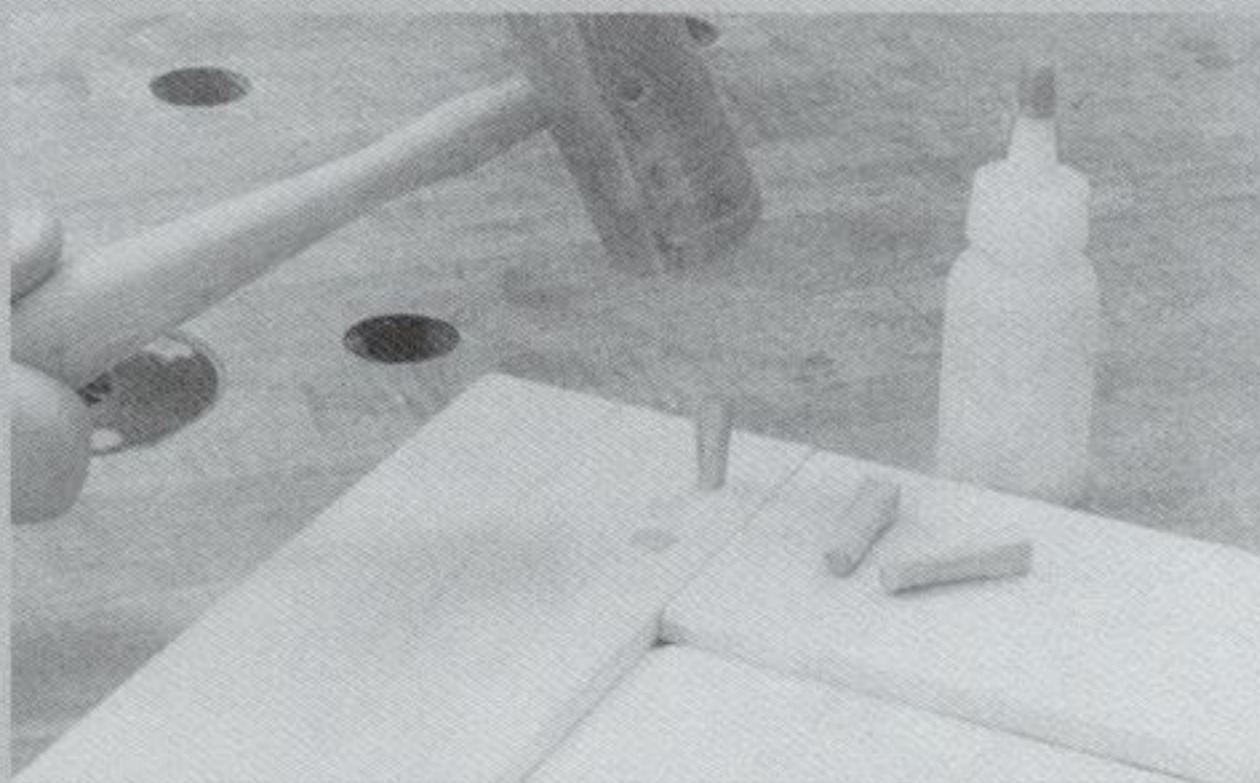

3 Coat each peg with glue and drive it into the hole, round end first. Tap it in until the square top is almost flush with the surface of the wood. Be careful not to hit the peg so hard that it splinters.

4 If the rounded portion of a peg protrudes from the back of the assembly, cut it flush with the surface of the wood. Lightly sand both the round end and the square end.

INTERLOCKING JOINTS

Just as most craftsmen consider mortises and tenons the best choice for connecting rails to stiles, legs to aprons, and for other *frame joinery*, they favor interlocking joints for assembling the sides of boxes, drawers, and chests — what is commonly referred to as *box joinery*. There is an important difference between these two types of joinery. Mortises and tenons join boards whose wood grain is oriented to shrink and swell in different directions. Interlocking joints, on the other hand, connect boards that move *in unison*.

This unity of movement allows you to cut intricate mating surfaces when making interlocking joints. Frame joinery is often very plain; if it were too elaborate, gaps would open up between the adjoining members as they expanded and contracted. This, in turn, would weaken the structure. But box joinery, such as dovetails and finger joints, can be as fancy as you want to make it. Consequently, many interlocking joints are both decorative and practical.

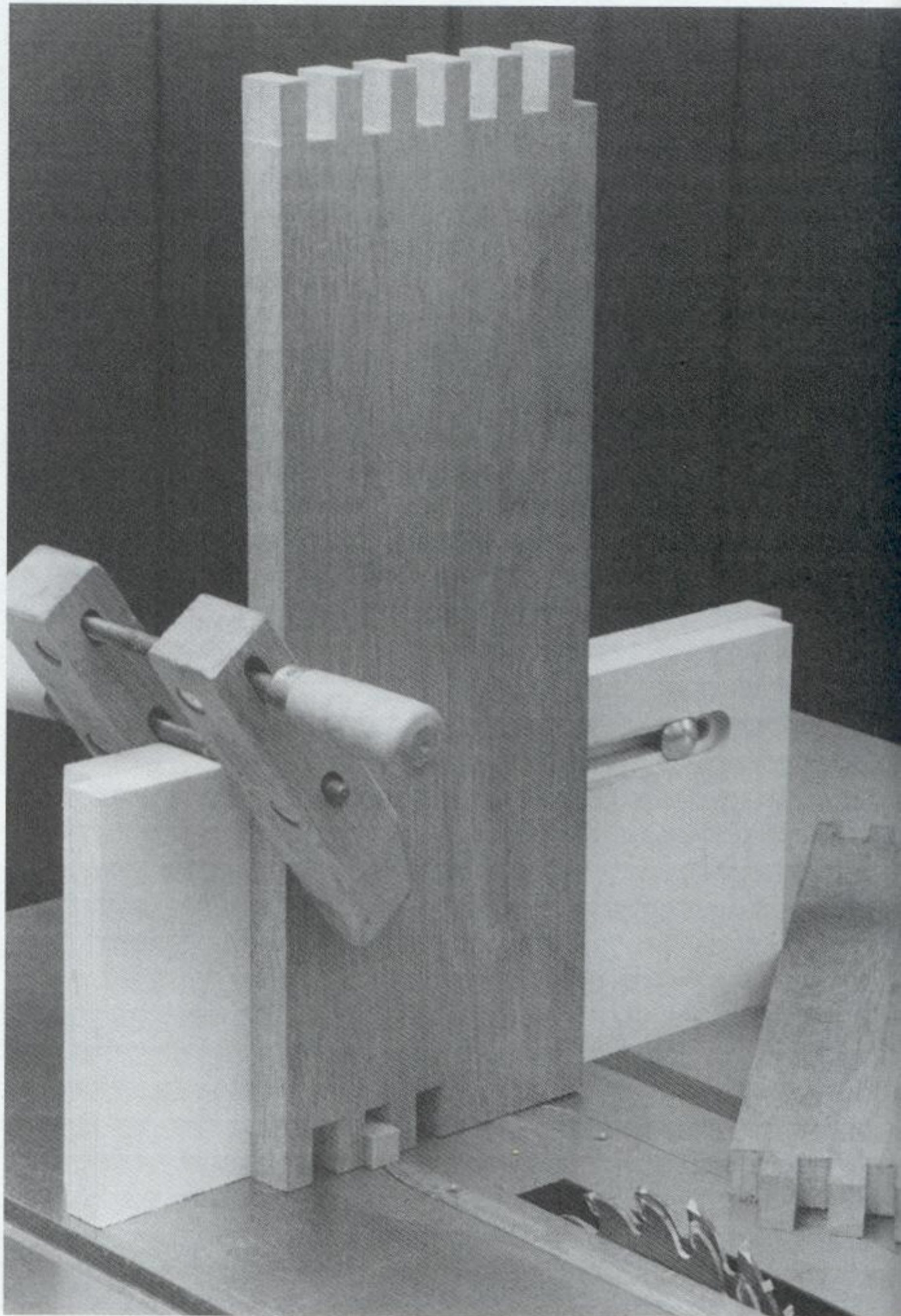

INCREASING GLUING SURFACE

Interlocking joints include various types of dovetail joints, finger joints, and lock joints, all of which require multiple cuts. (SEE FIGURE 6-1.) The common purpose of these joints is to increase the gluing surface in a corner joint. The mating surfaces of simple corner joints (butt joints, miter joints, and rabbet joints) are relatively small. Often, there are no long-grain-to-long-grain surfaces, just end-grain-to-long-grain and end-grain-to-end-grain. These circumstances combine to make a weak joint. The multiple cuts in an

interlocking joint multiply the surface area and often provide a healthy measure of long-grain-to-long-grain gluing surface.

Despite these multiple cuts, interlocking joints are not difficult to make. It's the *number* of cuts that cause an interlocking joint to look intricate, not the *complexity* of the cuts. Most joints require just one or two simple cuts that are repeated over and over again. As long as your layout and setup are accurate, the actual cutting will prove very easy.

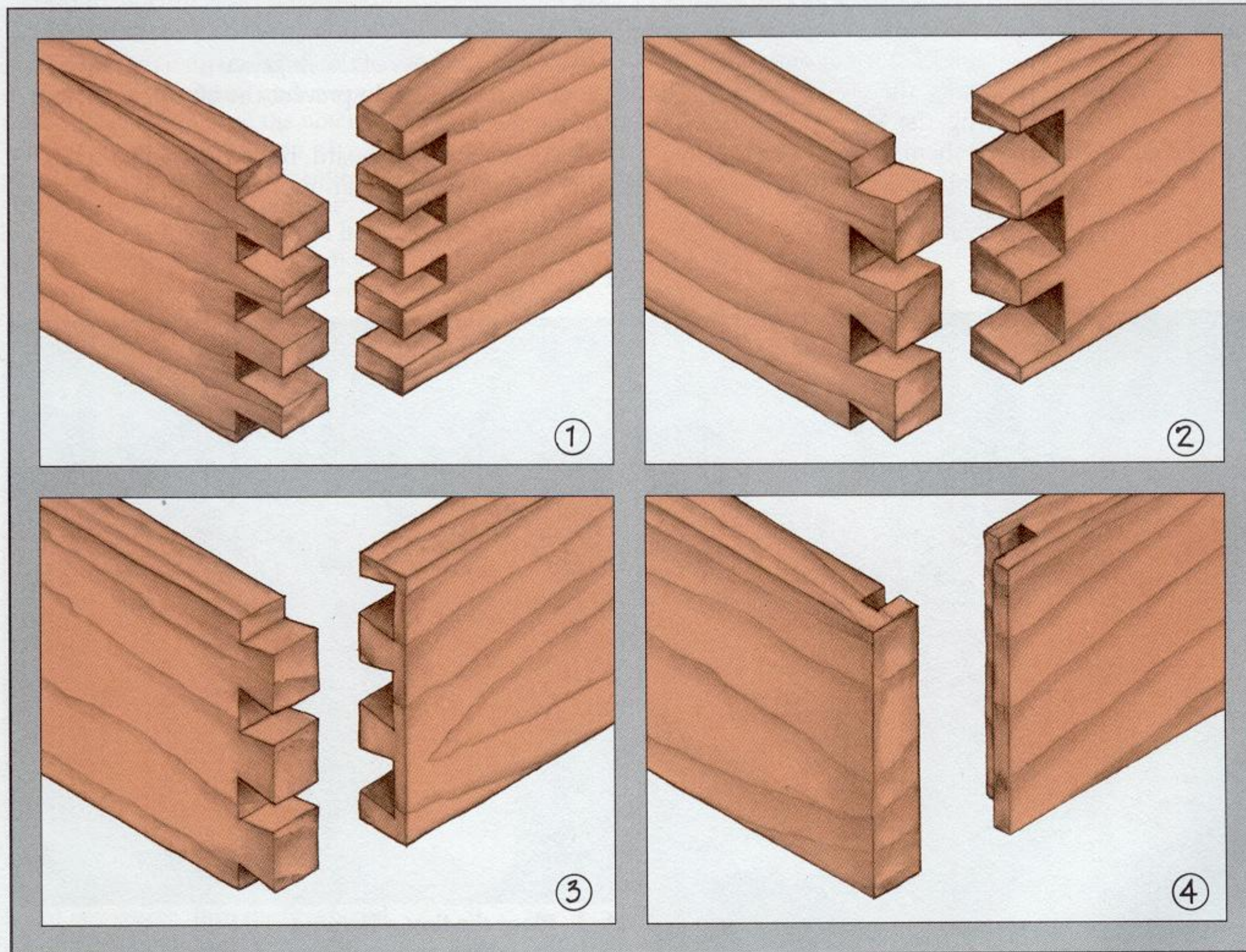

6-1 Of the many different types of interlocking joints, here are four of the most common: A *finger joint* (1), also referred to as a “box joint,” is used to join the corners of boxes. A *through dovetail joint* (2) joins boxes, chests, and the rear corners of drawers. A *half-blind dovetail* (3),

which can only be seen from one direction, is often used to join the front corners of drawers. A *lock joint* (4), also called a tongue-and-dado joint, is another joint that can only be seen from one side. It's often used to join the corners of drawers, especially small ones.

FINGER JOINTS

Finger joints are interlocking notches cut into the ends of adjoining boards. Usually, the notches are spaced evenly and they are all the same width. You can cut all the notches in both of the adjoining parts with a single setup, using a miter gauge and the “Finger-Joint Jig” shown on page 84.

The jig is designed to work on either a table saw with a dado cutter accessory, or a router table with a straight bit. You’ll find that it’s easier to make all sizes of finger joints on a table saw. It’s simple enough to make small finger joints in thin stock on a router table, but the procedure becomes progressively more time consuming as the fingers grow wider and the stock gets thicker. Remember, routers are designed to remove only small amounts of stock at one time.

When making finger joints, the setup is critical. The width of the stop on the jig, the width of the cutter, and the distance between them must all be *precisely* equal. Plan to make several test joints to fine-tune the setup before you cut good stock. (SEE FIGURES 6-2 THROUGH 6-6.)

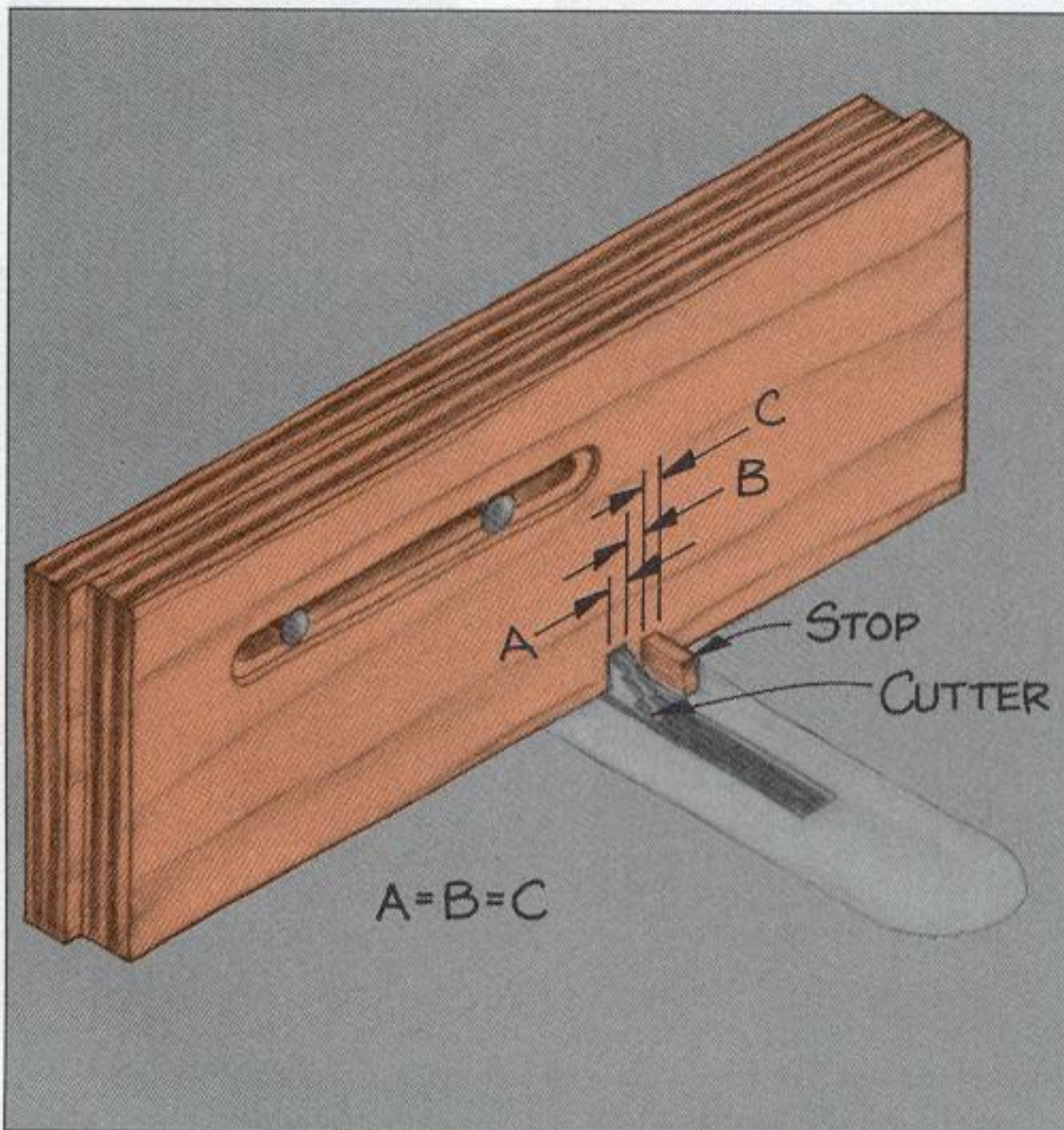

6-2 When setting up to cut finger joints, make sure the width of the stop and the width of the cutter are *precisely* the same. Slide the face of the “Finger-Joint Jig” on page 84 to one side or the other until the distance between the stop and the cutter is equal to the other two dimensions.

Here are several additional tips:

- The width of the adjoining boards should be a *multiple* of the finger width. For example, if the fingers are $\frac{1}{2}$ inch wide, the adjoining parts might be 5 inches, $5\frac{1}{2}$ inches, or 6 inches wide, but *not* $5\frac{1}{4}$ inches or $5\frac{7}{8}$ inches. If you can’t divide the finger width into the board width evenly, you’ll end up with partial fingers on one side of each board.

- The fingers should be *at least* as long as the width of the adjoining board. To be certain that they are long enough, cut them about $\frac{1}{32}$ inch longer than needed so they protrude slightly when the joint is assembled. Later, you can sand them flush with the wood surface.

- Scribe the base of the fingers with a marking gauge — this will help prevent the bit or cutter from tearing the wood grain.

- As you cut each board, back it up with a scrap. This too will prevent tear-out.

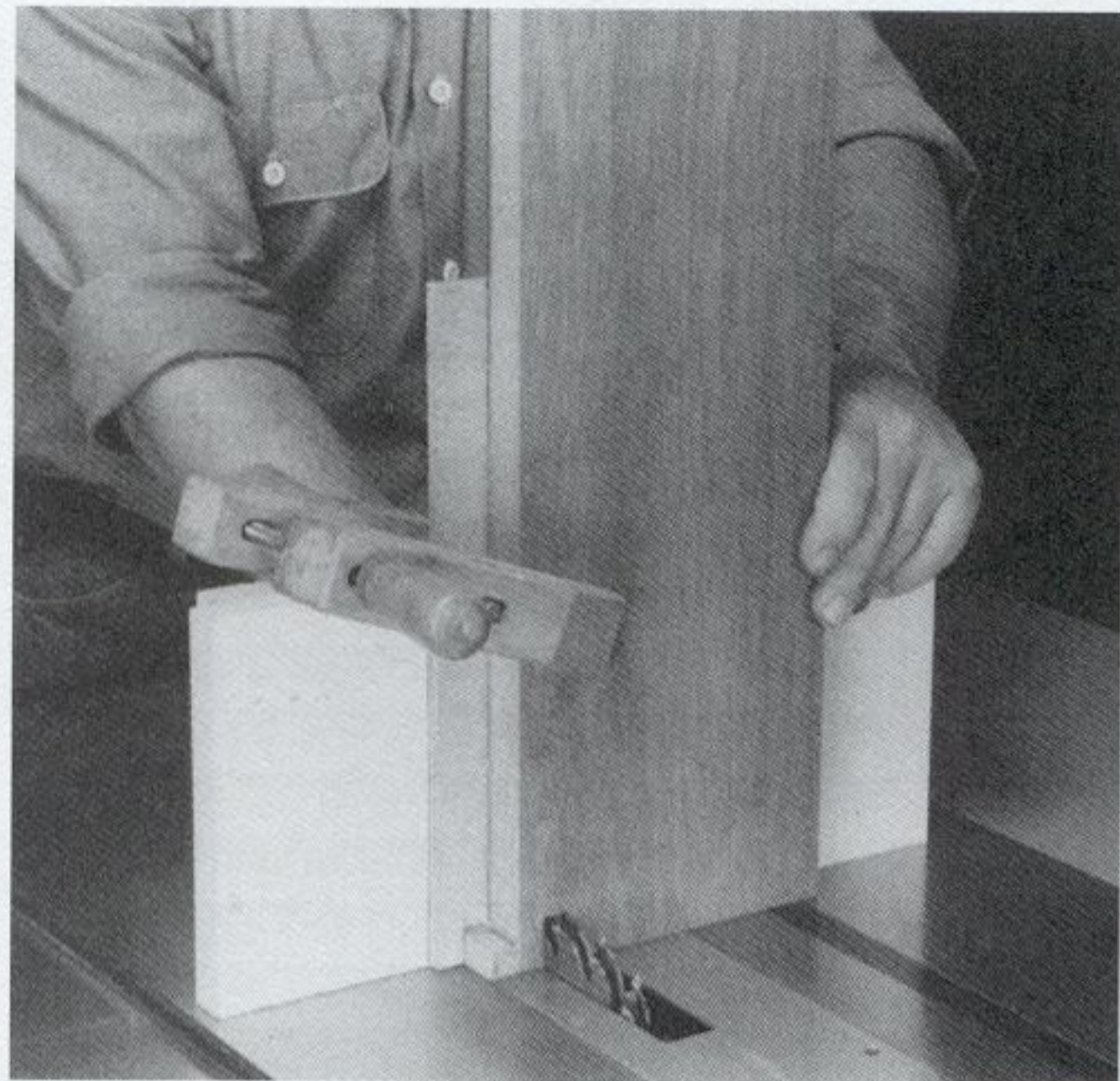

6-3 Place the first adjoining board end down against the face of the jig and slide it to one side until the edge butts against the stop. Clamp the board to the jig to prevent it from moving. Turn the saw on and slide the board forward, cutting the first notch. **Note:** To prevent tear-out, always back up the board with a scrap.

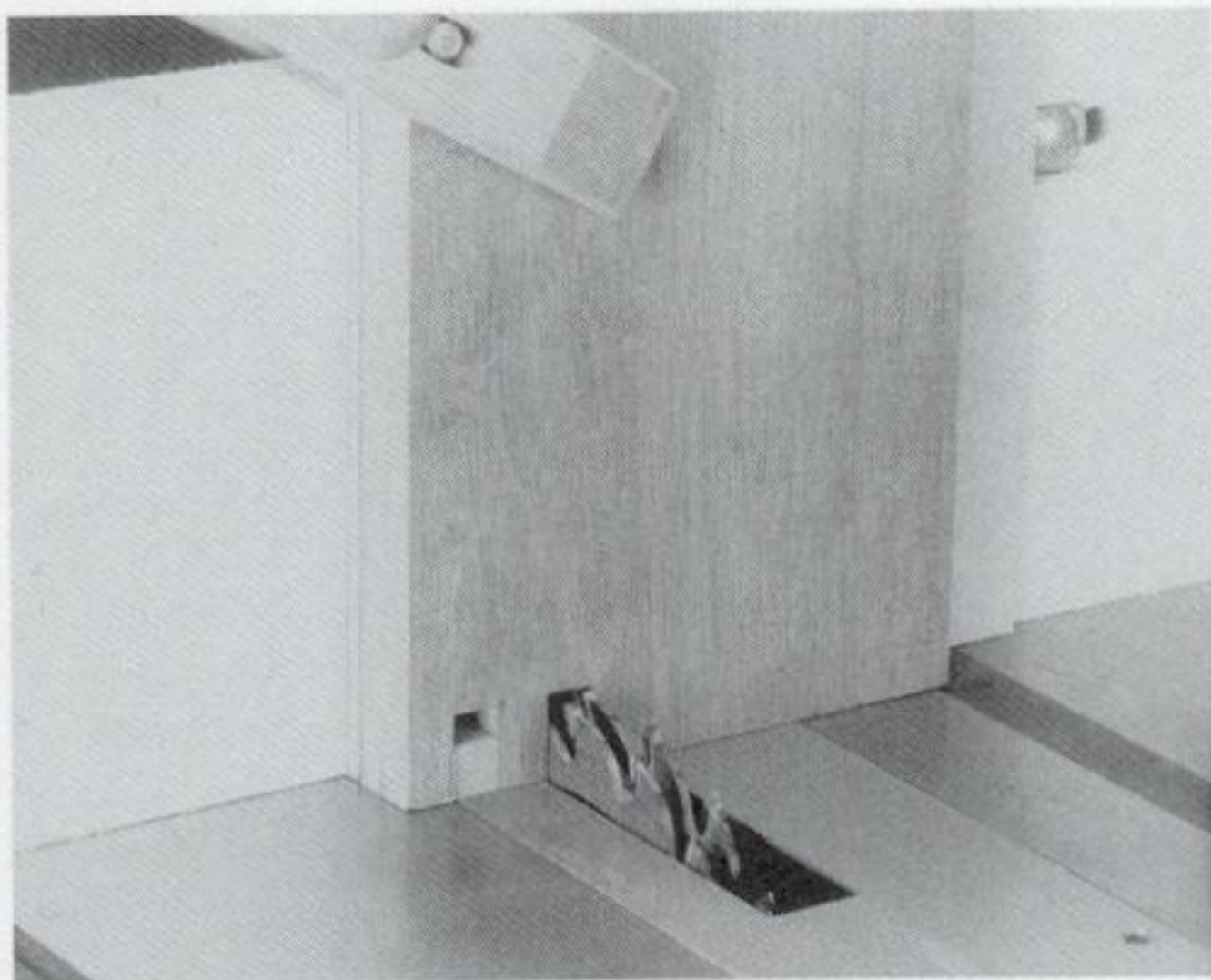

6-4 Loosen the clamp and move the board sideways until the notch you just cut fits over the stop. (It should fit snug, with no perceptible slop.) Tighten the clamp and cut another notch. Repeat until you have cut all the notches in the first adjoining board.

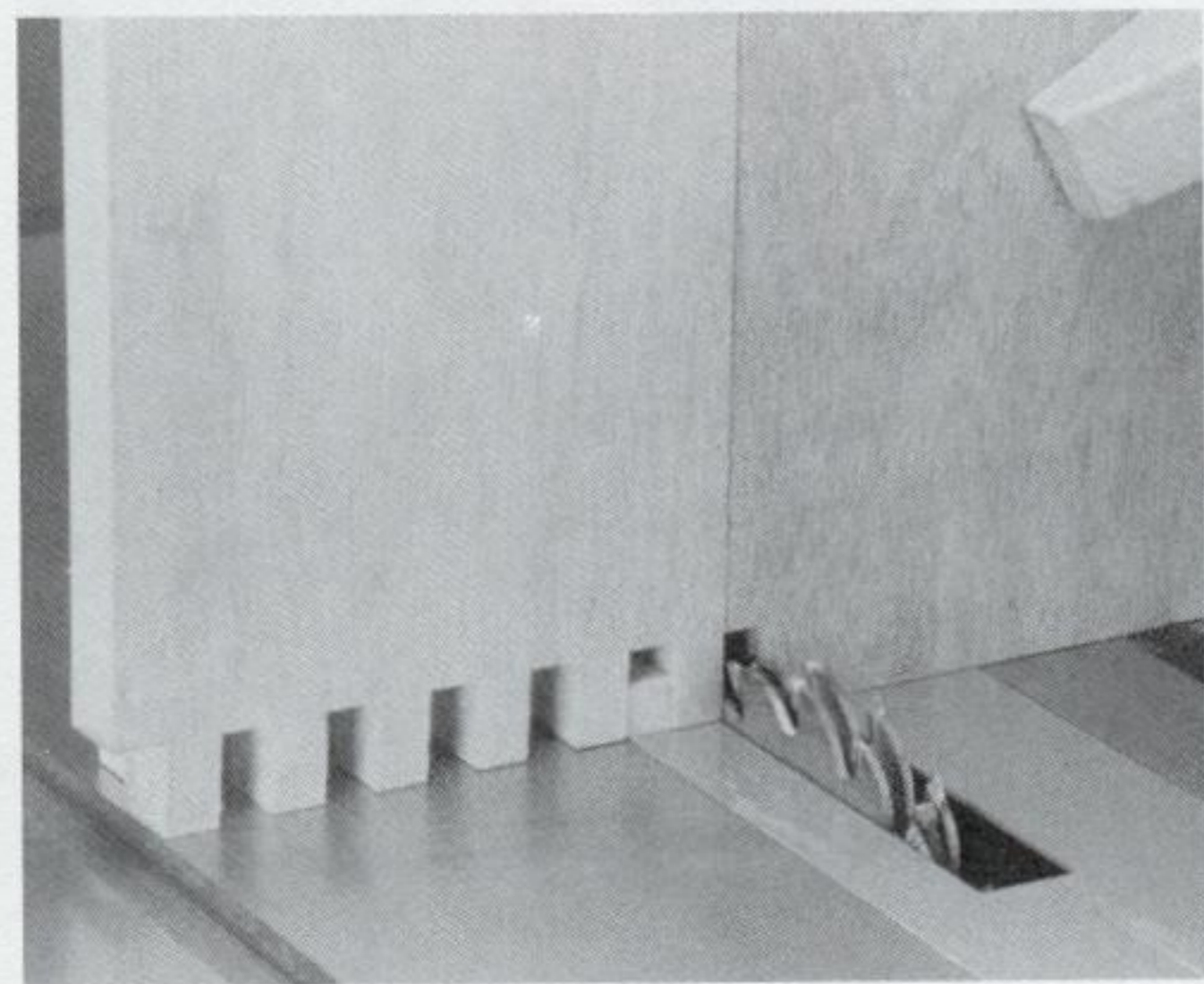

6-5 To cut the first notch in the second adjoining board, use the first board as a spacer. Turn the first board edge for edge and place the first notch over the stop. The first finger should fit between the stop and the cutter. Place the second adjoining board against the jig and slide it sideways until it butts against the first board. Clamp both boards to the jig and cut a notch. The first cut in the second board should create a *corner* notch.

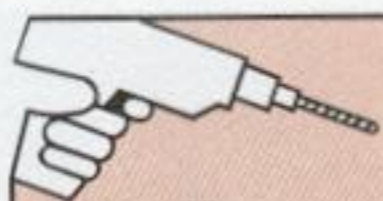

TRY THIS TRICK

To make a wooden hinge, round-over the ends of two boards with a router and a roundover bit. (The radius of this bit must be precisely *half* the thickness of the boards.) Cut finger joints in the rounded ends and assemble the joint. At the center of the rounded ends, drill a hole through the interlocking fingers. Insert a wooden or metal rod in this hole to serve as a pivot.

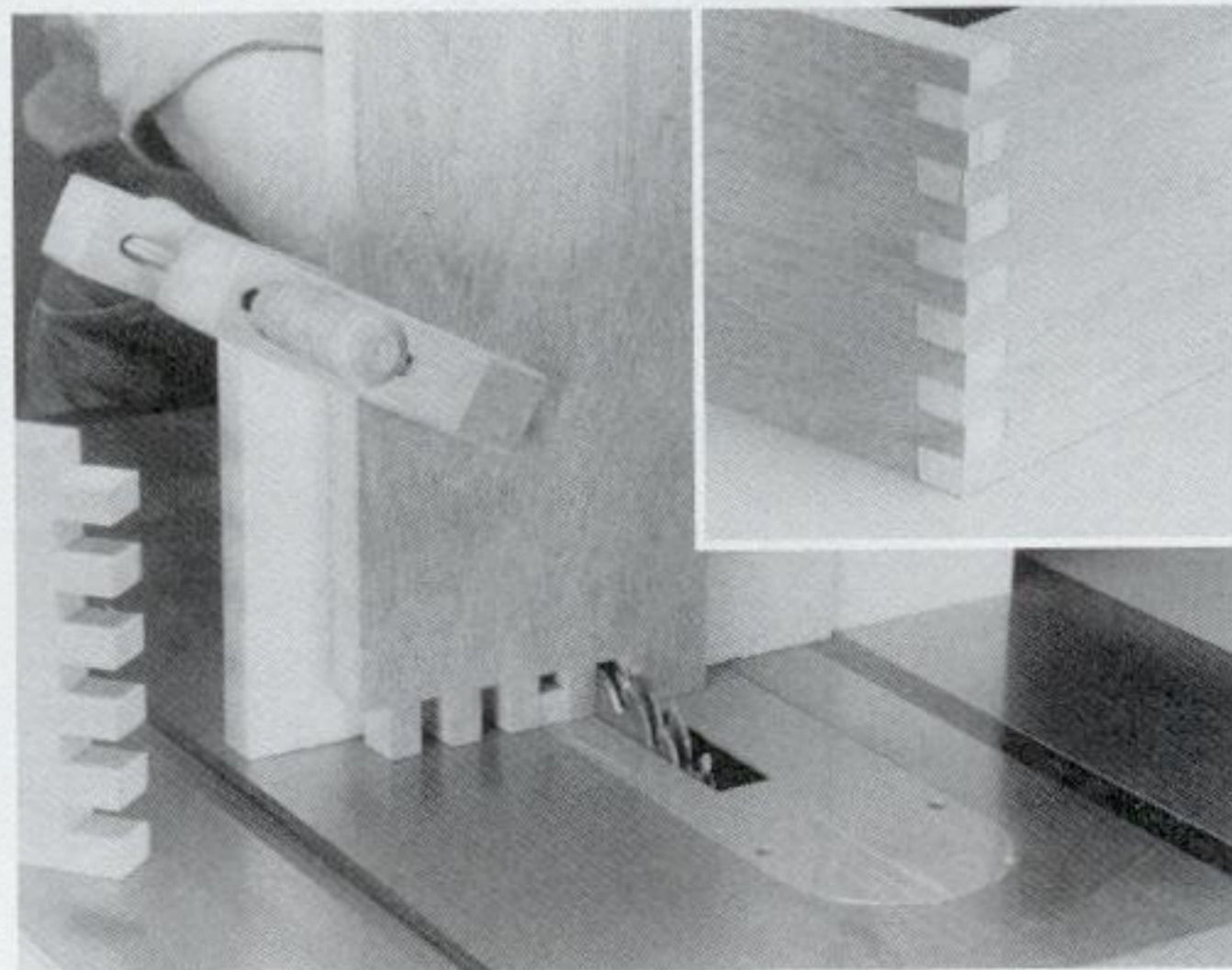
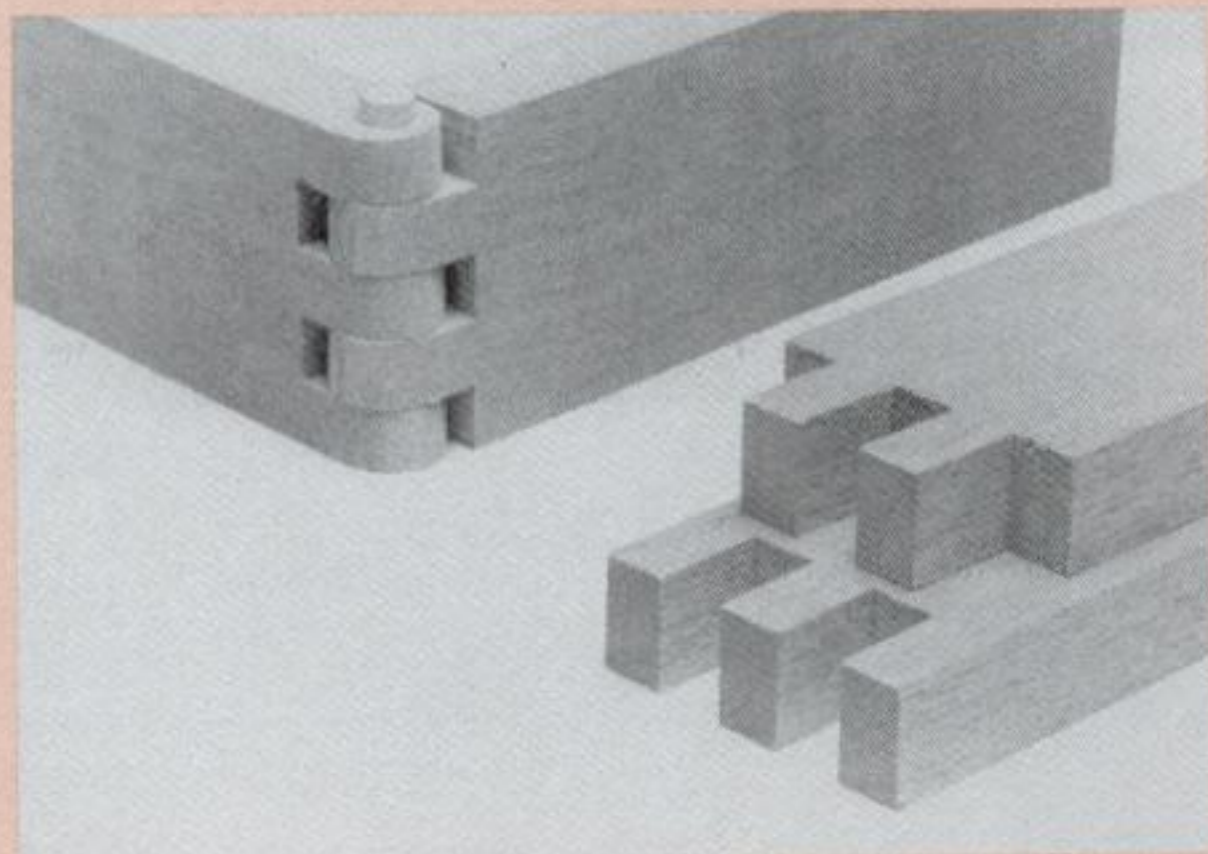

6-6 Continue cutting notches in the second board in the same manner that you cut them in the first. When you fit the boards together, the fingers and notches should interlock, and the edges of both boards should be flush. If the joint is too *tight*, move the stop *toward* the dado cutter slightly. If it's too *loose*, move it *away*.

FINGER-JOINT JIG

This jig will evenly space notches as you cut them, allowing you to make finger joints. It's designed to mount on any miter gauge, and will work on both a table saw and a router table. Make the face and the mount from cabinet-grade plywood, and the stop from hardwood. If you wish, make several different faces, each with a different size stop. This will enable you to cut different sizes of finger joints.

To use the jig, screw or bolt the mount to a miter gauge. Loosen the wing nuts that secure the face to the mount and slide the face sideways until the stop is the proper distance away from the bit or cutter. When the stop is positioned properly, tighten the wing nuts.

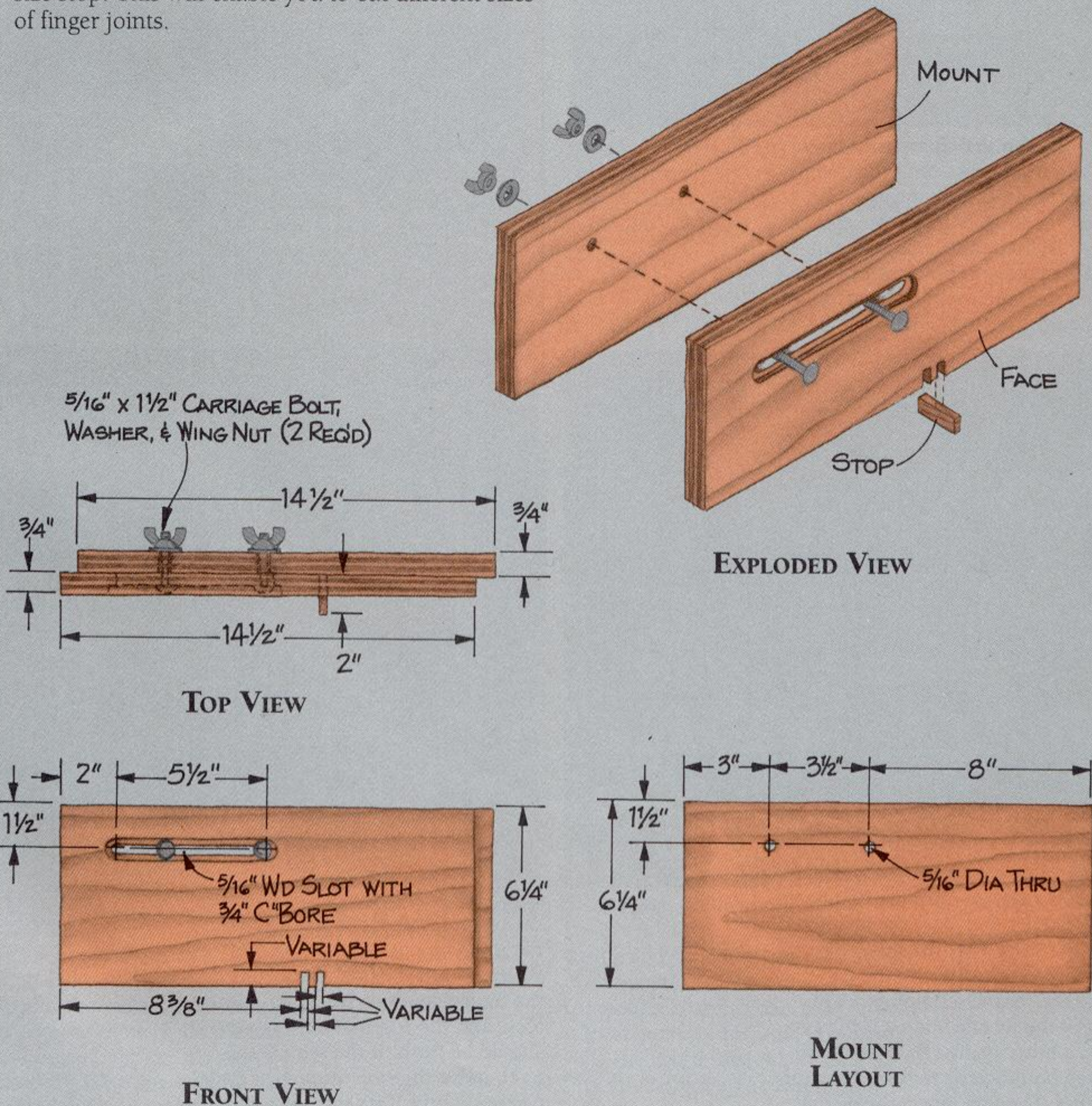

THROUGH-DOVETAIL JOINTS

Through-dovetail joints have fascinated and frustrated woodworkers for ages. Although there are several different ways to cut them with power tools, no one has yet developed a machine or a fixture to make “classic” dovetail joints — the wide, graceful tails and narrow, delicate pins that have become the hallmark of fine, hand-built furniture. (SEE FIGURE 6-7.) Careful, patient handwork with a chisel and a dovetail saw remains the only way to make this joint. (SEE FIGURES 6-8 THROUGH 6-18.)

However, there are several simple jigs that will help you through this handwork — the *Layout Rule*, *Slope Gauge*, and *Chisel Guide*. You’ll find the plans for all three of these jigs in “Dovetail Aids” on page 90.

Before making a dovetail joint, decide which part to cut first — the pins or the tails. Craftsmen will argue the point at great length. I prefer to make the tails first, then use these as a template to mark the pins. (I find it more difficult to use the pins to mark the tails.) Here are several additional tips:

- Make sure that your chisels are razor sharp. Some craftsmen keep a set of finely honed chisels that they use *only* for making dovetail joints.

- Choose clear, straight-grained wood for the members. It’s very difficult to hand cut dovetail joints in figured wood. Also, the grain must run lengthwise through the pins and tails.

- When you lay out the pins and tails, clearly mark the waste so you don’t accidentally remove the wrong part of the board.

- Keep the slope of the pins and tails between 8 and 12 degrees. If the slope is less than 8 degrees, the pins won’t remain wedged between the tails as firmly as they should when the joint is subjected to racking stress. If it’s more than 12 degrees, the cheeks of the tails become fragile and will shear off. This makes the joint more susceptible to shear stress.

- Always cut on the *waste* side of the layout lines. This will ensure that the joints fit tightly. It’s much easier to shave a little stock from the pins of a dovetail joint that fits too tight than it is to shim the pins of a loose joint.

- Make both the pins and the tails about $\frac{1}{32}$ inch longer than the thickness of the adjoining boards. After assembling the joint, sand the outside surfaces flush.

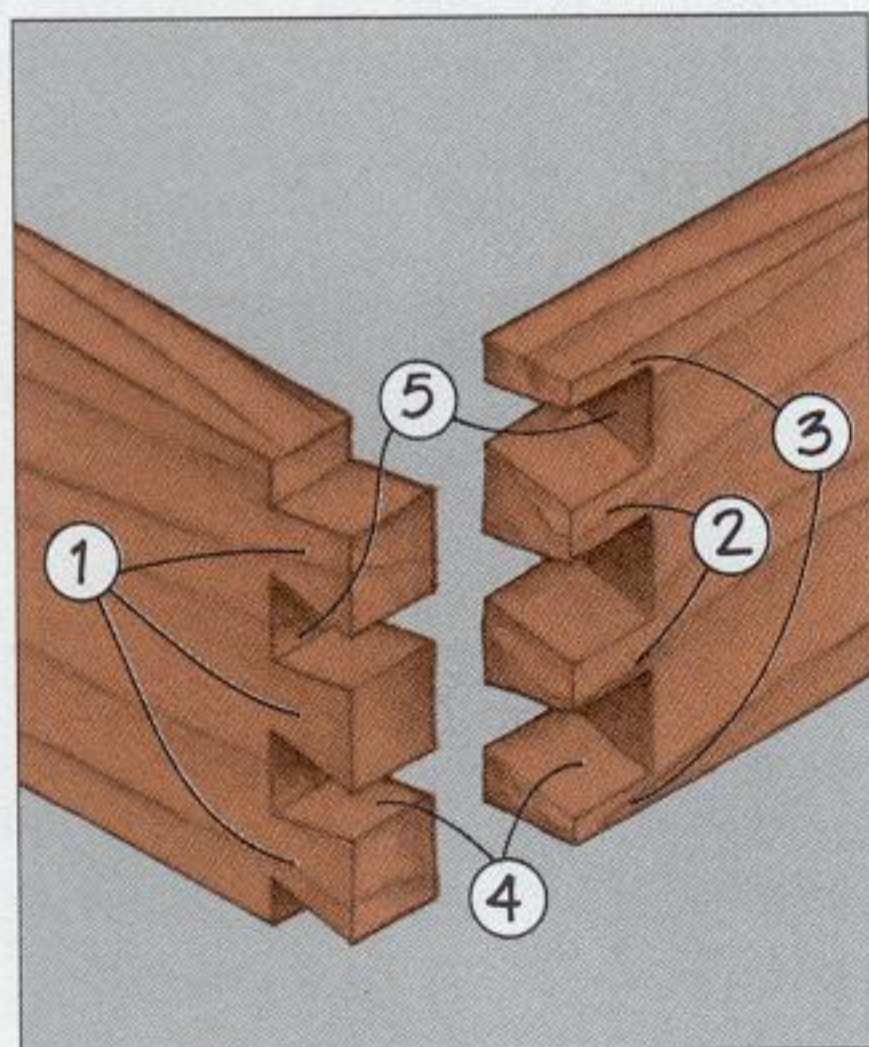

6-7 All dovetail joints consist of two parts. The *tails* (1) are cut into one of the adjoining members, and the mating *pins* (2) are cut into the other. Traditionally, dovetail joints have split pins or *half pins* (3) at the top and bottom edge — tails are not usually split. Each of the tails, pins, and half pins are tiny tenons with angled *cheeks* (4) and square *shoulders* (5).

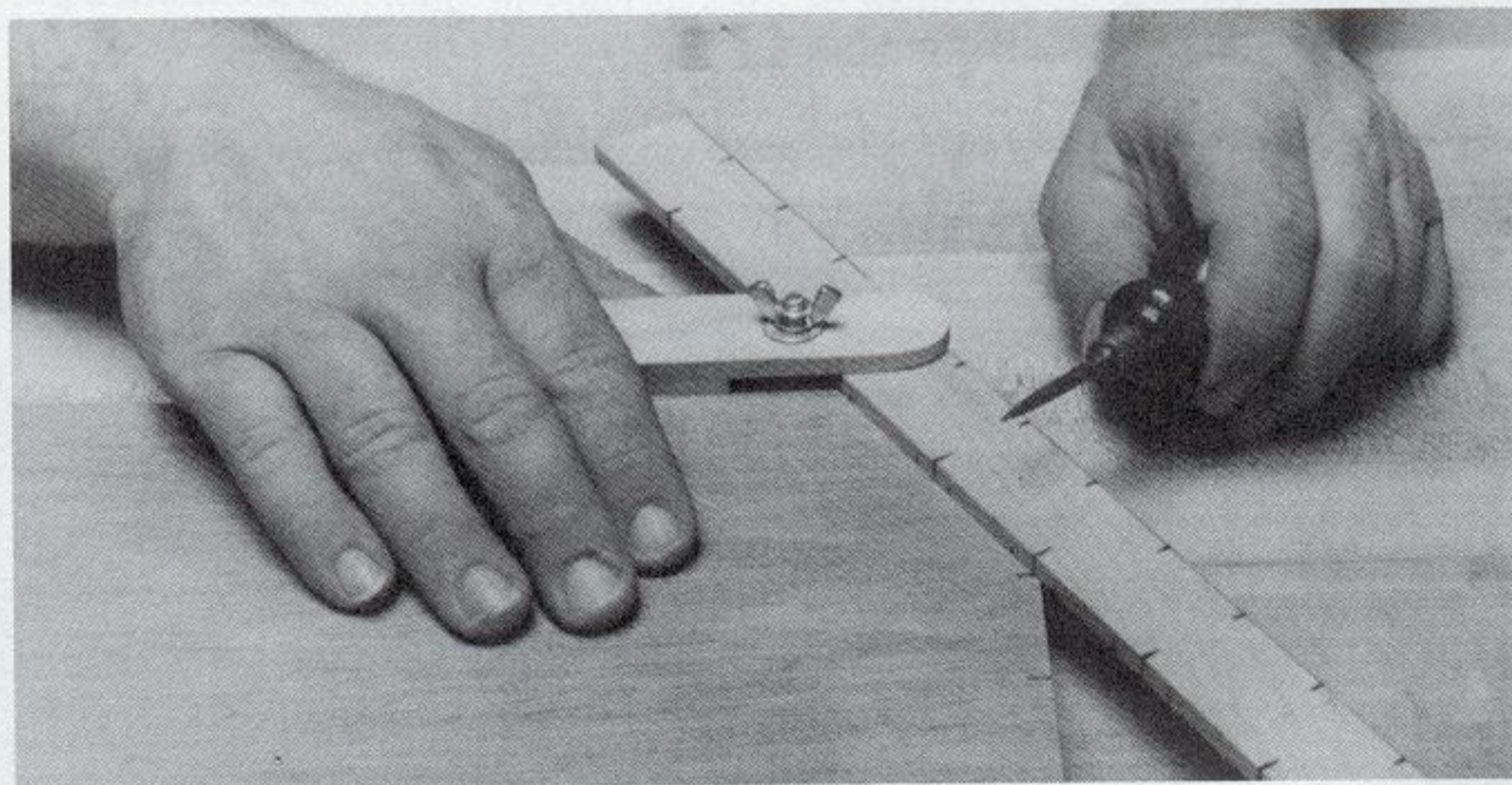

6-8 To make a through-dovetail joint — or *any* dovetail joint — first mark the spacing of the dovetails. Decide how many tails you want to cut across the width of the tail board. For example, if you want to cut five dovetails (five tails and six pins) across the board, hold the *Layout Rule* (see page 90) at an angle, using five spaces — no more, no less — to span the width. (For small dovetails, use the edge on which the lines are 1 inch apart;

for larger dovetails, use the side on which the lines are $1\frac{1}{2}$ inches apart.) Place the holder against one edge of the board and slip it onto the rule, gripping the rule at the proper angle. Keeping the holder against the board’s edge, slide the rule toward the end of the board. Where each line on the rule crosses the end, make a mark on the board. When you’re finished, there should be four marks on the end of the board, dividing its width into five equal sections.

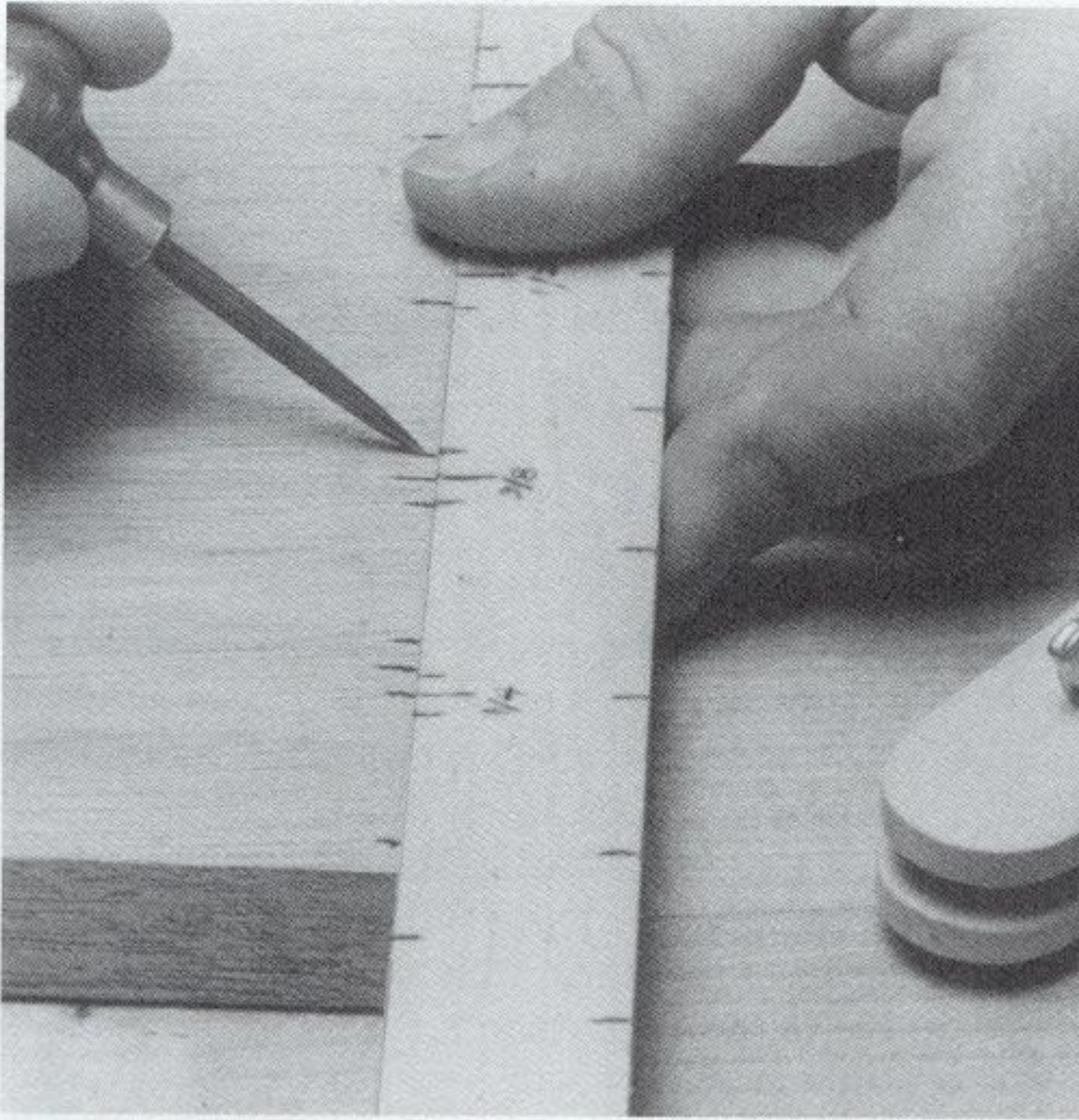

6-9 Next, decide how wide to make the pins. The narrowest part of the pin — the side that will be flush with the outside of the assembled joint — must be *at least* as wide as your smallest paring chisel. Using the special marks on the *Layout Rule* that indicate pin width, mark the narrow sides of the pins at each of the spacing marks, as shown. Remember to mark *half* pins at the top and bottom edges of the board. Using a small square, transfer these marks to *both* sides of the board.

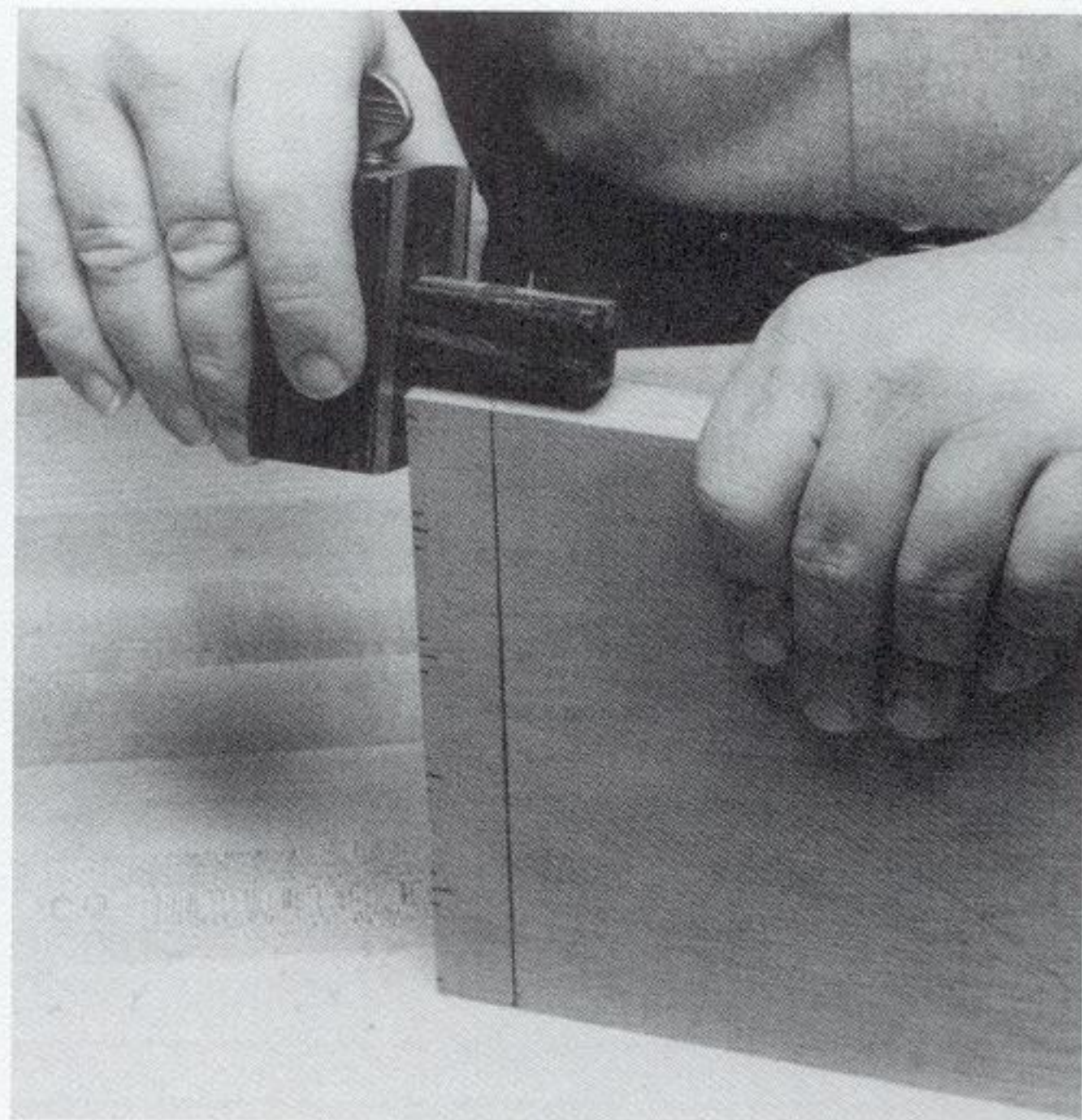

6-10 Using a marking gauge, scribe the base of the tails on both sides and both edges of the board. Be sure to set the marking gauge for $\frac{1}{32}$ inch more than the wood thickness, as mentioned previously.

6-11 Mark the angled cheeks of the tails with the *Slope Gauge* (see page 90), scribing angled lines from the baseline to the marks that indicate the width of the pins. Mark all the right-sloping cheeks, then turn the gauge over and mark the left-sloping cheeks. Remember to mark *both* sides of the board. Shade the stock between the tails to indicate the waste.

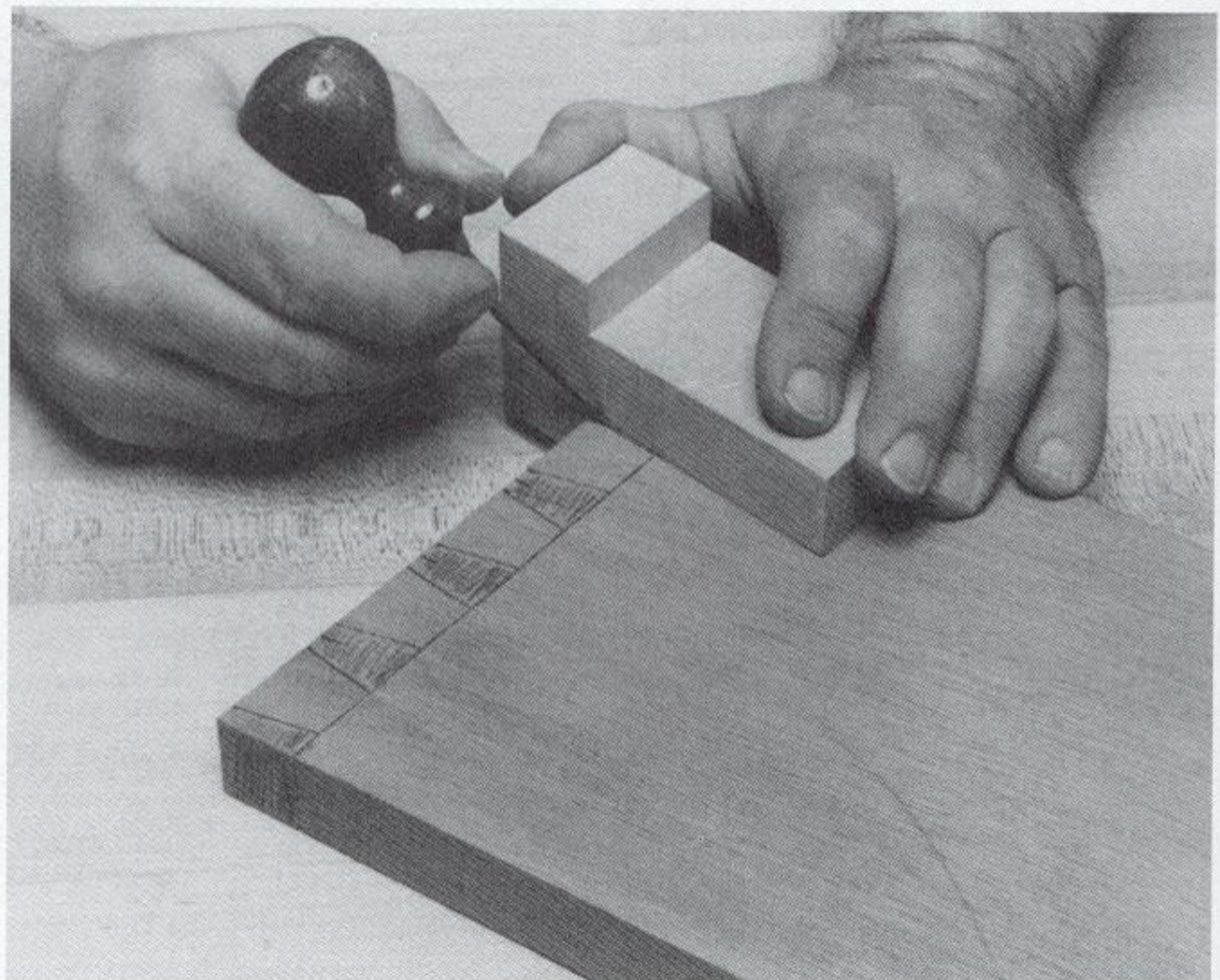

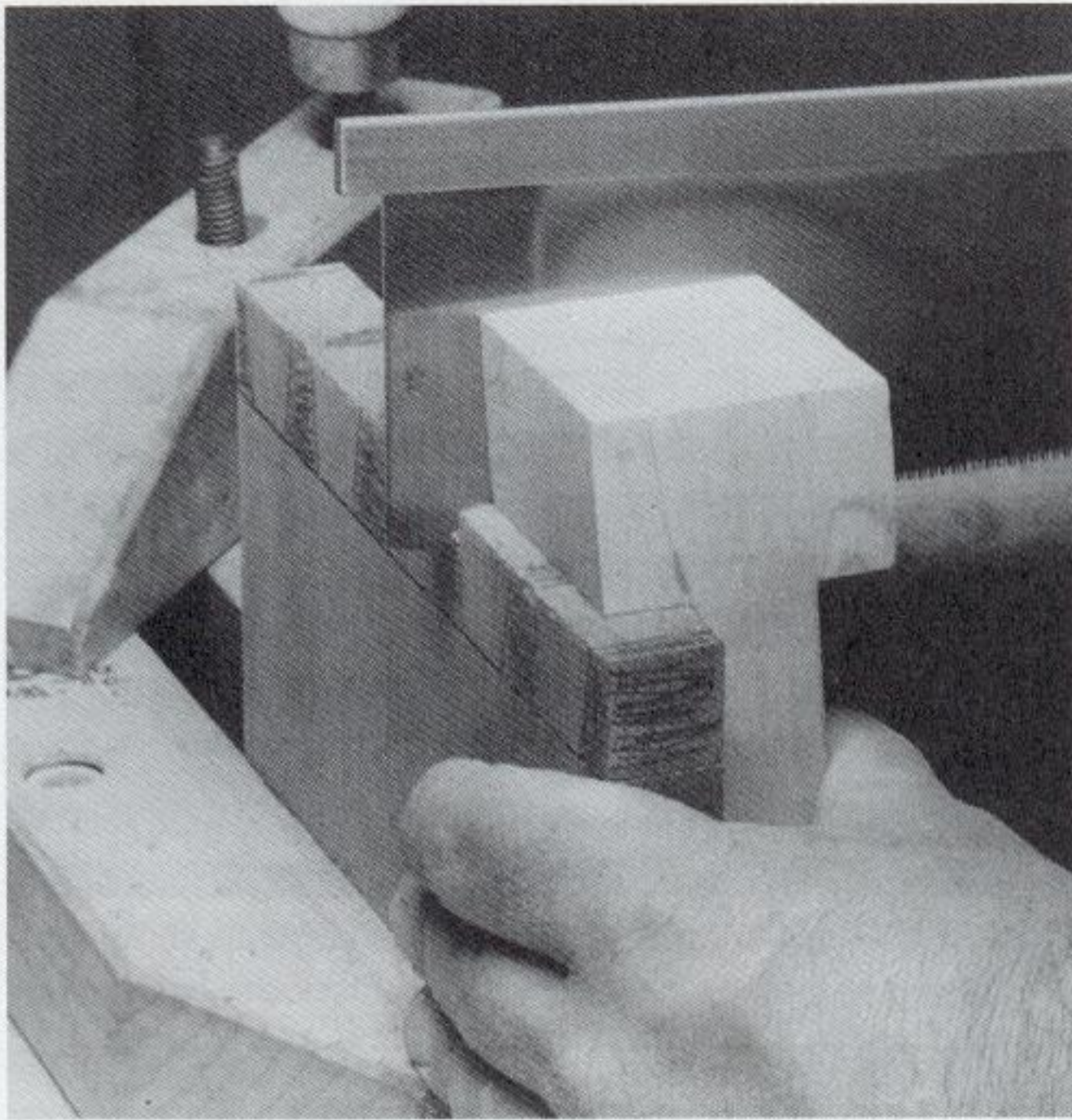

6-12 Using a dovetail saw or a dozuki saw, cut the sloping cheeks down to the baseline. If you wish, use the *Slope Gauge* as shown to help start the cut. You can also use the *Chisel Guide* (see page 90) to hold the board as you cut it.

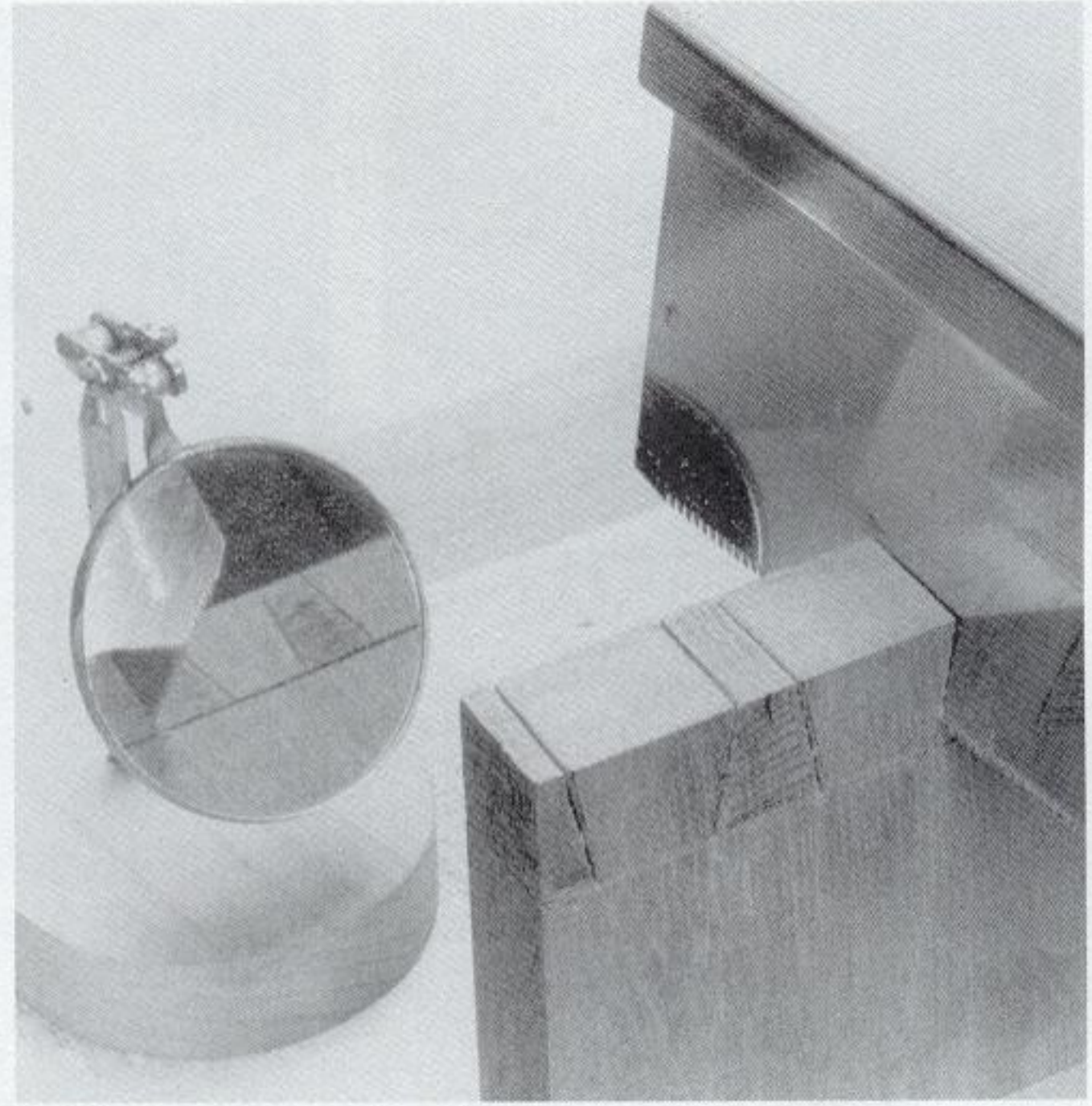

6-13 As you cut the cheeks, you must monitor *both* sides of the board, making sure the saw follows both sets of layout lines. You can do this with a great deal of head bobbing, or you can use the *Third Eye* (see page 31) to keep watch on the side of the board facing away from you.

6-14 Once you've cut the cheeks of the tails, cut along the baseline to remove the waste. Do this with a chisel, using it alternately as a cutting tool and a wedge. Clamp the board in the *Chisel Guide*, aligning the guide block with the base layout line. Place the chisel so the edge is on the layout line and the back is flat against the guide block — this will hold the chisel vertically at precisely 90 degrees to the surface of the stock. Strike the chisel lightly with a mallet, cutting through the grain and about $\frac{1}{16}$ inch into the wood.

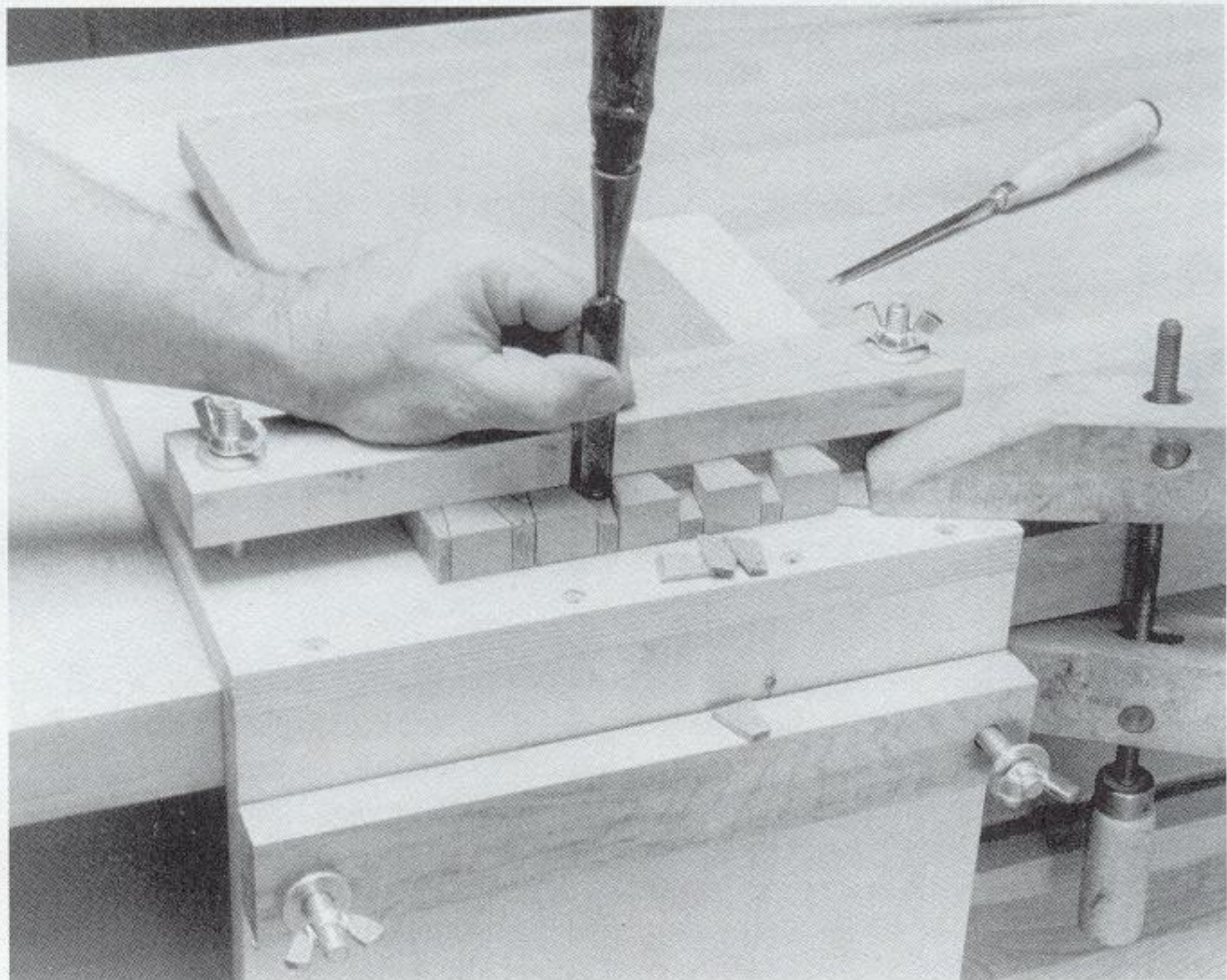

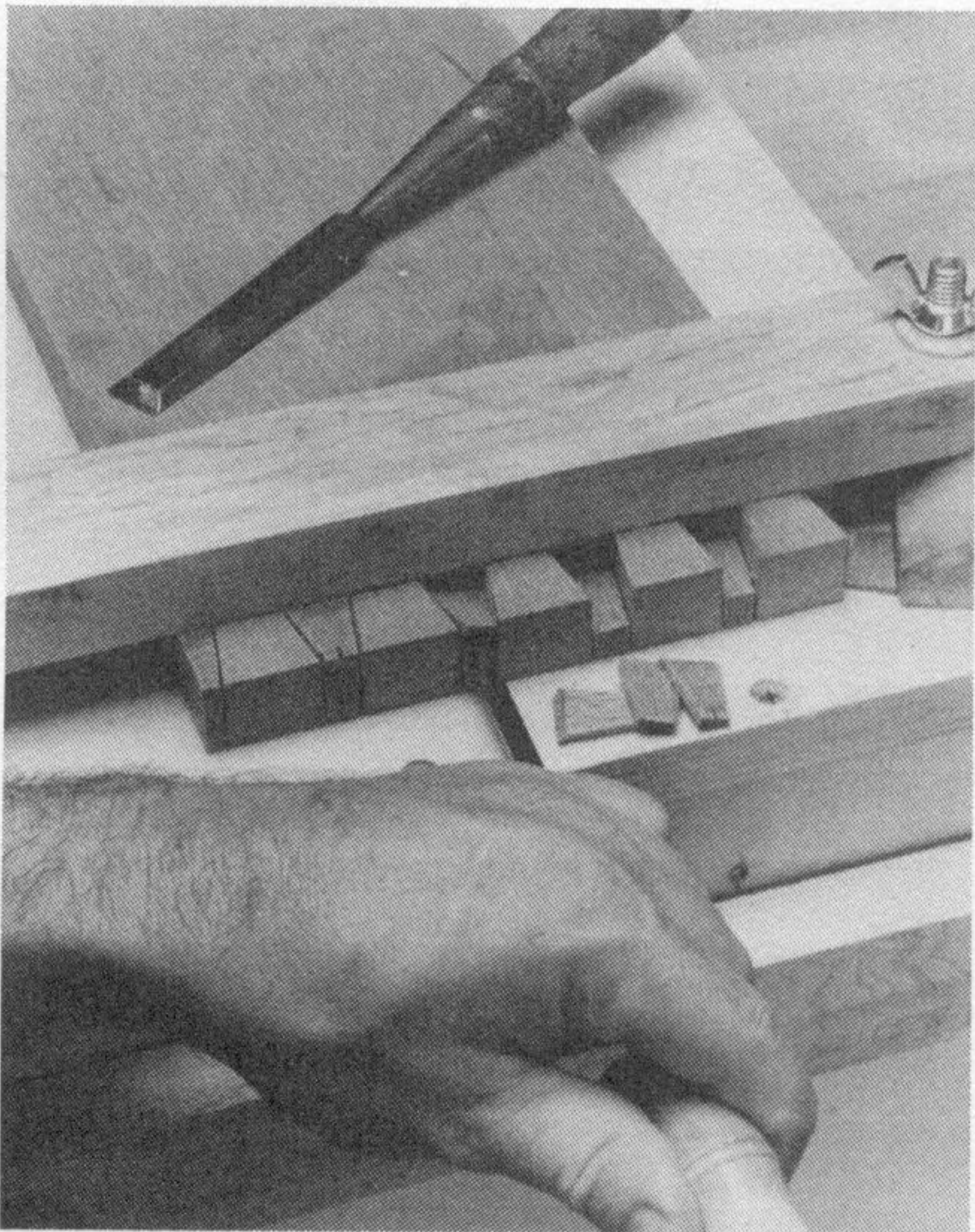

6-15 Next, split out a bit of the waste. Hold the chisel horizontally with its edge against the end and about $\frac{1}{16}$ inch below the surface. Again, strike the chisel lightly with a mallet. This time, it will split out a small amount of waste. Continue cutting and splitting with the chisel until you have removed the waste halfway through the board. Turn the board over and repeat, removing the remaining waste.

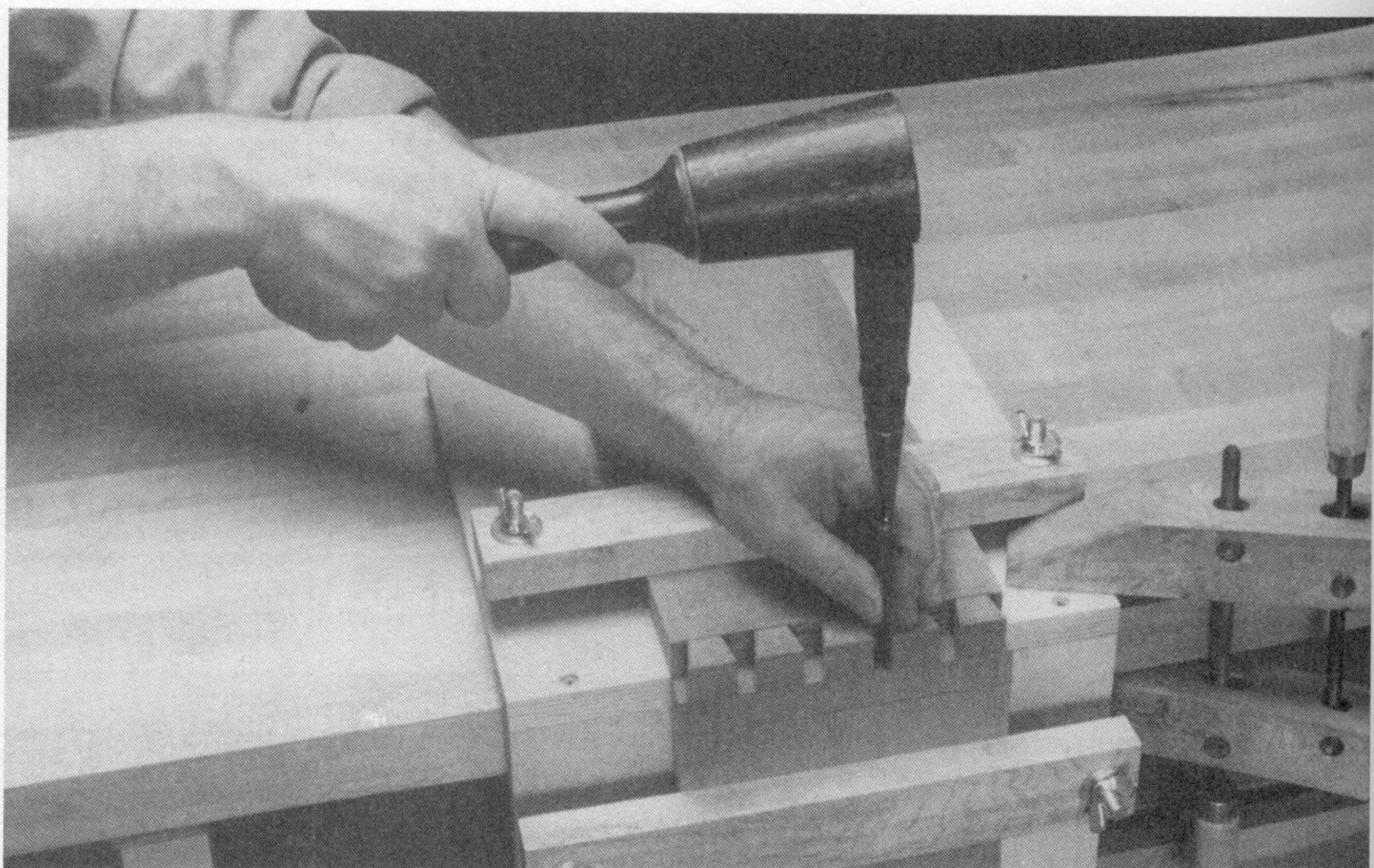

6-16 After cutting the tails, scribe the base of the pins with a marking gauge. (Once again, the pins should be $\frac{1}{32}$ inch longer than the thickness of the adjoining board.) Then use the tails as a template to mark the cheeks of the pins. Clamp the pin board *vertically* in the *Chisel Guide* and the tail board *horizontally*. The tails should cover the end of the

pin board and the surfaces should be flush, as shown. Place the back of a chisel against one of the sloping cheeks of the tails. Tap the chisel with a mallet, cutting about $\frac{1}{32}$ inch into the end of the pin board. Repeat for all the cheeks of all the tails. Remove the board from the *Chisel Guide* and shade the waste between the pins.

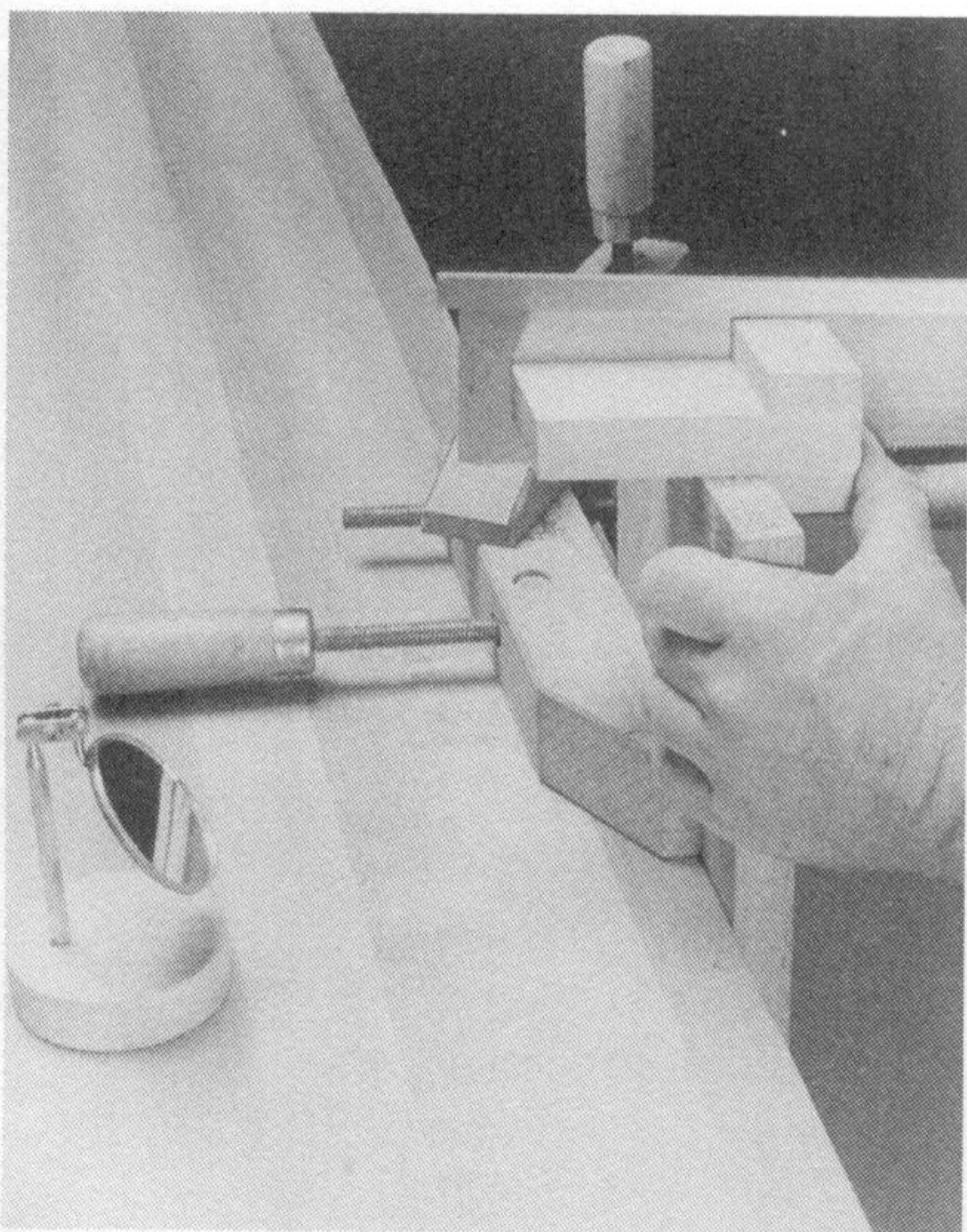

6-17 Cut the cheeks of the pins with a dovetail saw or a dozuki saw. As you did when making the tails, you can use the *Slope Gauge* to start the cut, and the *Third Eye* to monitor the underside of the board as the cut progresses.

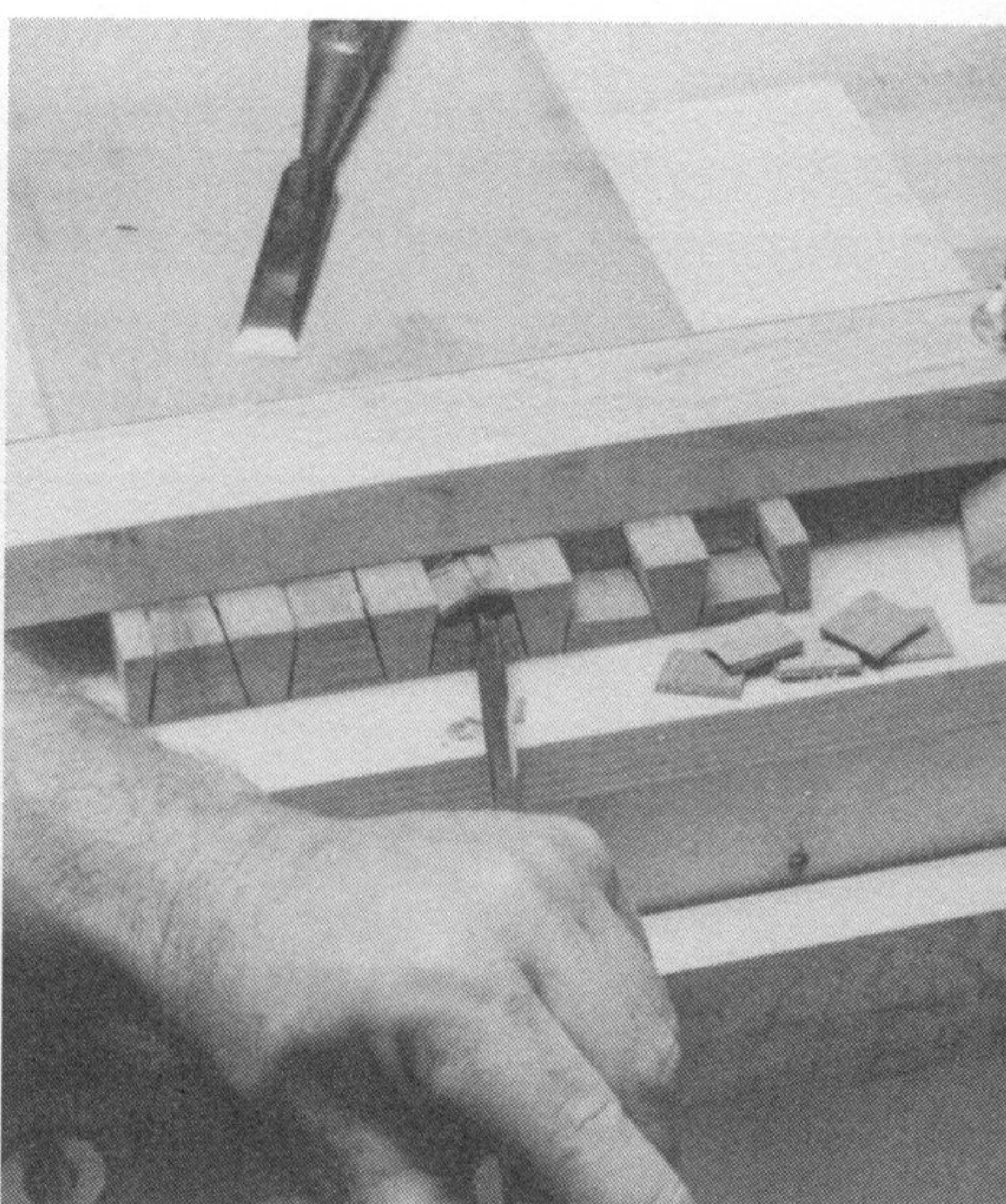

6-18 After cutting the cheeks of the pins, clamp the pin board in the *Chisel Guide*, aligning the guide block with the base layout line. Remove the waste between the pins as you did with the tails, using the chisel alternately as a cutting tool

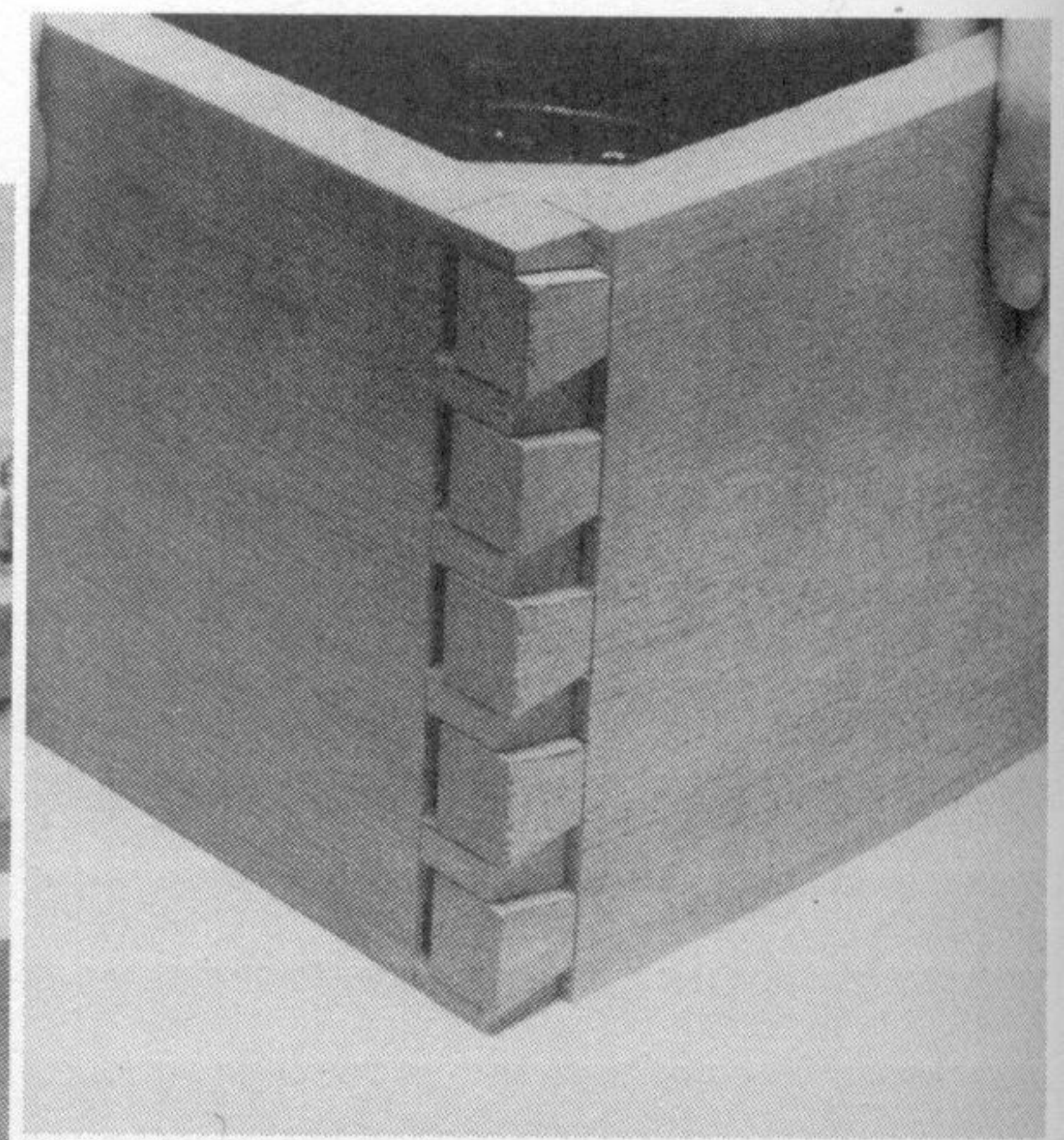

and a wedge. When the waste is gone, fit the joint together. The pins should slide easily between the tails, and the edges of the board should be flush. Sand the protruding ends flush after the joint is assembled.

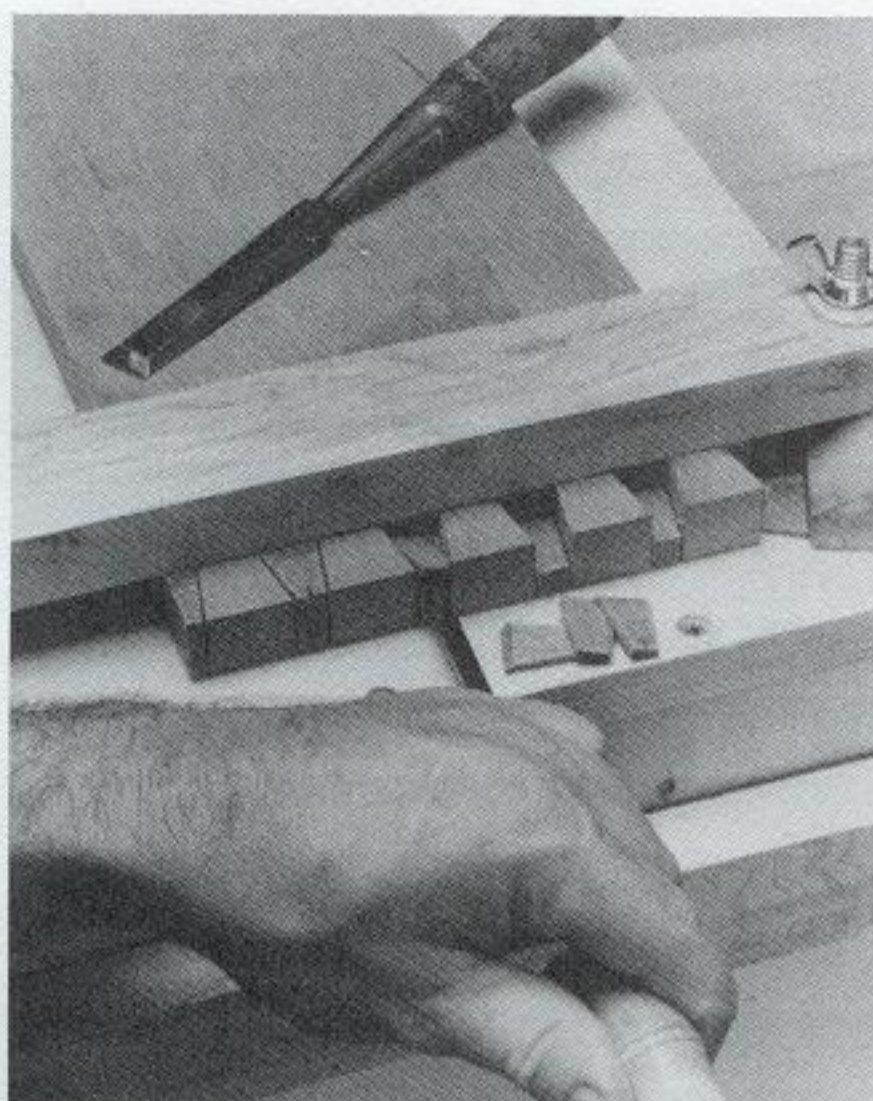

6-15 Next, split out a bit of the waste. Hold the chisel horizontally with its edge against the end and about $\frac{1}{16}$ inch below the surface. Again, strike the chisel lightly with a mallet. This time, it will split out a small amount of waste. Continue cutting and splitting with the chisel until you have removed the waste halfway through the board. Turn the board over and repeat, removing the remaining waste.

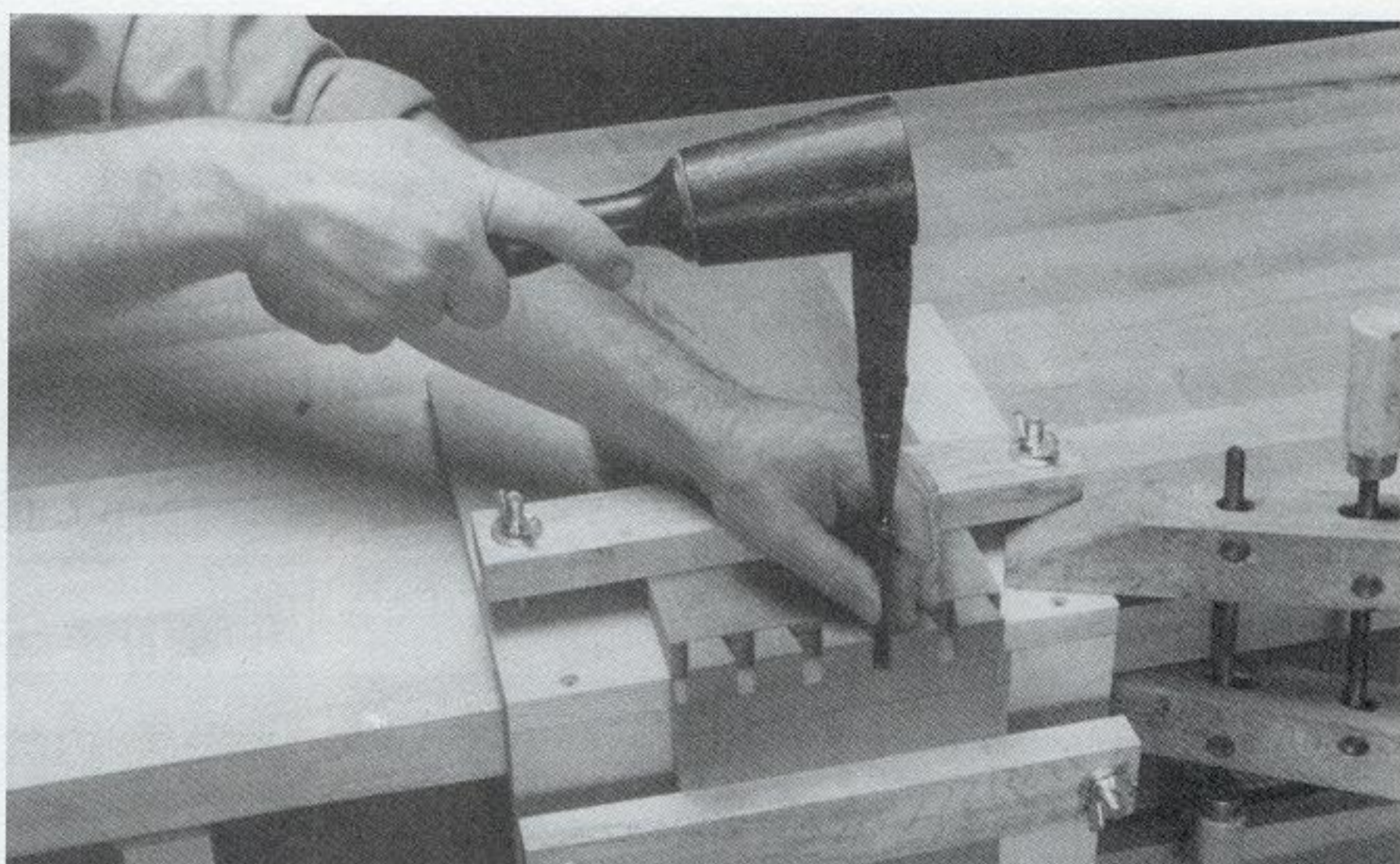

6-16 After cutting the tails, scribe the base of the pins with a marking gauge. (Once again, the pins should be $\frac{1}{32}$ inch longer than the thickness of the adjoining board.) Then use the tails as a template to mark the cheeks of the pins. Clamp the pin board vertically in the *Chisel Guide* and the tail board horizontally. The tails should cover the end of the

pin board and the surfaces should be flush, as shown. Place the back of a chisel against one of the sloping cheeks of the tails. Tap the chisel with a mallet, cutting about $\frac{1}{32}$ inch into the end of the pin board. Repeat for all the cheeks of all the tails. Remove the board from the *Chisel Guide* and shade the waste between the pins.

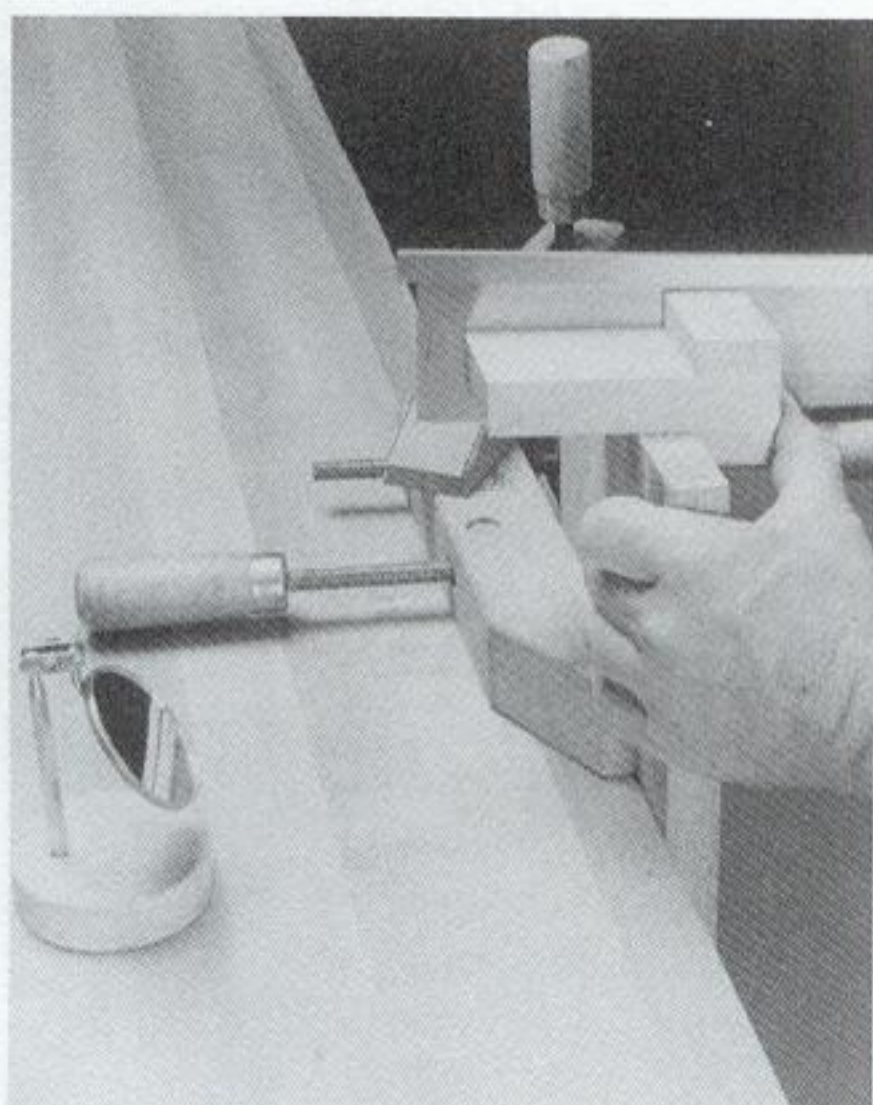

6-17 Cut the cheeks of the pins with a dovetail saw or a dozuki saw. As you did when making the tails, you can use the *Slope Gauge* to start the cut, and the *Third Eye* to monitor the underside of the board as the cut progresses.

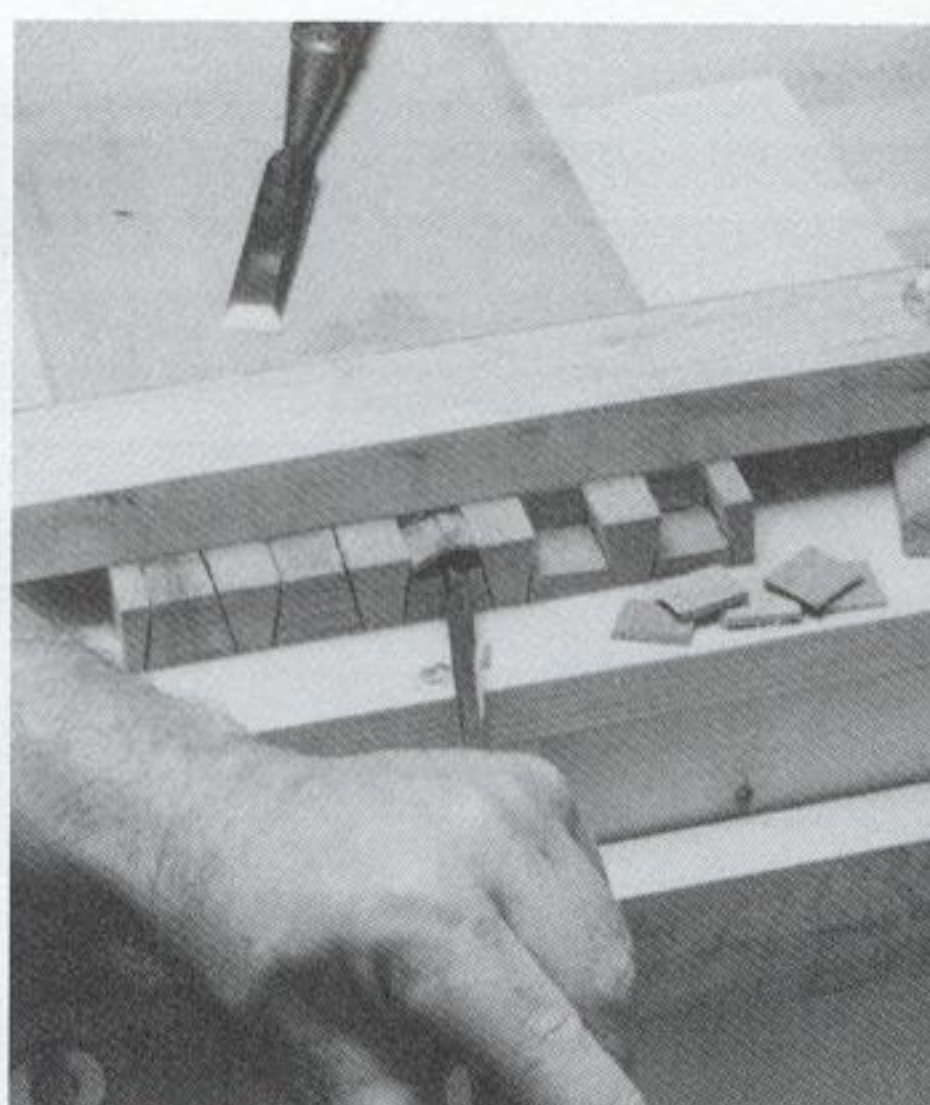

6-18 After cutting the cheeks of the pins, clamp the pin board in the *Chisel Guide*, aligning the guide block with the base layout line. Remove the waste between the pins as you did with the tails, using the chisel alternately as a cutting tool

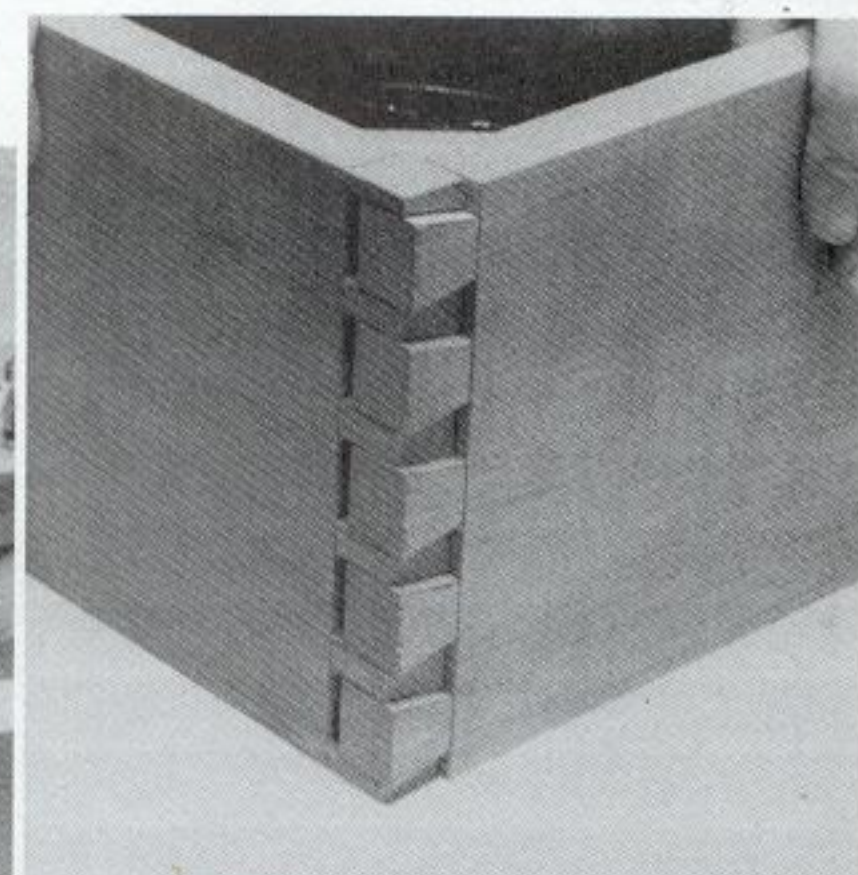

and a wedge. When the waste is gone, fit the joint together. The pins should slide easily between the tails, and the edges of the board should be flush. Sand the protruding ends flush after the joint is assembled.

DOVETAIL AIDS

Here are three easy-to-make jigs that will greatly simplify the task of making hand-cut dovetail joints — a *Layout Rule*, a *Chisel Guide*, and a *Slope Gauge*.

Layout Rule — The rule and holder are used in the same manner as a sliding T-bevel. The rule is marked so you can space the tails evenly and measure the width of the pins. Cut all the parts from hardwood and mark the rule with an awl, indelible ink, or a woodburning tool. Glue the parts of the holder together. Insert the bolt and tighten the nut until the holder will grasp the rule firmly, but not so firmly that the rule becomes immobile.

Chisel Guide — The guide holds the boards while you remove the waste from between the pins

and tails. It also directs the chisel and will keep both boards in proper alignment while you use the tail board to lay out the pin board. Make the guide blocks from hardwood and the horizontal and vertical bases from cabinet-grade plywood. Glue and screw the bases together.

Slope Gauge — This gauge not only marks the slope of the tails and pins, but it will also guide a saw when you start a cut. Before making the gauge, decide on the slope — it should be between 8 and 12 degrees for the joint to be as strong as possible. Cut the parts from hardwood and glue them together. The edges of the ledgers must be precisely parallel.

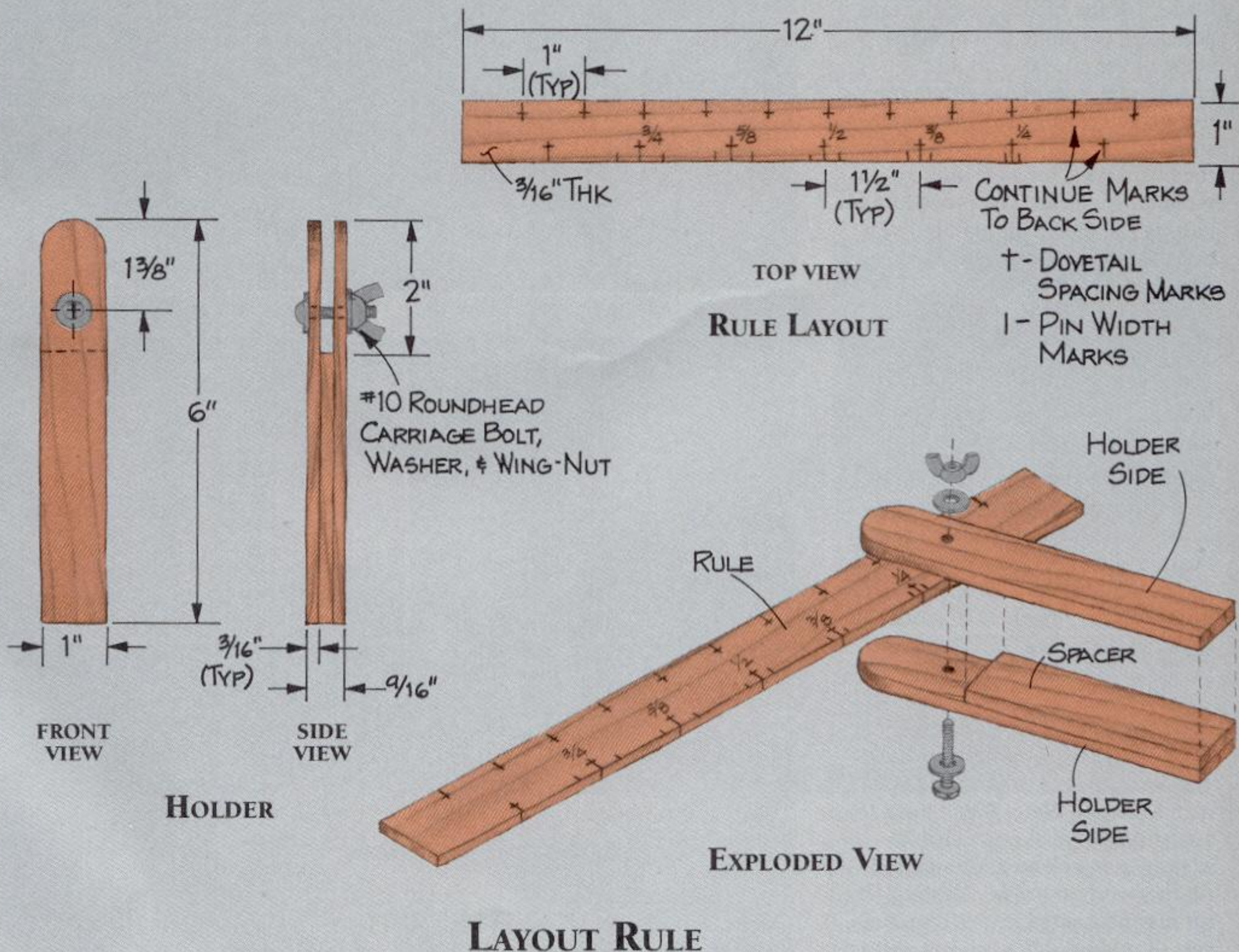

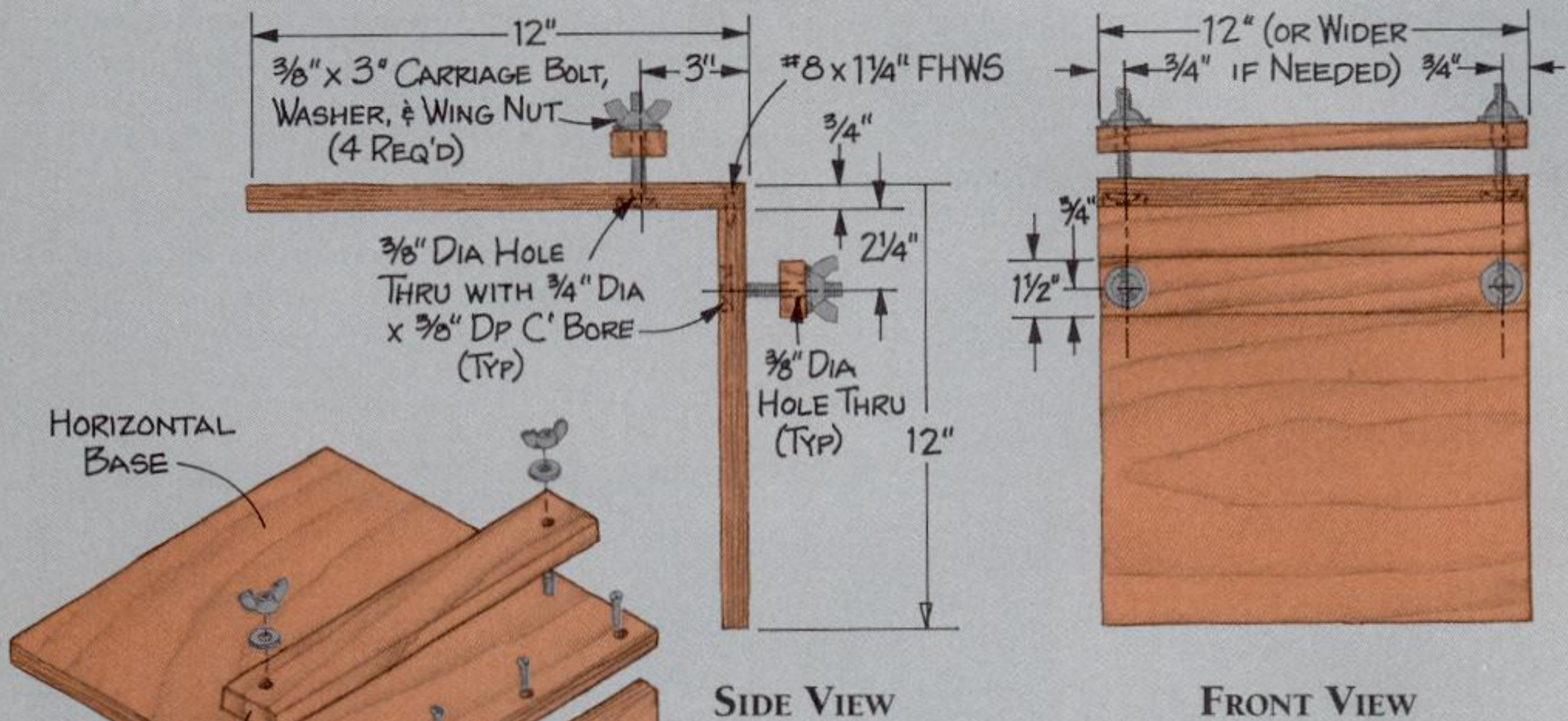

CHISEL GUIDE

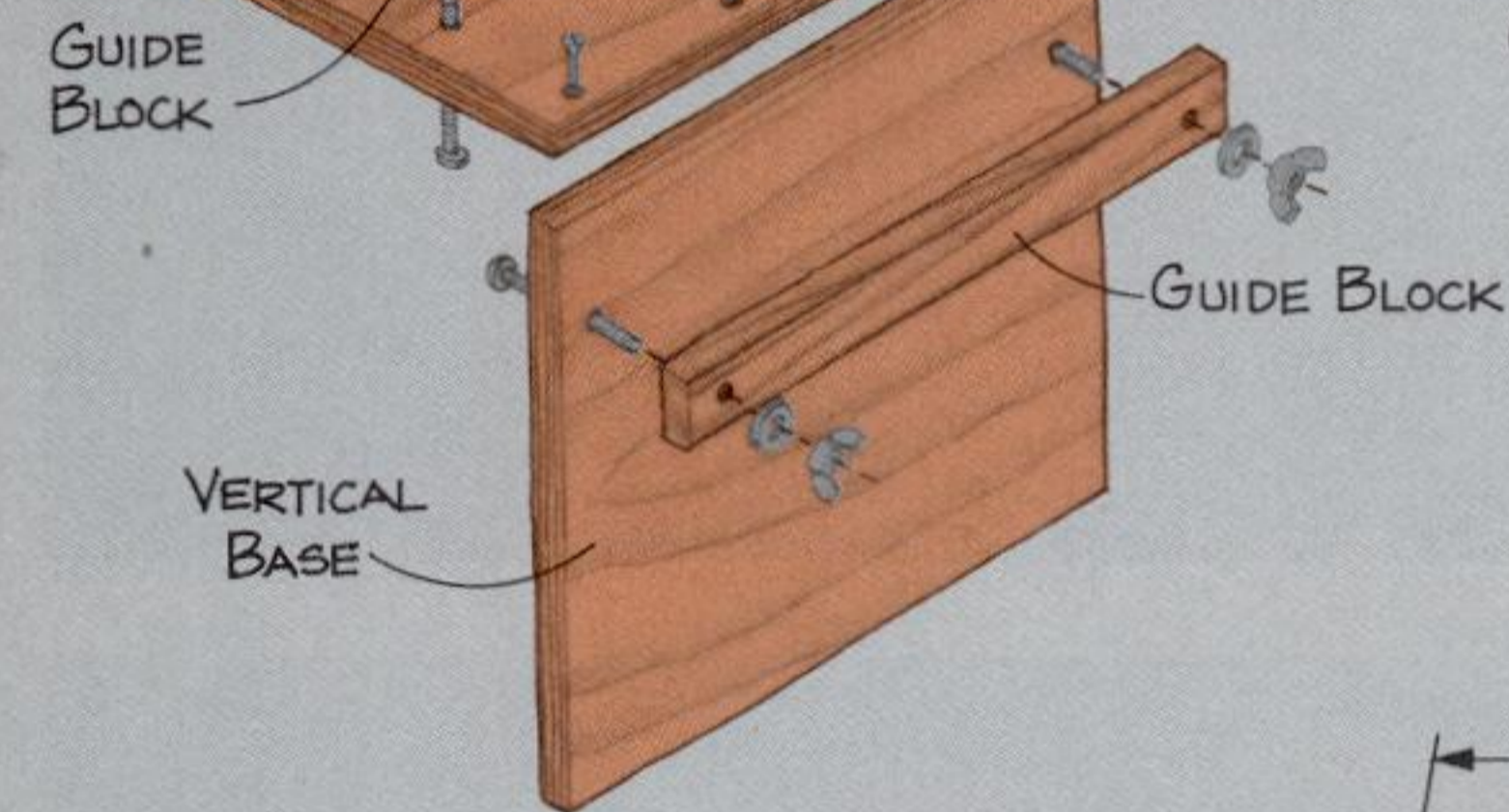

EXPLODED VIEW

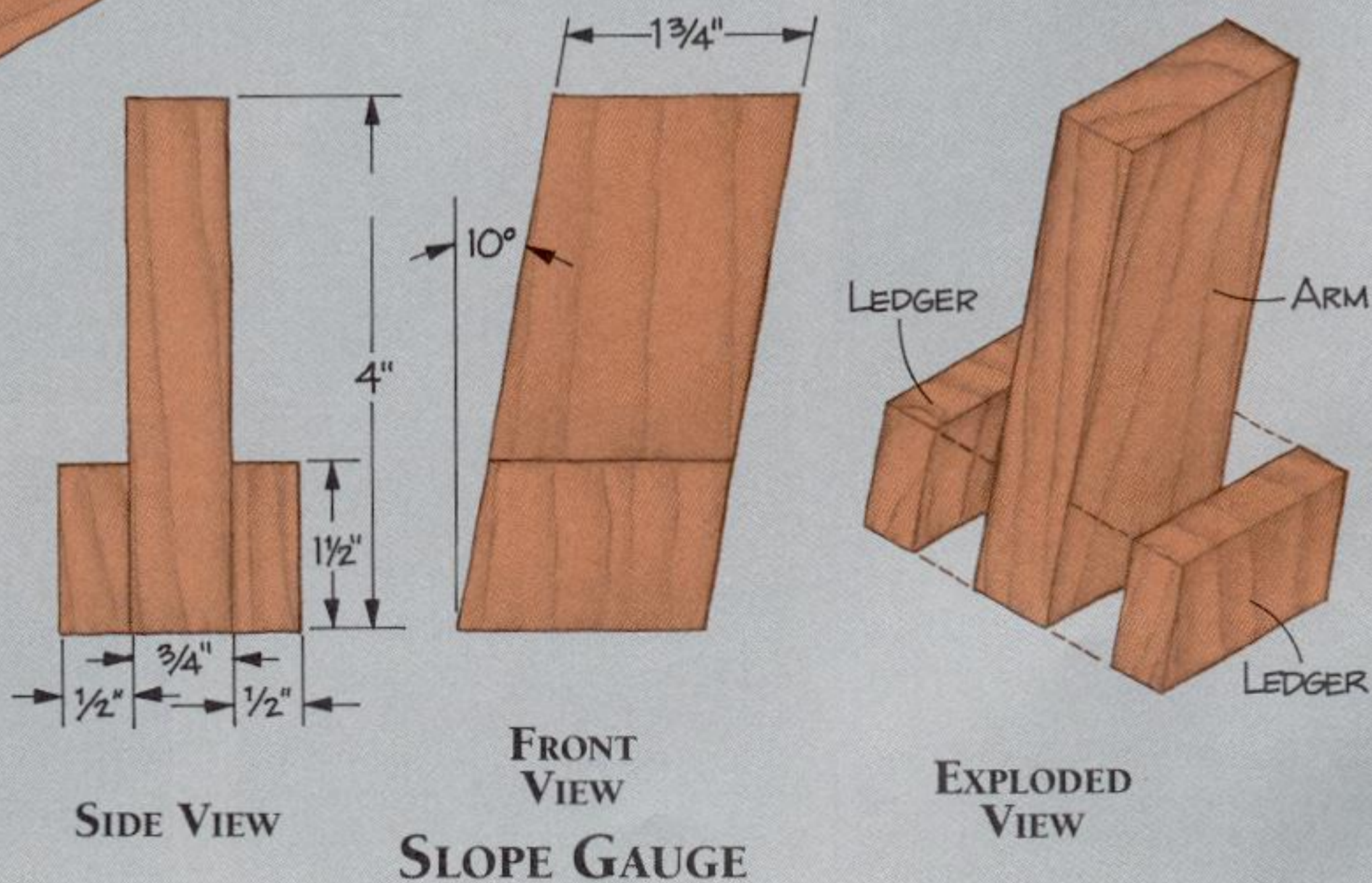

SLOPE GAUGE

HALF-BLIND DOVETAILS

Making half-blind dovetails is similar to making through dovetails. You can use the same jigs for layout and cutting. However, there are two important differences:

- The length of the tails should be no less than one half the thickness of the pin board, but no more than three quarters.

- The notches between the pins must all be cut blind, so you can't see the ends of the tails when the joint is assembled.

Make the tails first, following the same procedures shown in the previous section. (SEE FIGURES 6-7 THROUGH 6-15.) However, you must alter the technique when making the pins. Instead of sawing the cheeks and removing the waste with a chisel, cut the cheeks only partway. Remove as much waste as you can with a drill, then cut away the remaining waste with a chisel. (SEE FIGURES 6-21 THROUGH 6-23.)

6-21 When making the pins of a half-blind dovetail joint, cut the cheeks only *partway* with the saw. Stop cutting when the saw reaches the base of the pins on the *face* of the board, and the bottom of the notches on the *end*.

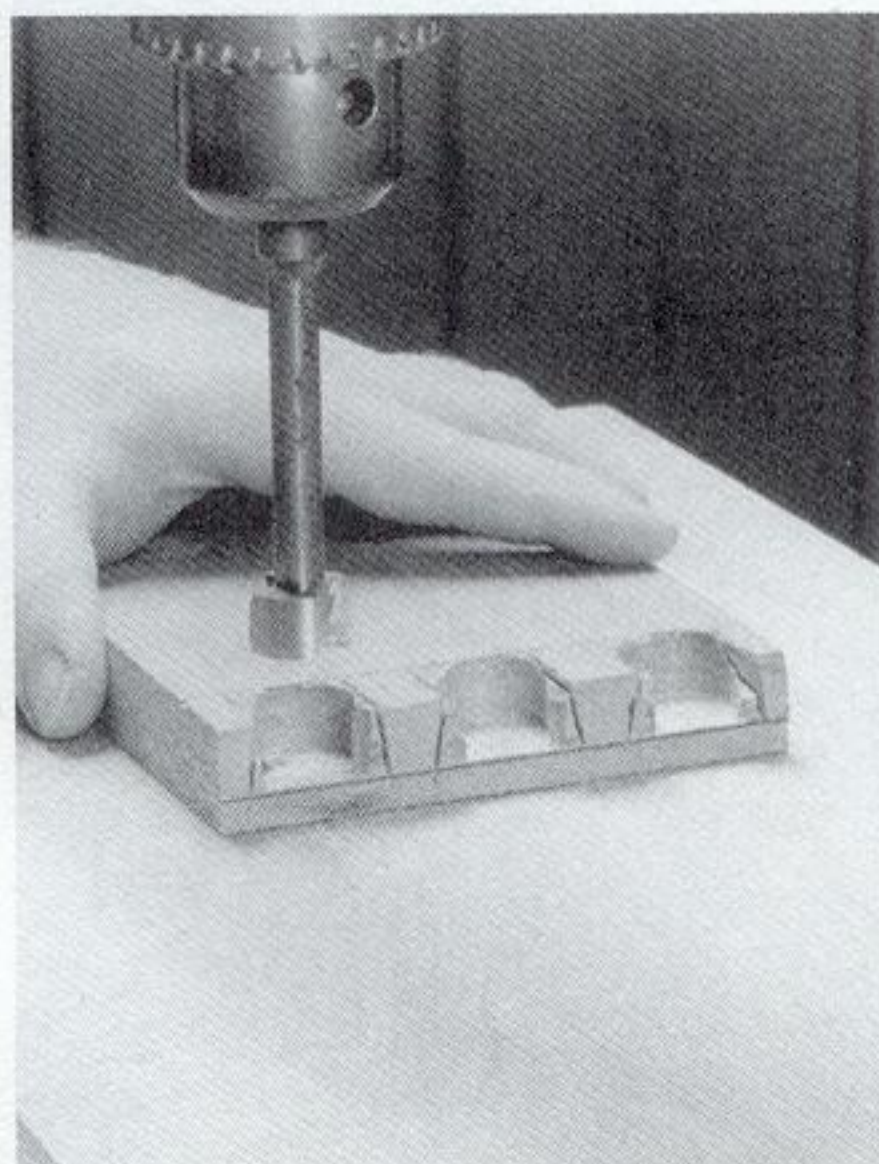
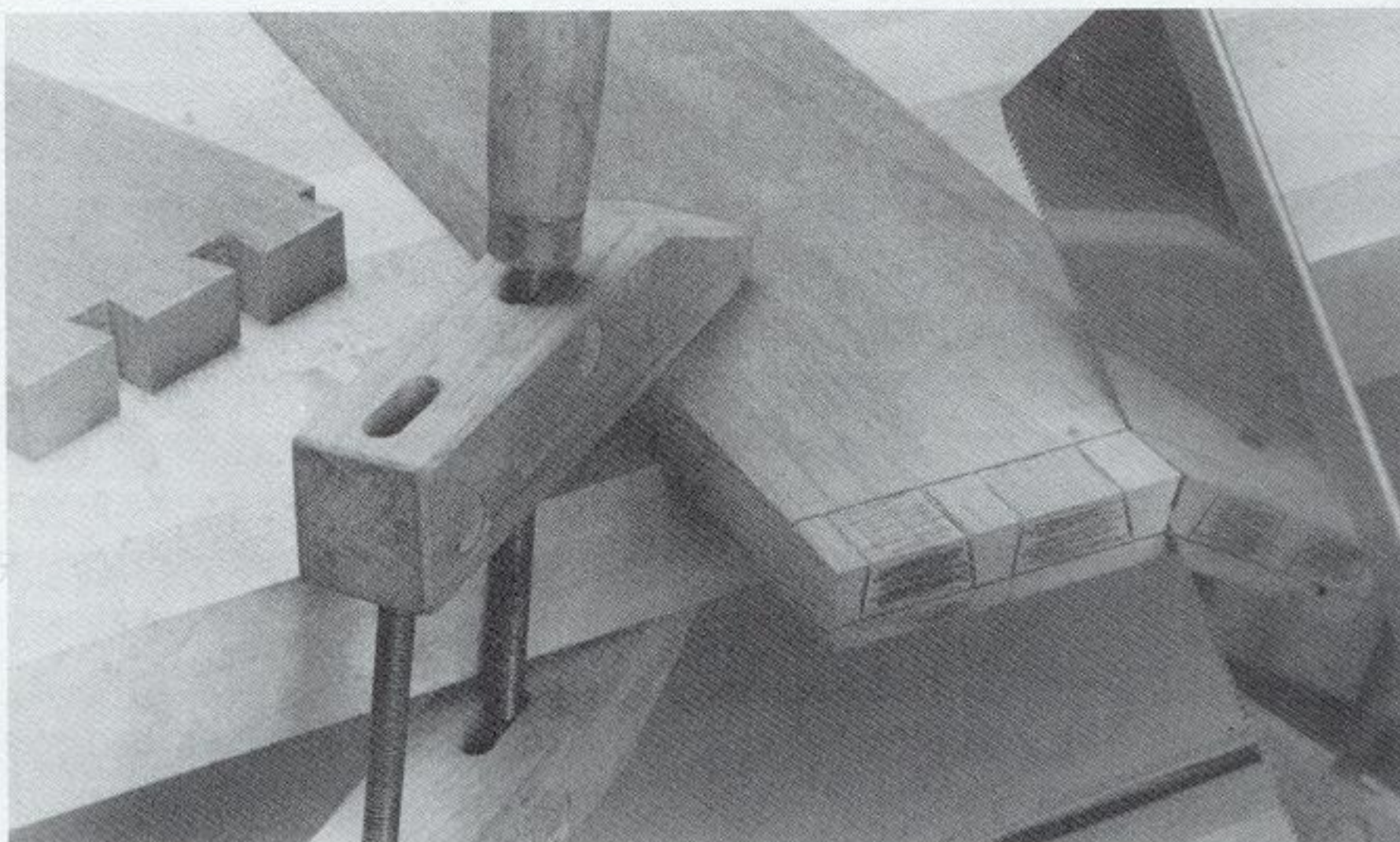

6-22 Remove as much waste as possible from each notch by drilling it out with a Forstner bit. Stop when the bit reaches the bottom of the notch.

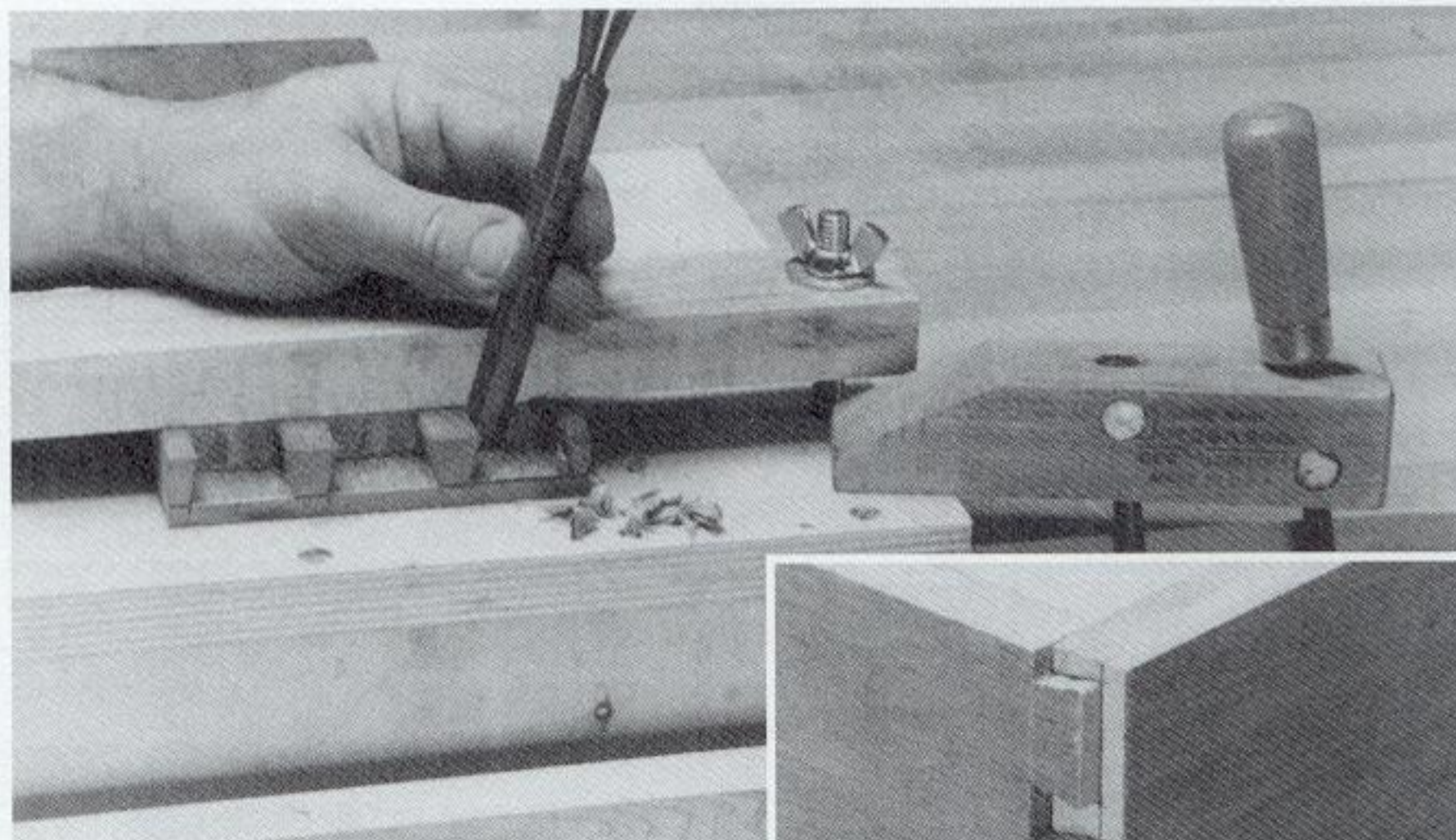

6-23 Remove the remaining waste and finish cutting the pin cheeks with a chisel. As shown previously, use the chisel alternately as a cutting tool and a wedge, cutting down through the grain, then splitting out a small amount of waste.

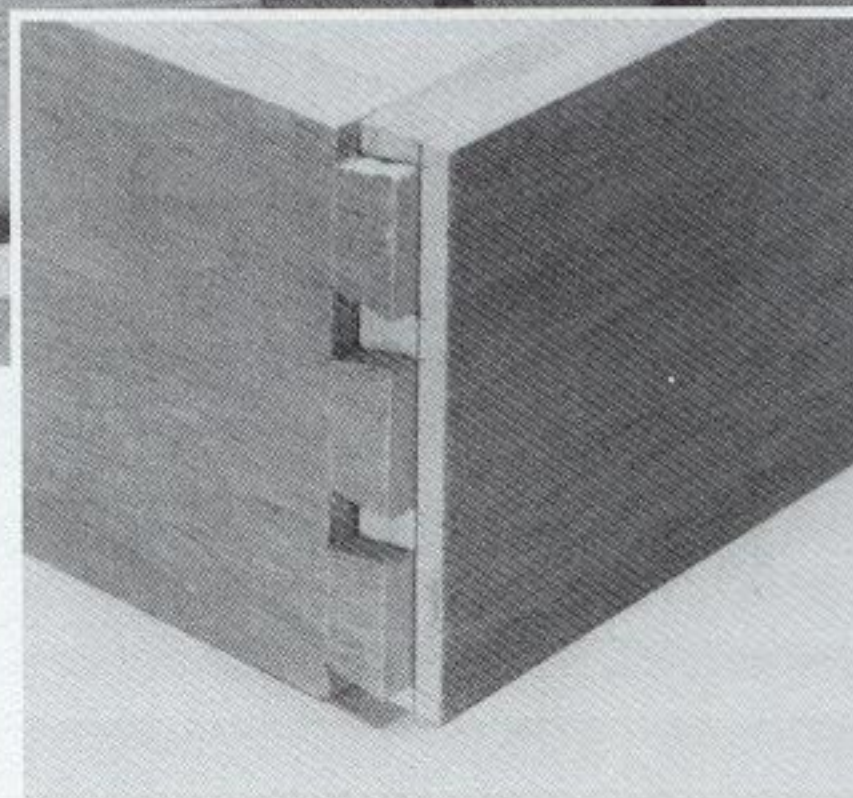



FOR BEST RESULTS

When removing the waste from between the pins of half-blind dovetails, it's difficult to reach into the corners with ordinary paring chisels. Purchase two extra $\frac{1}{2}$ -inch chisels and regrind the cutting edges so each chisel has a 15-degree skew. One chisel should skew to the right, and the other to the left. This will enable you to reach into the corners on *both* sides of each notch. **Note:** Some woodworkers prefer to use a woodcarver's skew chisel or a miniature lathe turner's skew chisel for this task.

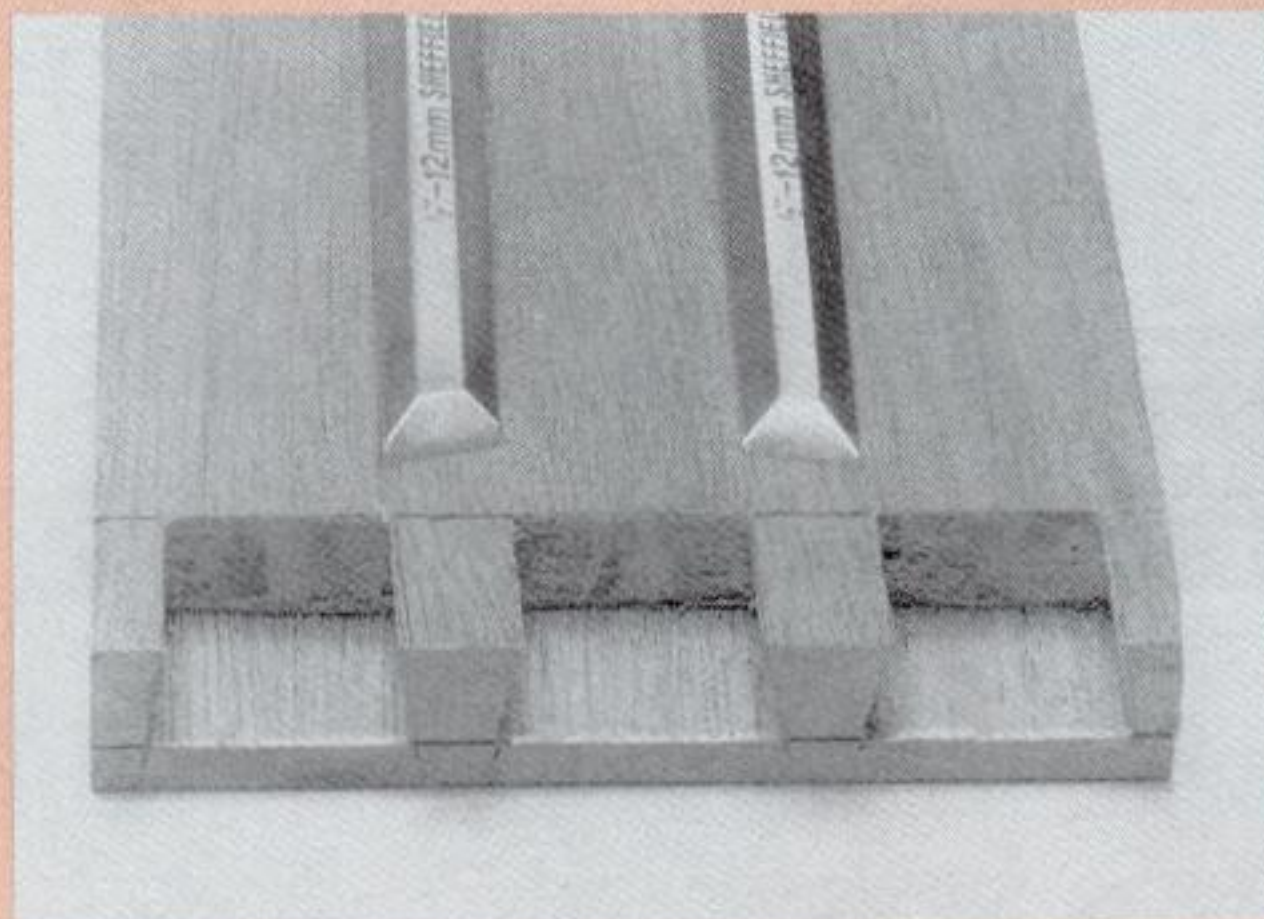

LOCK JOINTS

Like half-blind dovetail joints, lock joints (or locking tongue-and-dado joints) cannot be seen from one direction, and are often used to assemble drawers. They are much easier to make than dovetails — you can cut them with a single setup on a table saw. The trade-off is that they don't withstand shear stress as well as dovetail joints — the wood in front of the dado will shear off if you pull too hard on the drawer front. However, they are still a good choice for small drawers or drawers that won't see much use.

To make a lock joint, mount a dado cutter on a table saw and adjust the depth of cut to equal the thickness of the board. Make a spacer that you can lay over the cutter to quickly reduce the depth of cut.

Using the fence to guide the stock — and without the spacer in place — cut a deep groove in the end of one adjoining board. This groove will create two long tongues. Put the spacer in place and cut the inside tongue short. Then, with the spacer still in place, cut a shallow dado near the end of the other adjoining board. The tongue should fit snugly in the dado. (SEE FIGURES 6-24 THROUGH 6-27.)

Note: As shown, this procedure will create a lock joint in two $\frac{3}{4}$ -inch-thick boards. To join thinner or thicker boards, you must change the width of the dado cutter, the thickness of the spacer, and the location of the fence.

6-24 To make a lock joint in $\frac{3}{4}$ -inch-thick stock, mount a dado cutter on your table saw and adjust it to make a $\frac{1}{4}$ -inch-wide cut. Adjust the depth of cut to $\frac{3}{4}$ inch. Position the fence precisely $\frac{1}{4}$ inch away from the cutter. From a $\frac{1}{2}$ -inch-thick scrap of plywood or hardboard, make a spacer that will fit over the cutter and against the fence, as shown.

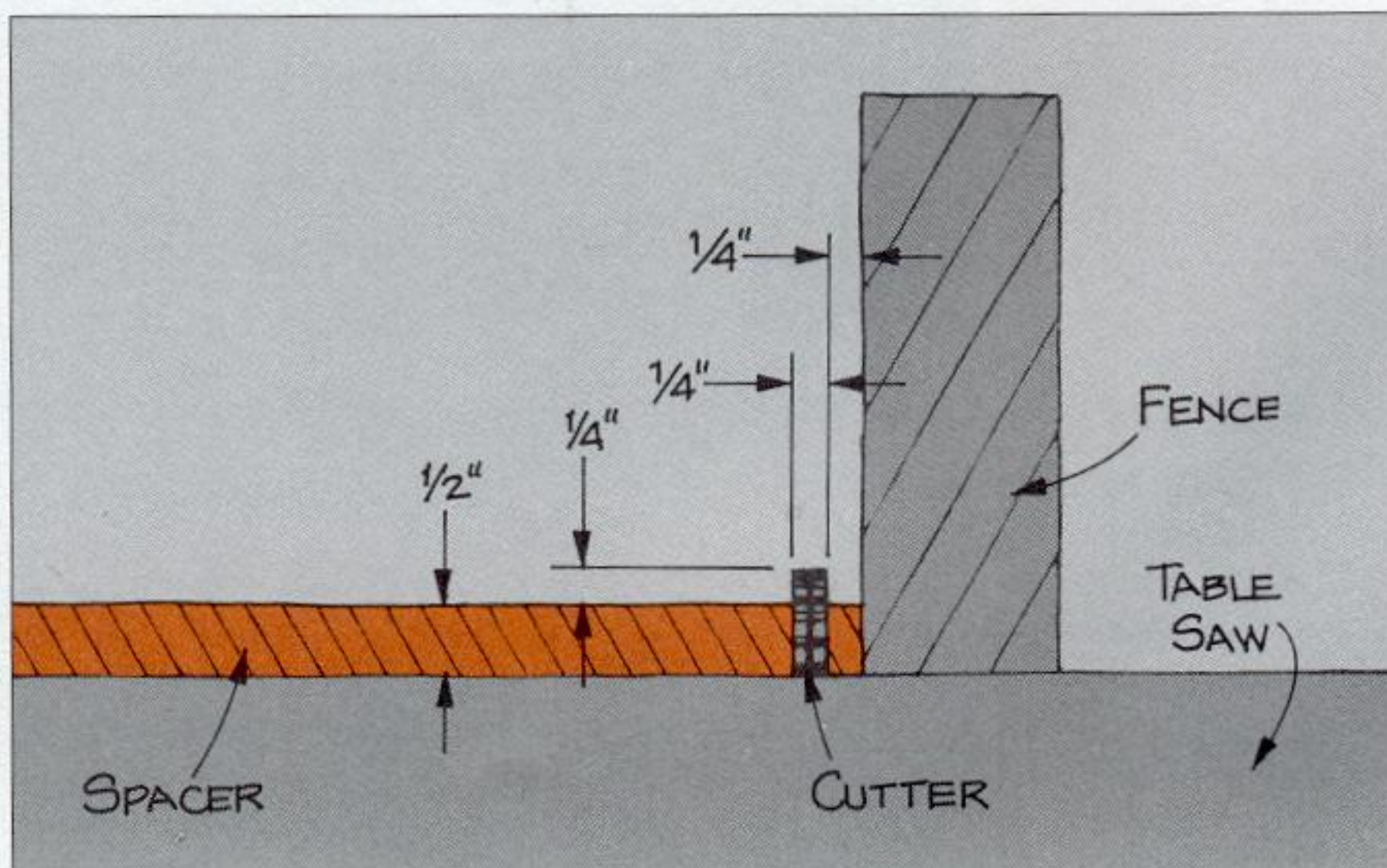

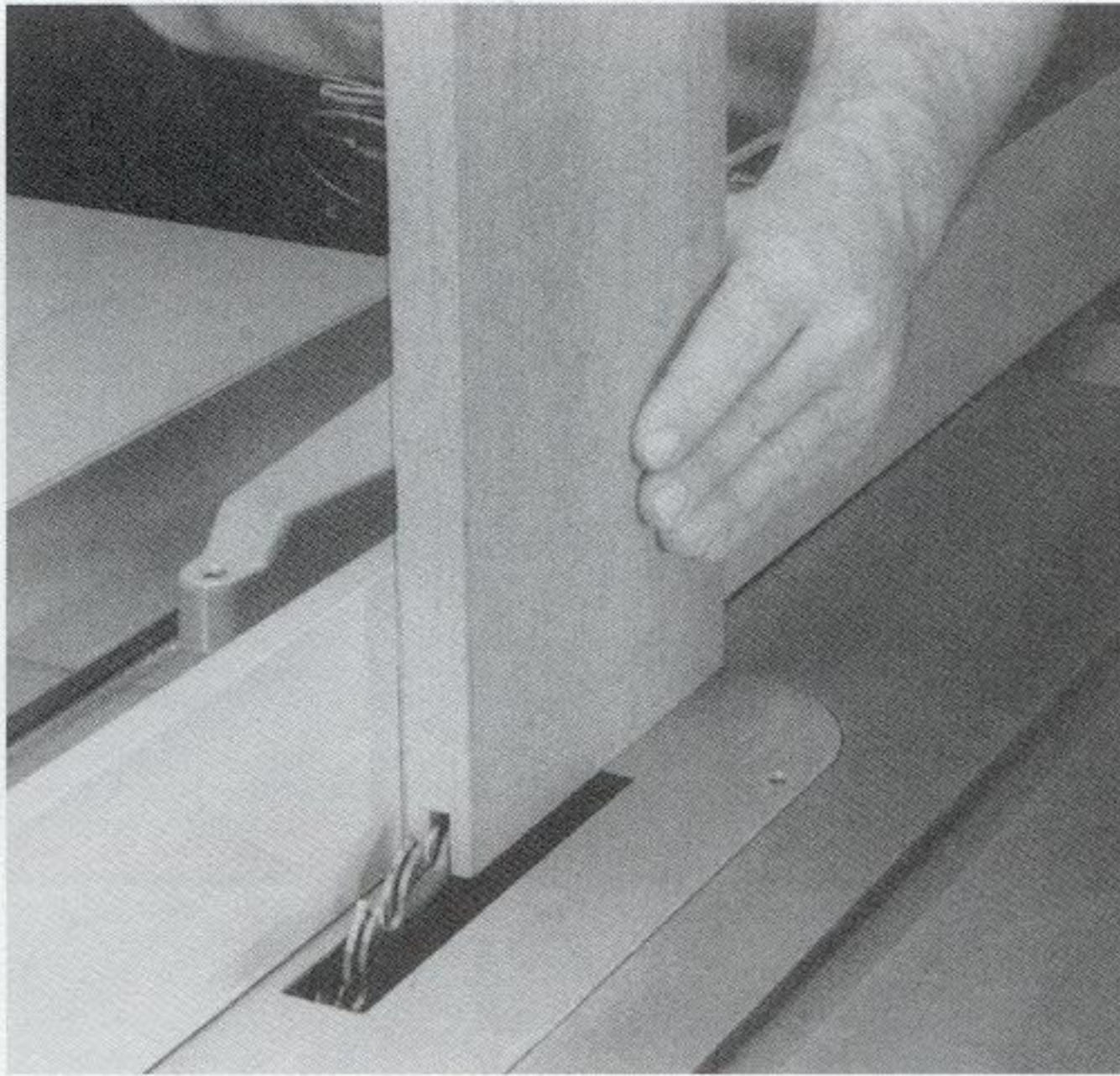

6-25 Without the spacer in place, cut a $\frac{1}{4}$ -inch-wide, $\frac{3}{4}$ -inch-deep groove in the end of one adjoining board. Hold the stock vertically, and use a square scrap of plywood to help guide the stock along the fence. This cut will create two $\frac{1}{4}$ -inch-thick, $\frac{3}{4}$ -inch-long tongues on the end of the board.

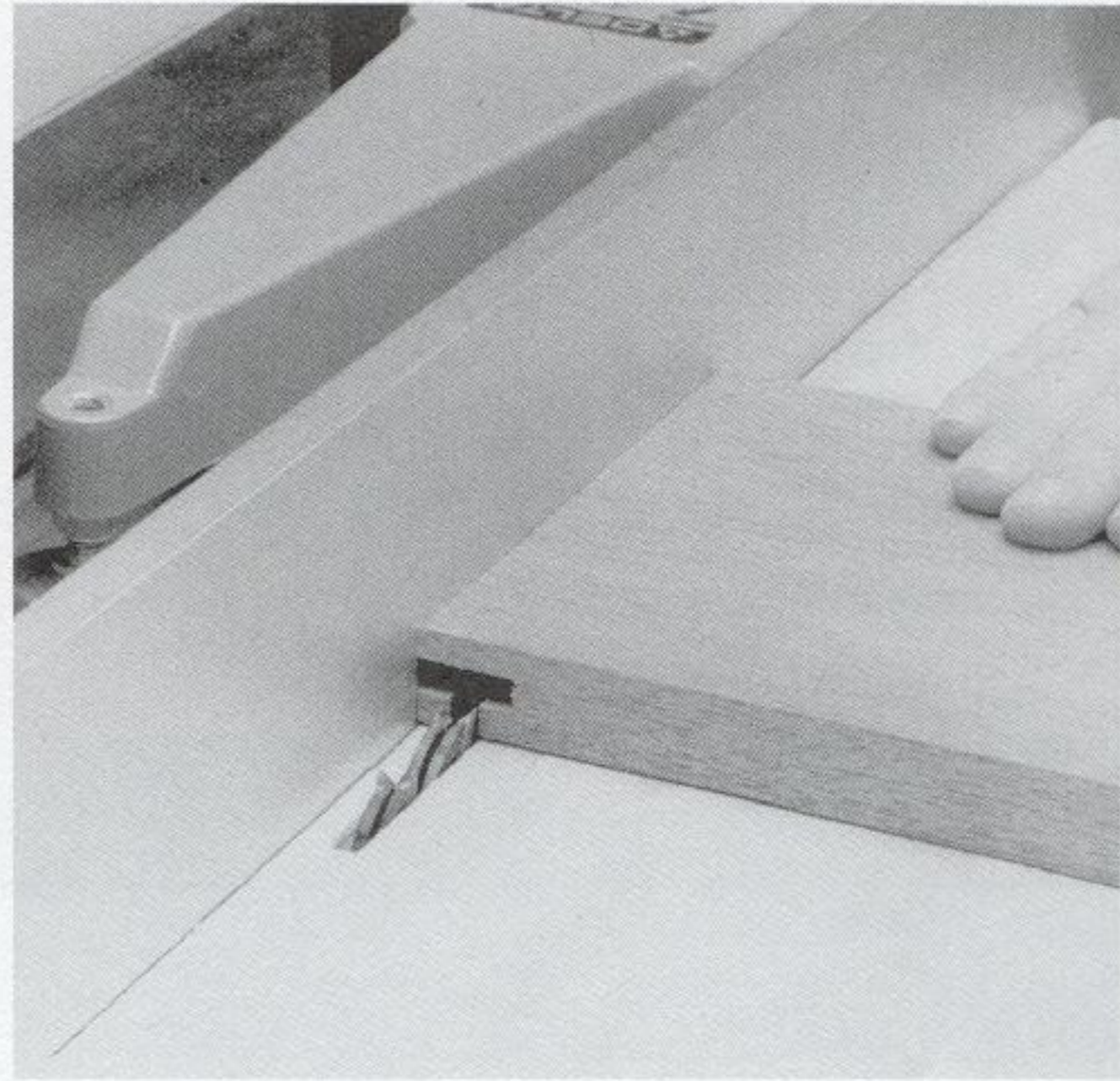

6-26 Put the spacer in place, clamping it to the work surface of the table saw. Holding the stock horizontally with the end against the fence, cut the inside tenon short. Again, use a square scrap of plywood to guide the stock. After making the cut, the short tenon should be just $\frac{1}{4}$ inch long.

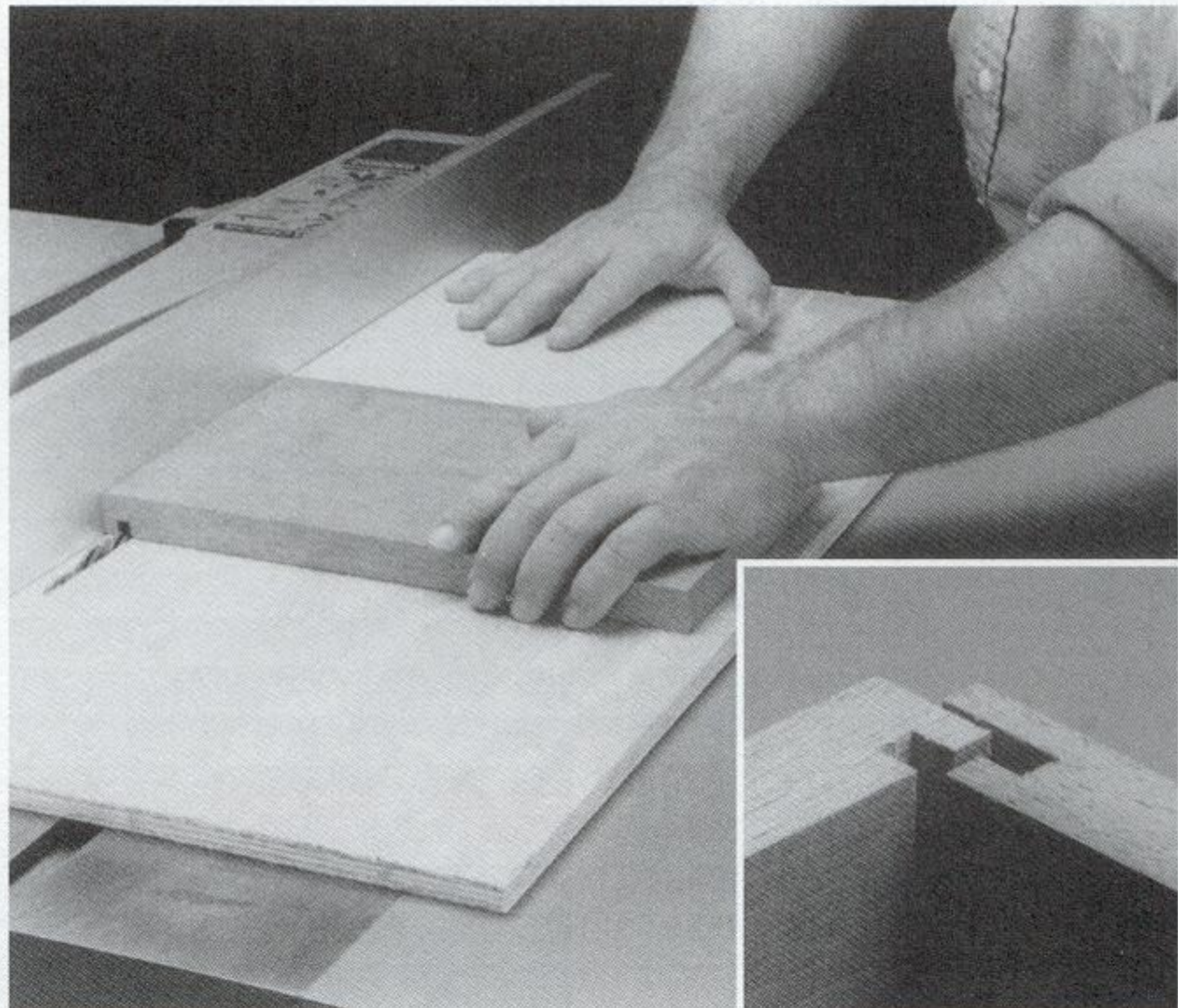

6-27 Leave the spacer in place and cut a $\frac{1}{4}$ -inch-wide, $\frac{1}{4}$ -inch-deep dado in the other adjoining board. As you make the cut, hold the board horizontally with the end against the fence. Again, use the scrap of plywood to guide the stock. When the parts are assembled, the short tongue will fit the dado.

CABINETMAKER'S WORKBENCH

A good, solid workbench requires good, solid joinery. The bench shown was designed to provide a stable work surface for heavy use. The leg assemblies are solidly joined with mortises and tenons, and the cabinet parts with interlocking rabbets, dadoes, and grooves. There is no stretcher; instead, the cabinet is joined to the legs to provide a sturdy base for the benchtop.

This arrangement offers some advantages over more traditional designs. The workbench is easier to build and requires fewer materials than a classic cabinetmaker's workbench. But it is just as strong. And since the bench does not require stretchers or other brace work, there is more space for storage. The cabinet provides both drawers and shelves for small and medium-size tools.

You can use the space between the cabinet and the benchtop for frequently used tools. Because this space is open all around the workbench, you have access to these tools from any location. And this open space makes it simple to mount a vise almost anywhere on the benchtop. You can also attach hold-downs and other bench accessories to the benchtop or frame members.



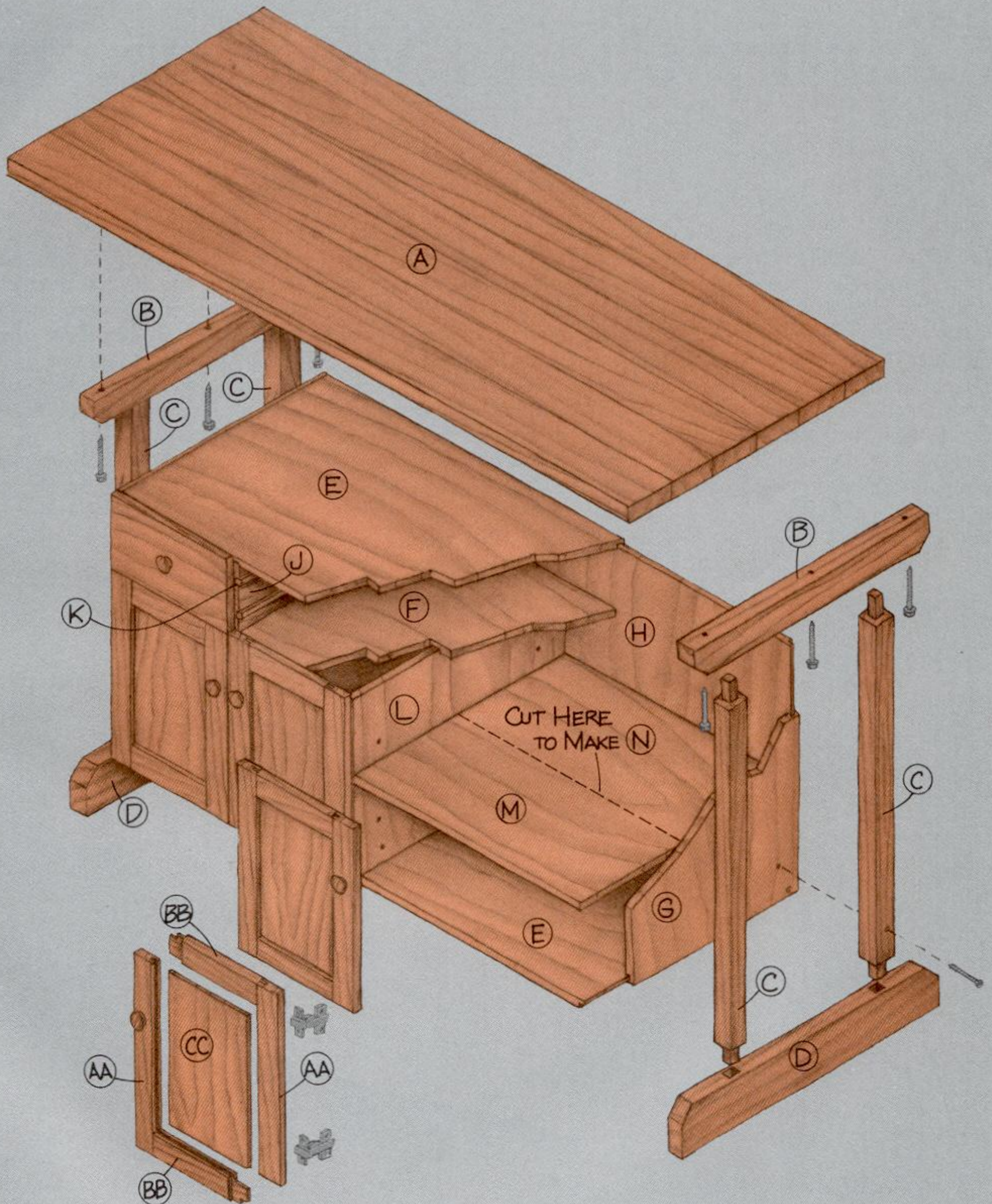

EXPLODED VIEW

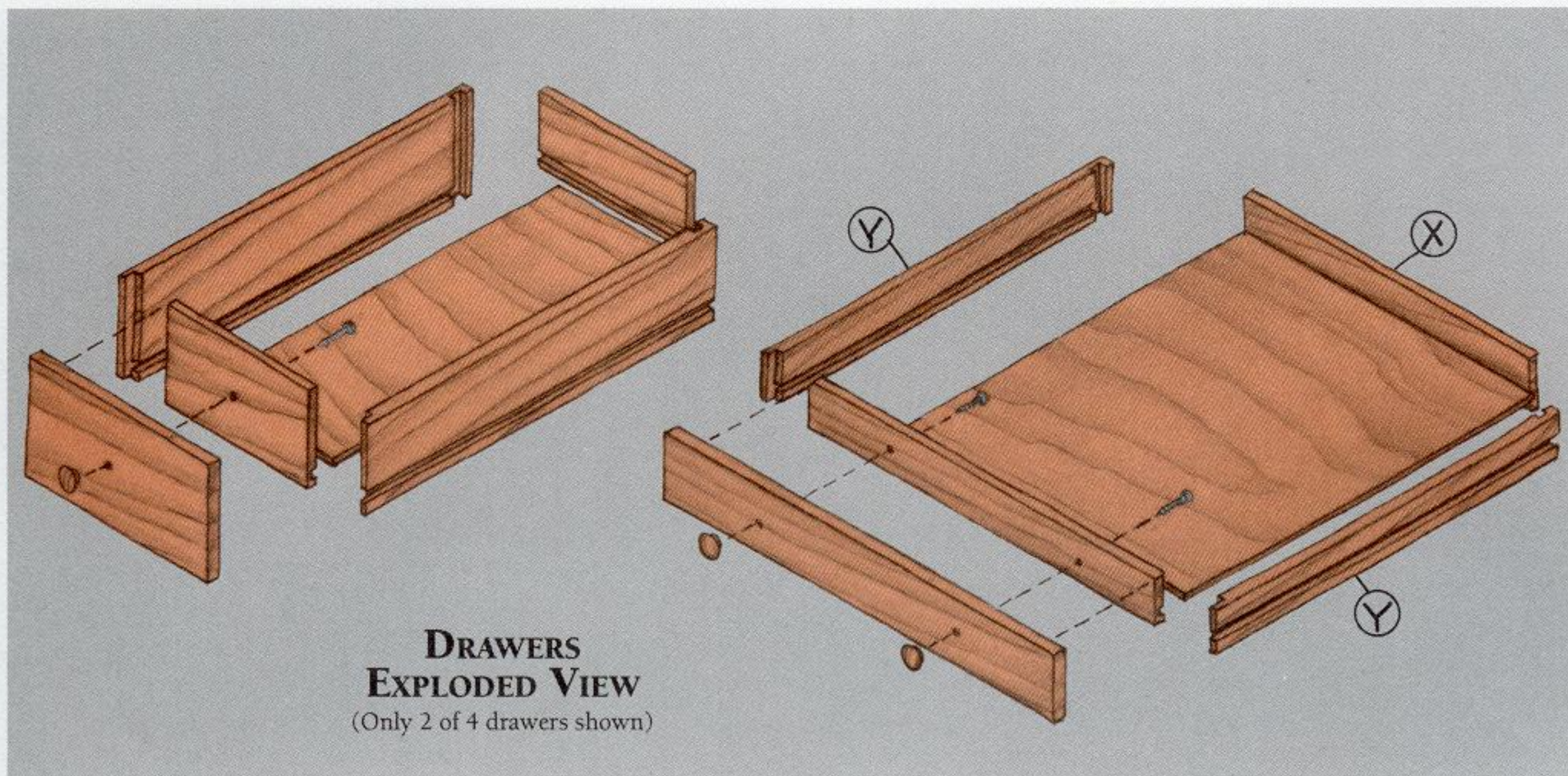

MATERIALS LIST (FINISHED DIMENSIONS)

Parts

Workbench

A. Benchtap*	1½" x 25" x 60"
B. Top braces (2)	1¾" x 2½" x 23"
C. Legs (4)	1¾" x 1¾" x 29½"
D. Feet (2)	1¾" x 3½" x 25"

Cabinet

E. Case top/bottom/shelf† (2)	¾" x 20¼" x 44¼"
F. Fixed shelf†	¾" x 19½" x 44¼"
G. Case sides† (2)	¾" x 20¼" x 22"
H. Case back†	¾" x 21¼" x 44¼"
J. Drawer dividers† (2)	¾" x 6" x 19½"
K. Drawer guides (8)	½" x ½" x 19½"
L. Cupboard divider†	¾" x 15¼" x 19½"
M. Adjustable shelf†	¾" x 19¼" x 21¼"
N. Adjustable half-shelf†	¾" x 11" x 21¼"

Drawers

P. End drawer faces (2)	¾" x 6" x 11¼"
Q. End drawer fronts/back (4)	½" x 5⅜" x 9½"
R. End drawer sides (4)	½" x 5⅜" x 19½"
S. End drawer bottoms† (2)	¼" x 9½" x 18½"
T. Shallow middle drawer face	¾" x 2¾" x 22½"
U. Shallow middle drawer front/back (2)	½" x 1⅝" x 21⅞"
V. Shallow middle drawer sides (2)	½" x 1⅝" x 19½"
W. Deep middle drawer face	¾" x 3¼" x 22½"
X. Deep middle drawer front/back (2)	½" x 3⅜" x 21⅞"
Y. Deep middle drawer sides (2)	½" x 3⅜" x 19½"
Z. Middle drawer bottoms† (2)	¼" x 18½" x 21⅞"

Doors

AA. Stiles (8)	¾" x 2" x 16"
BB. Rails (8)	¾" x 2" x 9¾"
CC. Door panels† (4)	¼" x 8" x 12¾"

*This is a standard-size solid maple "butcherblock" countertop, which you can purchase from many lumberyards on special order.

†Make these parts from plywood.

Hardware

⅜" x 3½" Lag screws (6)
#8 x 1¼" Flathead wood screws (48-60)
#12 x 2" Flathead wood screws (12)
1" Brads (24-36)
⅜" Flat washers (6)
1¼" Drawer/door pulls (10)
European-style full overlay hinges (8)
¼" dia. Shelving support pins (8)

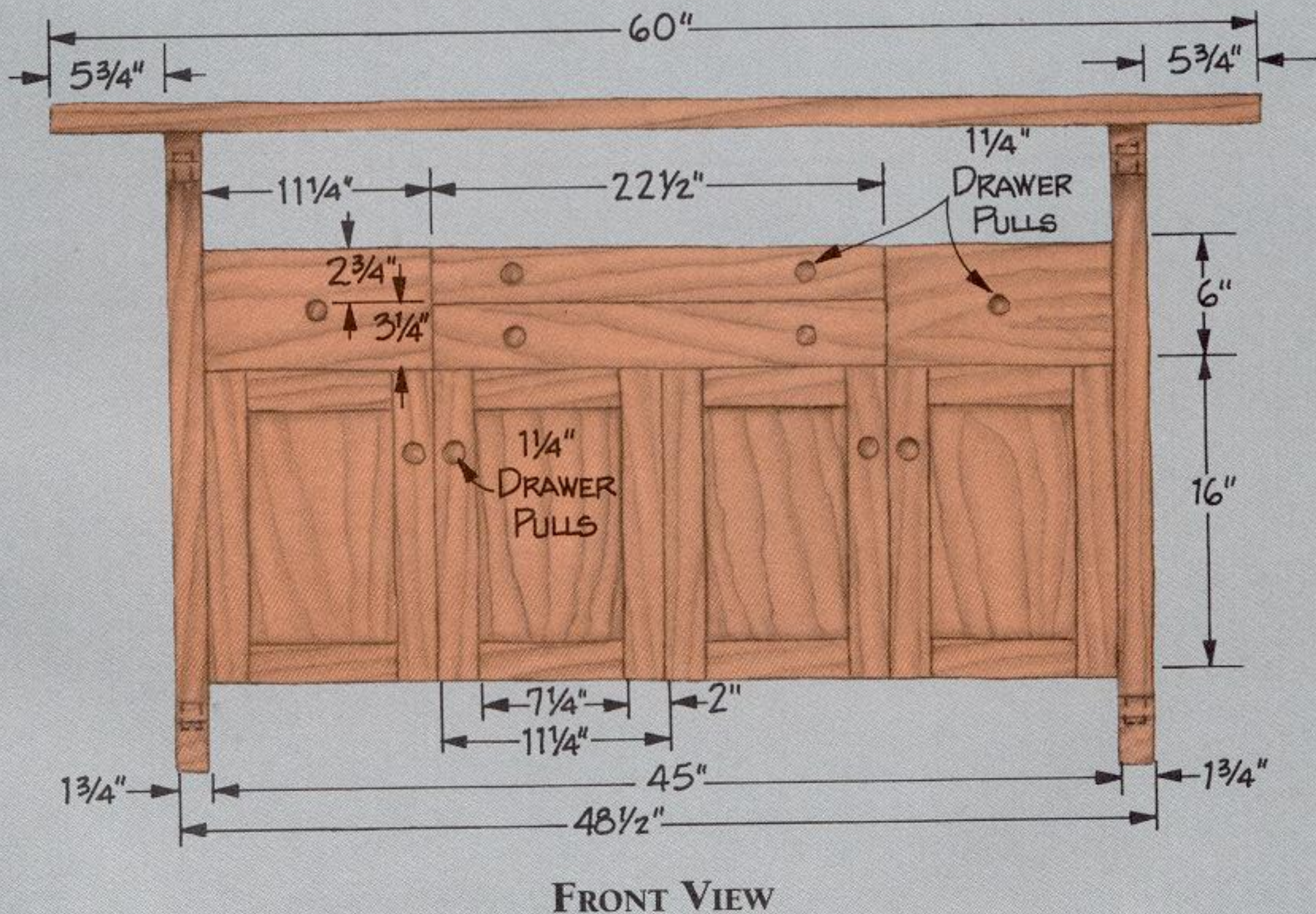
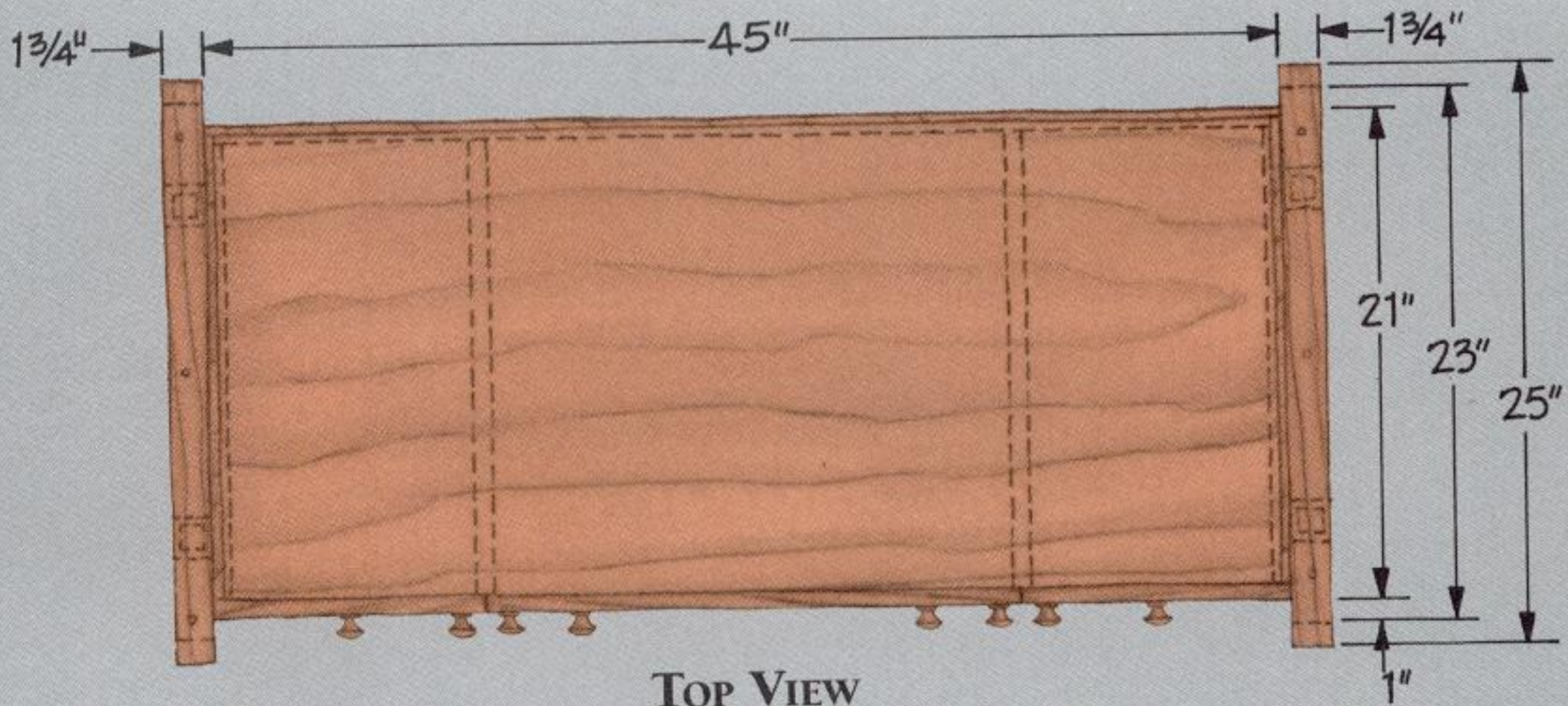

PLAN OF PROCEDURE

1 Select the stock and cut the parts to size. To make this workbench, you need about 34 board feet of 8/4 (eight-quarters) stock, 15 board feet of 4/4 (four-quarters) stock, two 4 x 8-foot sheets of cabinet-grade 3/4-inch plywood, and one 4 x 4-foot sheet of cabinet-grade 1/4-inch plywood. (If you purchase the benchtop ready-made, you'll need only 14 board feet

of 8/4 stock.) All the solid stock should be a hardwood, such as birch, maple, or oak, and the plywood veneer should either match or complement the solid wood. The workbench shown is made from maple and birch-veneer plywood.

Plane the 8/4 stock to 1 3/4 inches thick and cut the top braces, legs, and feet. Set some 1 3/4-inch-thick

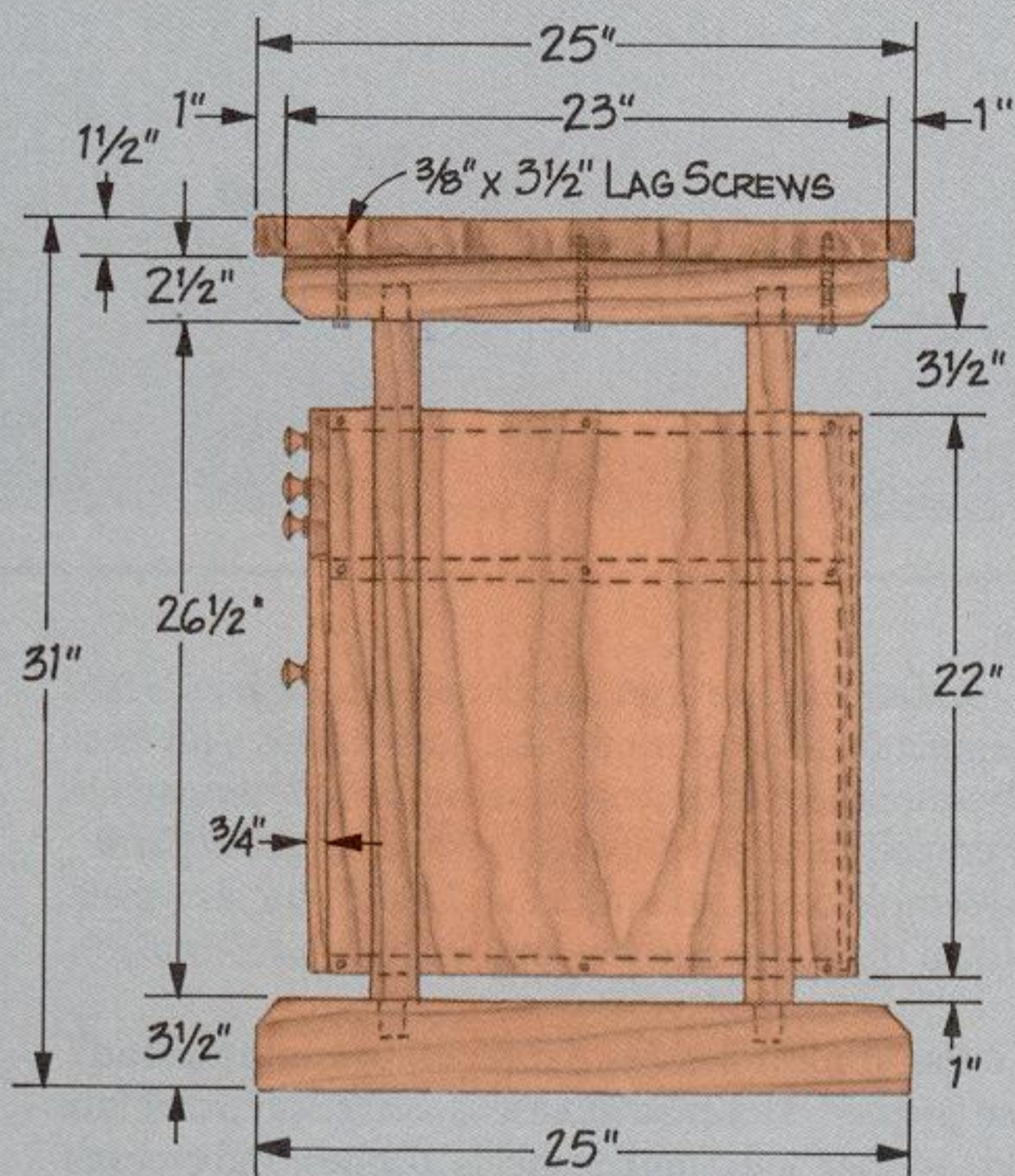

SIDE VIEW

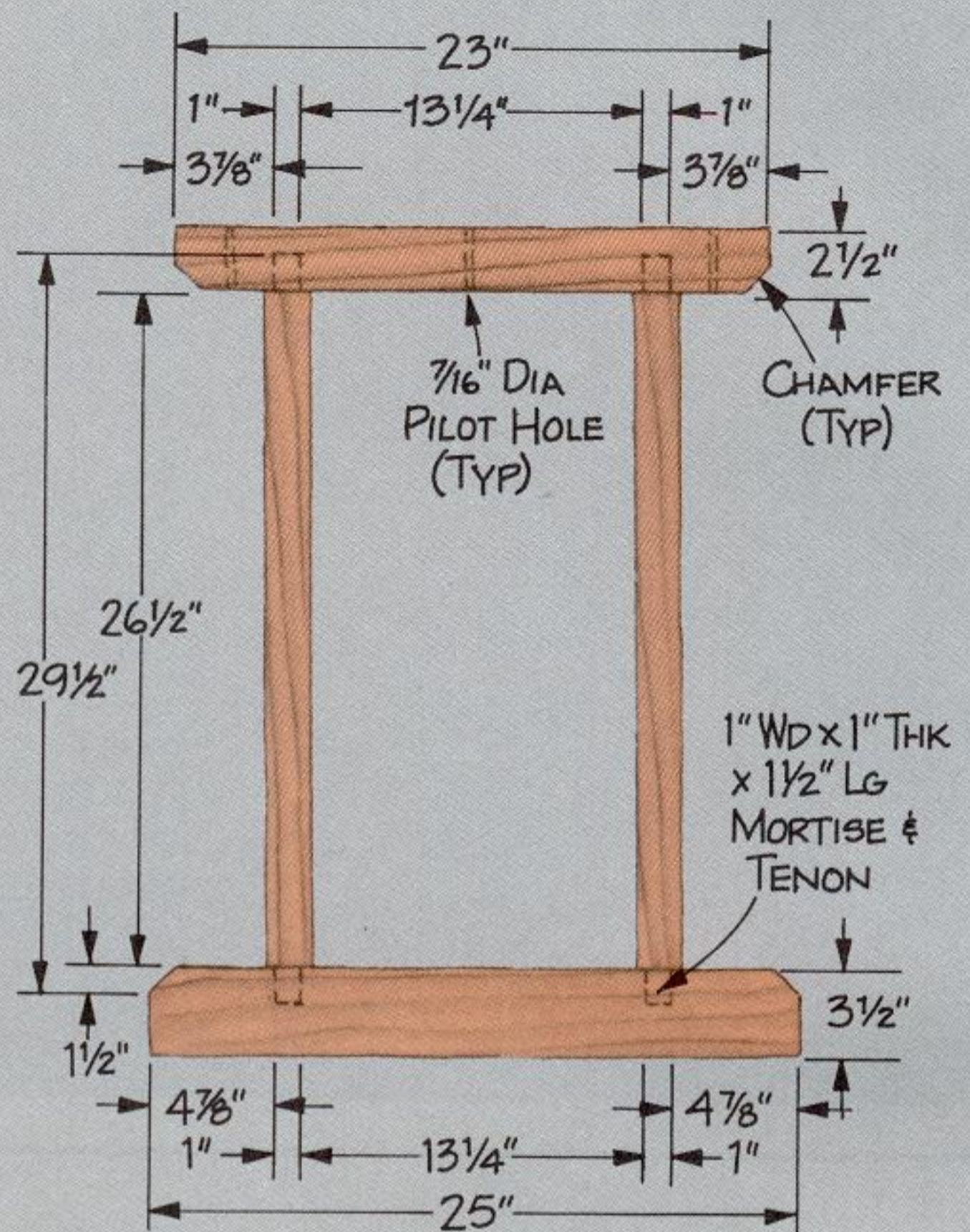

LEG ASSEMBLY LAYOUT

stock aside to use as test pieces, then plane the remaining stock to 1 1/2 inches thick. Cut this into 1 1/2-inch-wide strips. Glue these strips edge to edge to make the benchtop. Be sure to orient these strips so the annual rings run top to bottom, as shown on page 9. This will reduce the amount of swelling and shrinking across the width of the bench.

Plane the 4/4 stock to 3/4 inch thick and cut the rails, stiles, and drawer faces. Set some of the 3/4-inch-thick stock aside to use as test pieces, then plane the remaining stock to 1/2 inch thick. Cut the drawer guides, fronts, backs, and sides.

Finally, cut the plywood parts to size. Clearly label all the parts as you cut them.

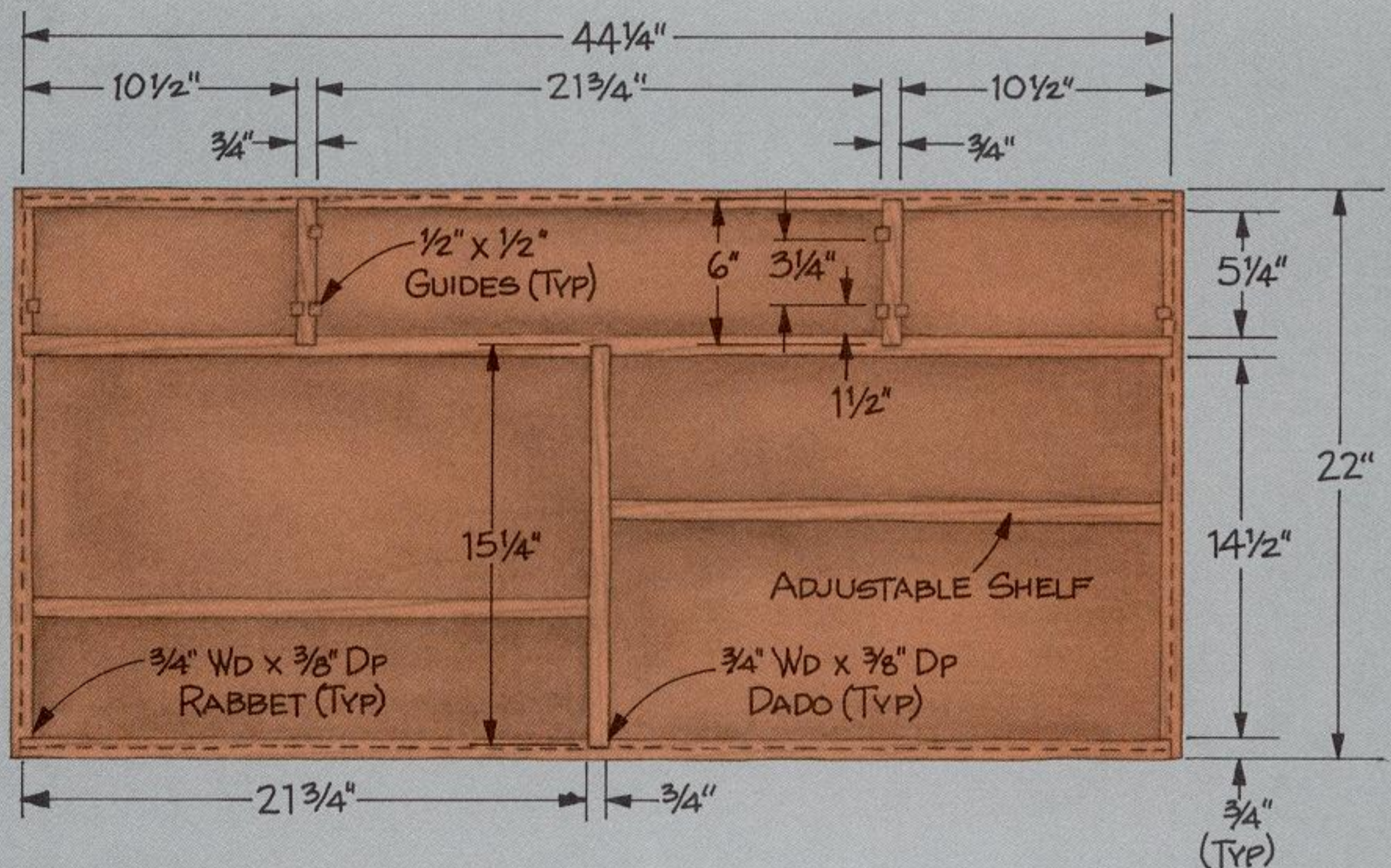

CASE LAYOUT

2 Cut the mortises and tenons in the top braces, legs, and feet. The top braces, legs, and feet form two frames which support the benchtop, as shown in the *Side View* and the *Leg Assembly Layout*. Tenons on the ends of the legs fit mortises in the feet and top braces. Cut the 1-inch-square, 1 1/2-inch-deep mortises first, then cut the tenons to fit them. Refer to Chapter 5 for instructions on how to make mortise-and-tenon joints.

3 Chamfer the ends of the top braces and feet. As shown in the *Side View* and the *Leg Assembly Layout*, the top corners of the feet and the bottom corners of the top braces are chamfered. Cut these chamfers on a table saw or a band saw.

4 Drill pilot holes in the top braces. The benchtop is secured to the leg assemblies with lag screws. Drill 7/16-inch-diameter pilot holes for these screws through the top braces, as shown in the *Leg Assembly Layout*. The precise location of these screws is not critical, but there should be at least three of them in each brace, and they should be evenly spaced along the length.

5 Assemble the legs, top braces, and feet. Dry assemble (without glue) the legs, top braces, and feet to be sure the mortise-and-tenon joints fit properly. When you're satisfied they do, finish sand the parts. Reassemble the parts with glue, let the glue dry, then sand all the surfaces clean and flush.

6 Cut the rabbets and dados in the plywood case parts. The cabinet case is a large plywood box held together with simple rabbets, dados, and grooves. Cut these joints:

- 3/4-inch-wide, 3/8-inch-deep rabbets in the top and bottom edges of the case sides, as shown in the *Case Side Layout*, to hold the case top and bottom
- 3/4-inch-wide, 3/8-inch-deep dado in the case sides to hold the case shelf
- 3/4-inch-wide, 3/8-inch-deep dados in the case top, bottom, and fixed shelf, as shown in the *Case Layout*, to hold the drawer dividers and cupboard divider
- 1/2-inch-wide, 1/4-inch-deep dados in the case sides to hold the drawer guides
- 1/2-inch-wide, 1/4-inch-deep grooves in the drawer dividers, as shown in the *Drawer Divider Layout*, to hold the drawer guides

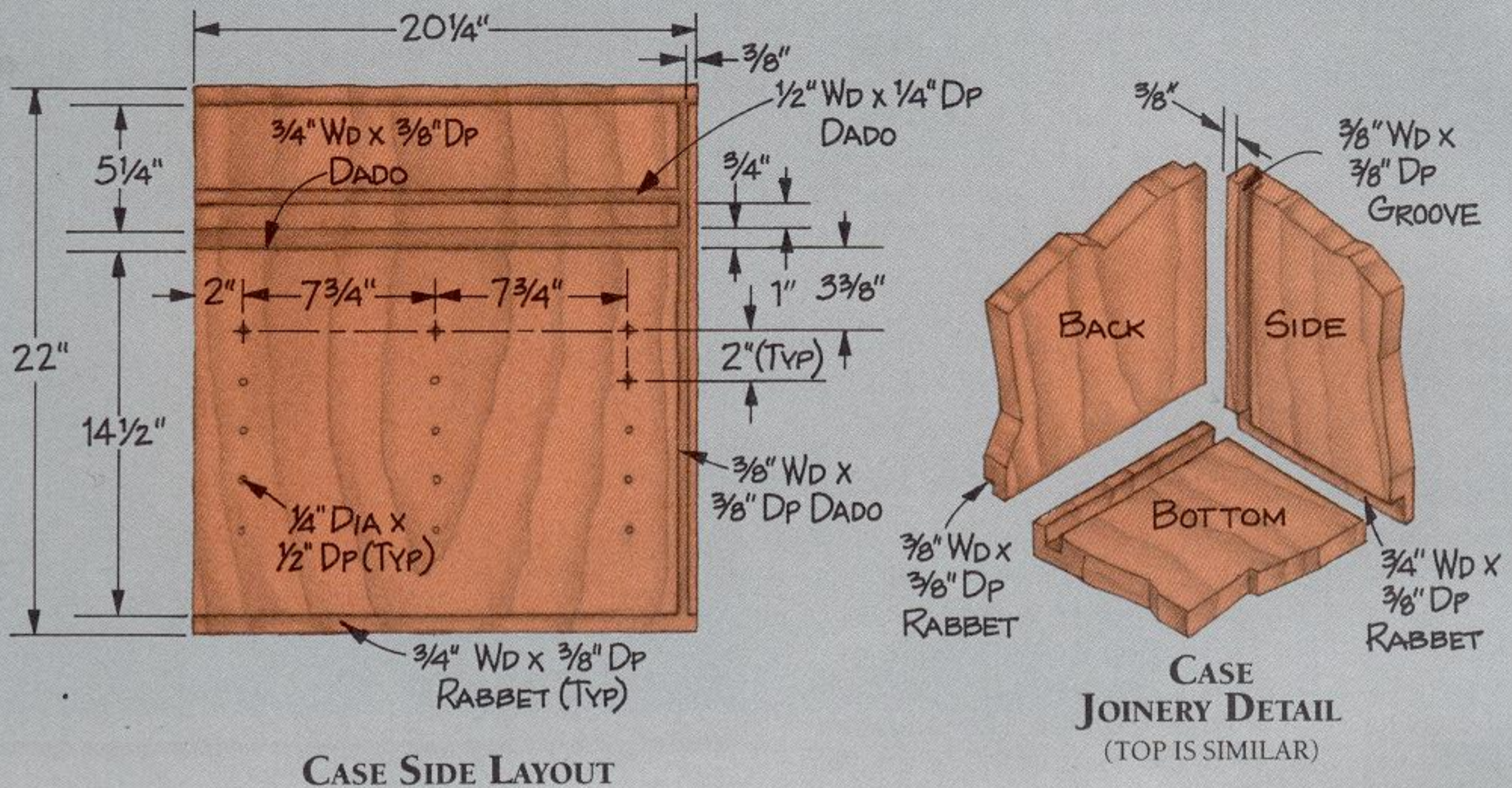

CASE SIDE LAYOUT

CASE
JOINERY DETAIL
(TOP IS SIMILAR)

- 3/8-inch-wide, 3/8-inch-deep grooves near the back edges of the case sides, top, and bottom, as shown in the *Case Joinery Detail*, to hold the case back
- 3/8-inch-wide, 3/8-inch-deep rabbets in the edges of the case back to fit the grooves in the case sides, top, and bottom

7 Drill holes in the case sides and cupboard divider. The adjustable shelves rest on support pins. These pins fit into holes inside the case. Drill 1/4-inch-diameter, 1/2-inch-deep holes in the case sides, as shown in the *Case Side Layout*, and 1/4-inch-diameter holes through the cupboard divider, as shown in the *Cupboard Divider Layout*.

8 Attach the drawer guides to the sides and dividers. The drawers slide in and out of the case on drawer guides — hardwood strips inlaid in the plywood. Sand the drawer guides smooth, then glue them in the 1/2-inch-wide dados and grooves in the case sides and drawer dividers.

9 Assemble the case. Finish sand all the plywood parts you've made so far. Assemble the fixed

shelf, drawer dividers, and cupboard divider with glue and #8 x 1 1/4-inch flathead wood screws. Countersink the heads of the screws flush with the surface of the wood. Let the glue set.

Lay the back, rear-side down, on a work surface. Place the divider assembly on top of it. Attach the case sides, top, and bottom to the back and divider assembly with glue and screws. Counterbore and countersink the screws, then cover the screw heads with plugs. Let the glue dry and sand all joints and plugs flush with the plywood surface. Be careful not to sand through the veneer.

10 Assemble the workbench. Finish sand the benchtop. Attach the case to the leg assemblies, driving #12 x 2-inch flathead wood screws through the case from the *inside* and into the legs. Use three screws for each leg, and space them evenly along the length of the leg. Fasten the benchtop to the leg assemblies by driving lag screws up through the top braces and into the underside of the benchtop.

11 Cut the mortises and tenons in the door rails and stiles. The rails and stiles on the frame-

and-panel doors are joined with haunched mortises and tenons. Cut $\frac{1}{4}$ -inch-wide, $\frac{3}{8}$ -inch-deep grooves in the inside edges of all the door rails and stiles, as shown in the *Door Frame Joinery Detail*. Then cut $\frac{1}{4}$ -inch-wide, $1\frac{1}{4}$ -inch-long, $1\frac{1}{4}$ -inch-deep mortises near both ends of each stile. Cut $\frac{1}{4}$ -inch-thick, $1\frac{1}{4}$ -inch-long tenons in the ends of the rails, then make a notch or "haunch" in the outer corner of each tenon to fit the mortise and groove in the stile. See page 75 for complete instructions on how to make a haunched mortise-and-tenon joint.

12 Assemble the doors. Finish sand the door parts, then assemble the rails and stiles with glue. As you fit the rails and stiles together, slide the panels into the grooves. However, *don't* glue the panels in place. Let them float in the grooves.

13 Hang the doors. The doors on the workbench swing on self-closing European-style hinges. These cabinet hinges offer several advantages over traditional butt hinges. They are much easier to install; you don't have to cut hinge mortises. They allow you to adjust the positions of the doors slightly even *after* you hang them. And they keep the doors closed without having to use an additional catch.

Mark the locations of the hinges on the case and door frames. Drill $1\frac{3}{8}$ -inch-diameter holes in the door frame stiles to mount the body of each hinge. Attach the hinges to the case and doors with screws, then adjust the position of the doors to open and shut without binding. The doors should completely cover the front edges of the case bottom and case shelf, and the outside edges of the end doors should be flush with the case sides. (SEE FIGURES 10-1 AND 10-2.)

Shut the door and mark the location of the door pulls. Drill pilot holes in the stiles and install the pulls.

14 Cut the drawer joinery. Like the case, the drawers are assembled with simple rabbets, dados, and grooves. Cut these joints:

- $\frac{9}{16}$ -inch-wide, $\frac{1}{4}$ -inch-deep grooves in the outside faces of the drawer sides to fit the drawer guides
- $\frac{1}{2}$ -inch-wide, $\frac{1}{4}$ -inch-deep rabbets in the inside front ends of the drawer sides to hold the drawer fronts
- $\frac{1}{2}$ -inch-wide, $\frac{1}{4}$ -inch-deep dados in the inside faces of the drawer sides, near the back ends, to hold the drawer backs
- $\frac{1}{4}$ -inch-wide, $\frac{1}{4}$ -inch-deep grooves in the inside faces of the drawer fronts, backs, and sides, near the bottom edges, to hold the drawer bottoms

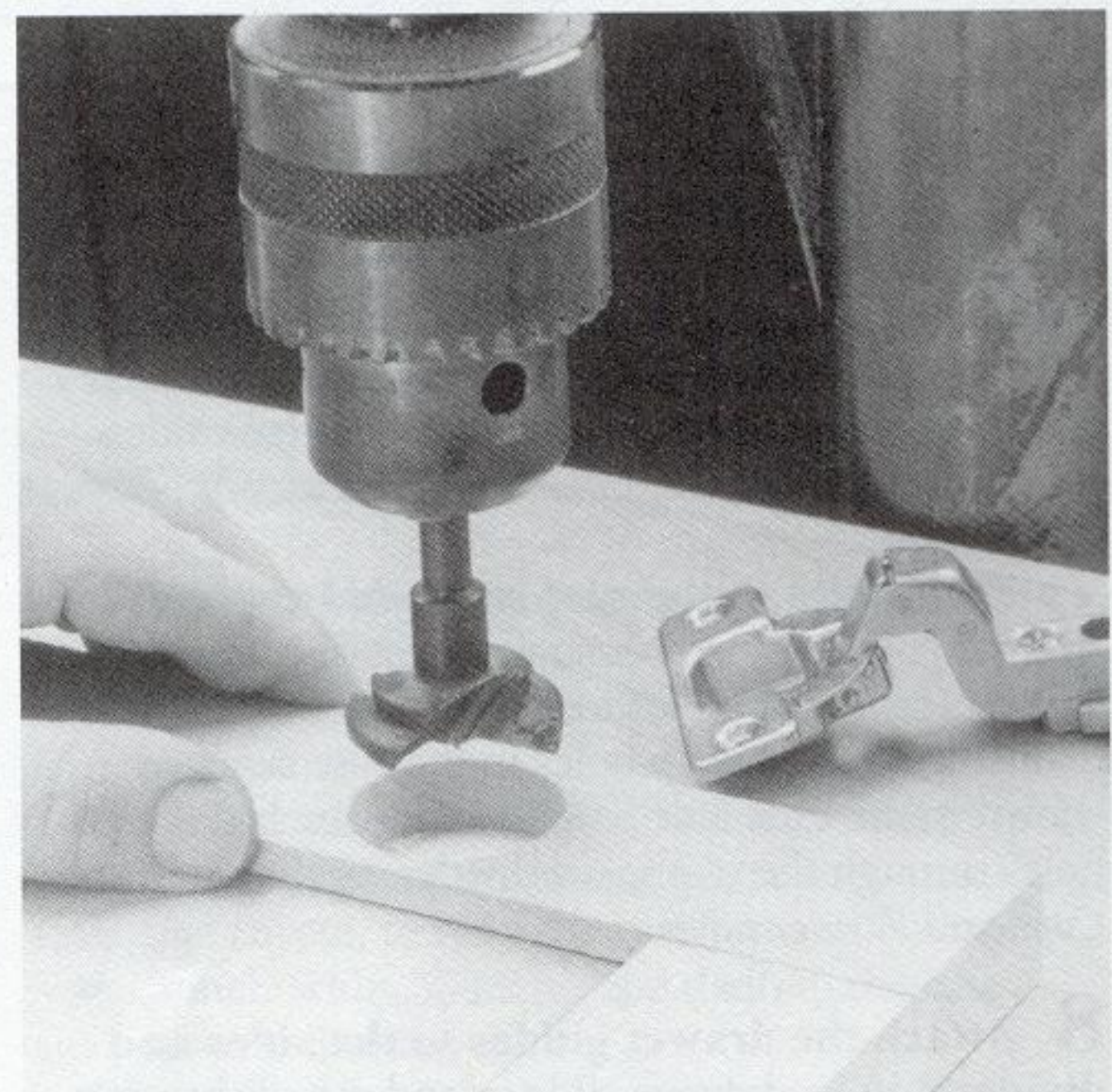
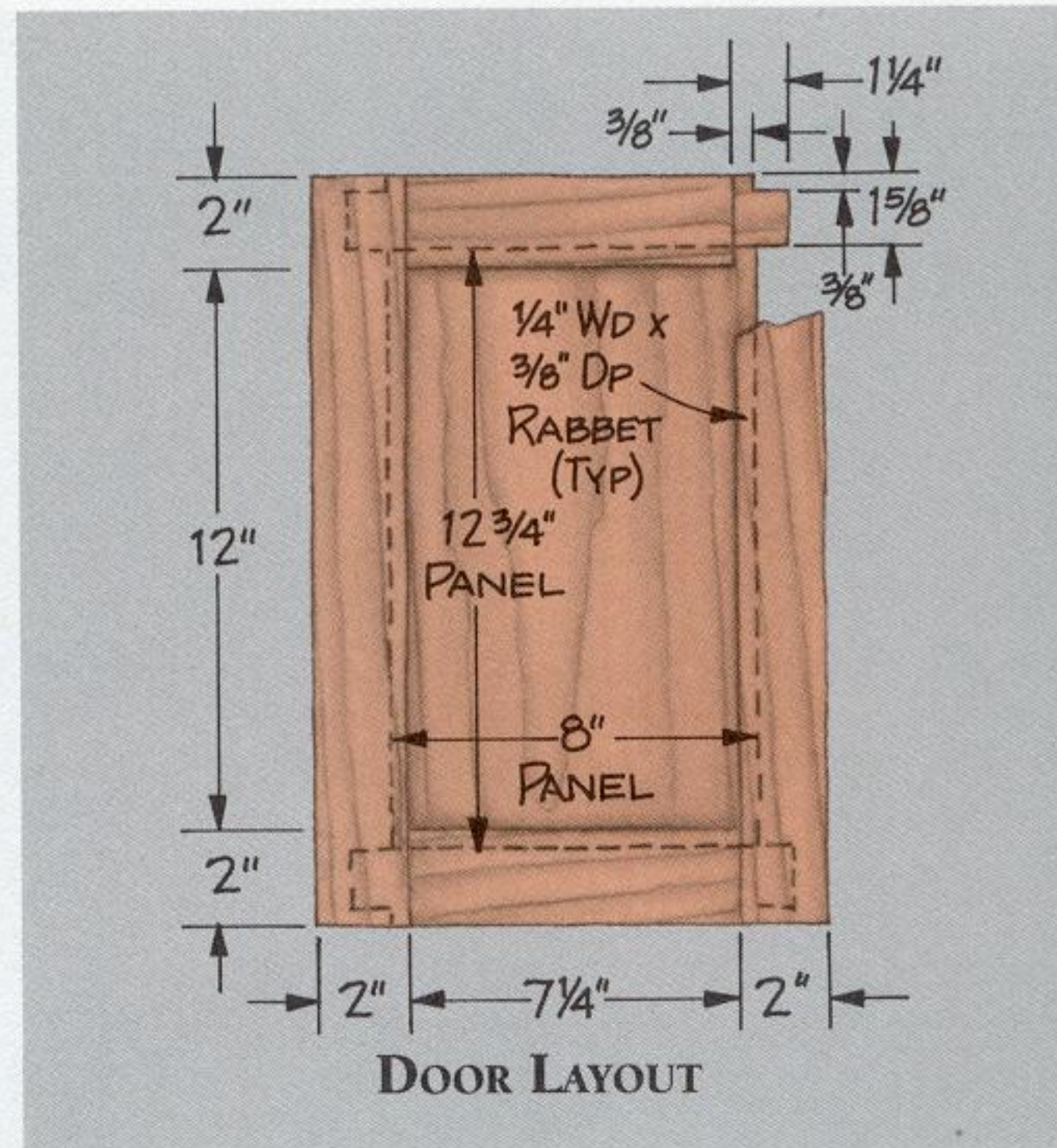

10-1 Using a large piloted Forstner bit, drill $1\frac{3}{8}$ -inch-diameter, $\frac{1}{2}$ -inch-deep holes in the door stiles to house the hinge bodies. These drill bits are available from most mail-order woodworking suppliers or any hardware dealer that sells European-style cabinet hinges.

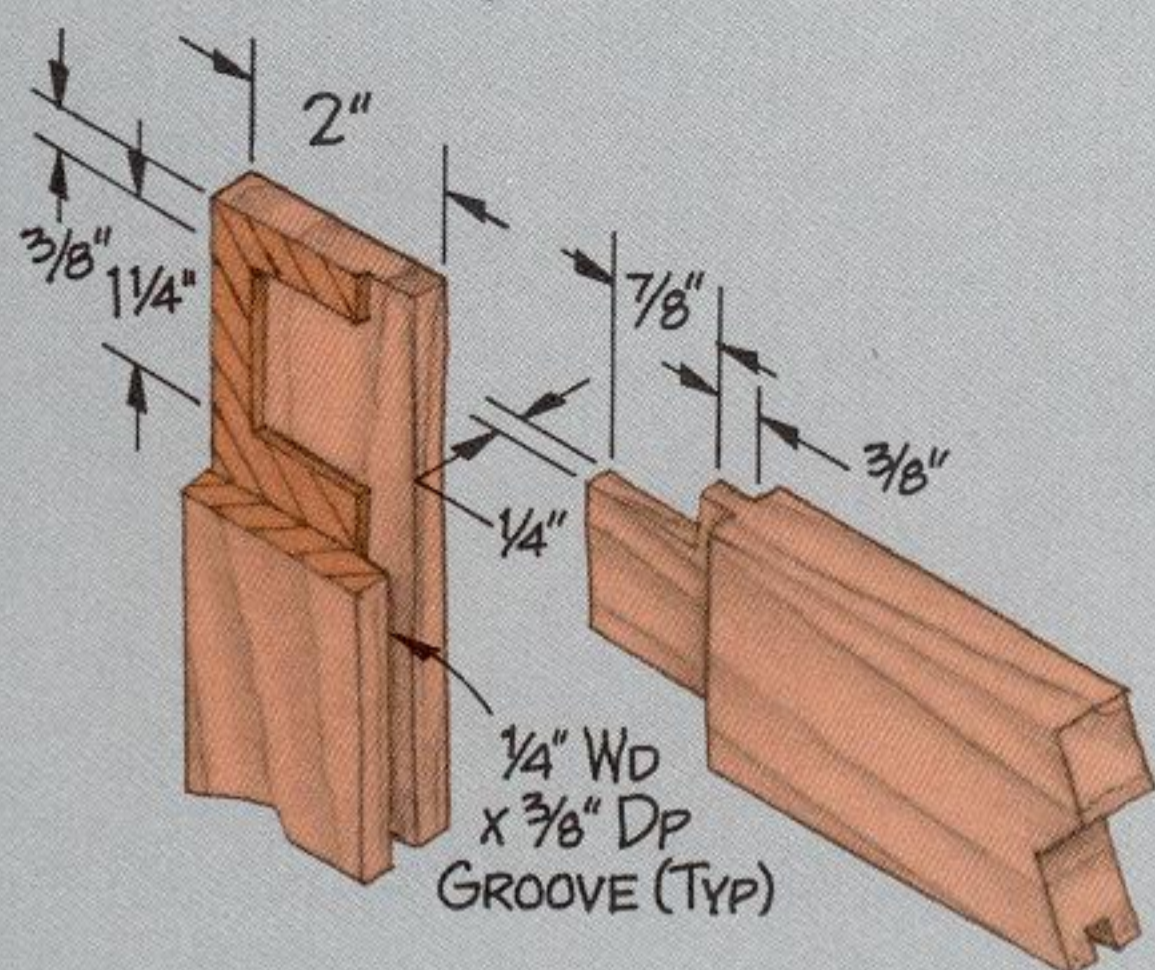

**DOOR FRAME
JOINERY DETAIL**

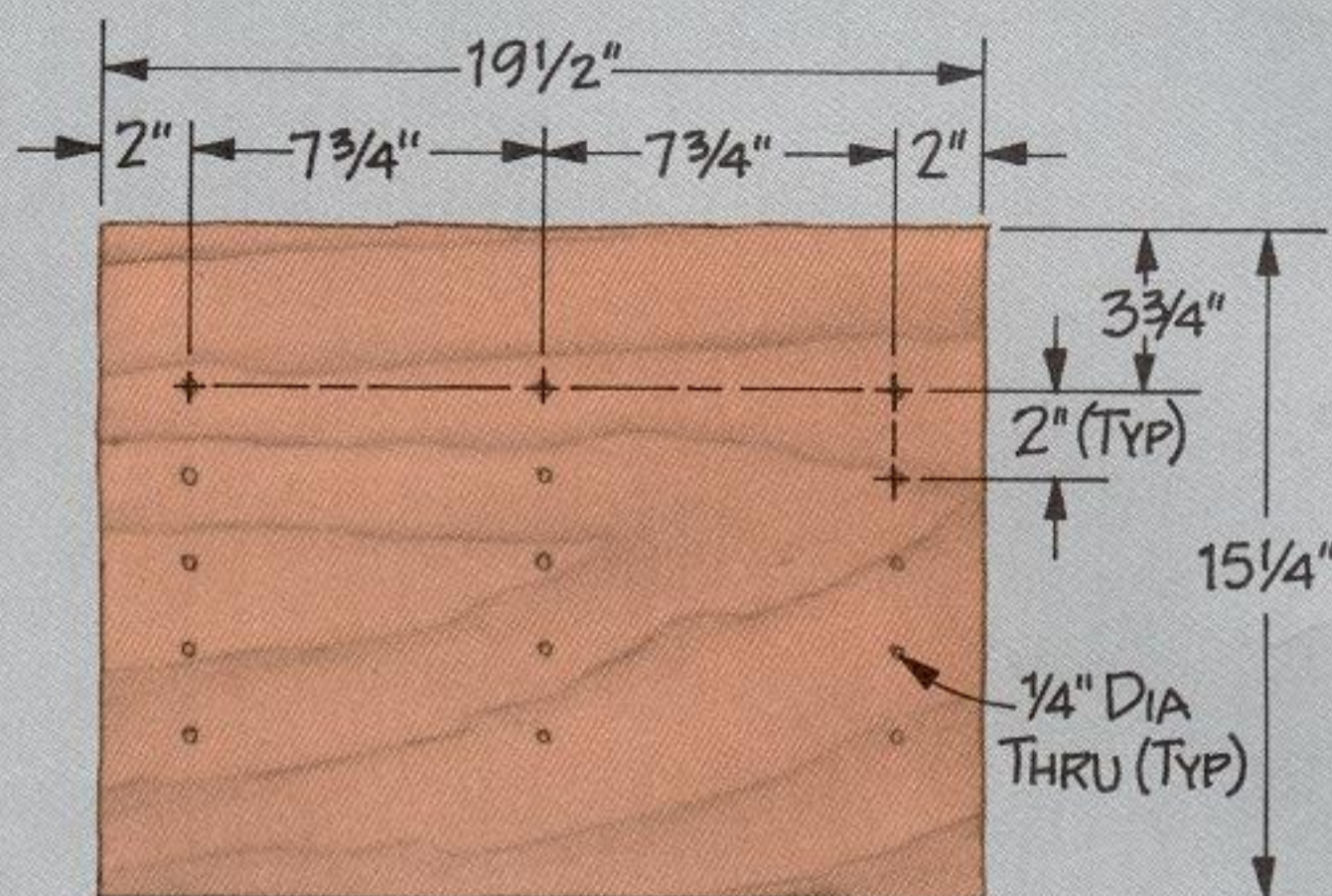

**CUPBOARD
DIVIDER LAYOUT**

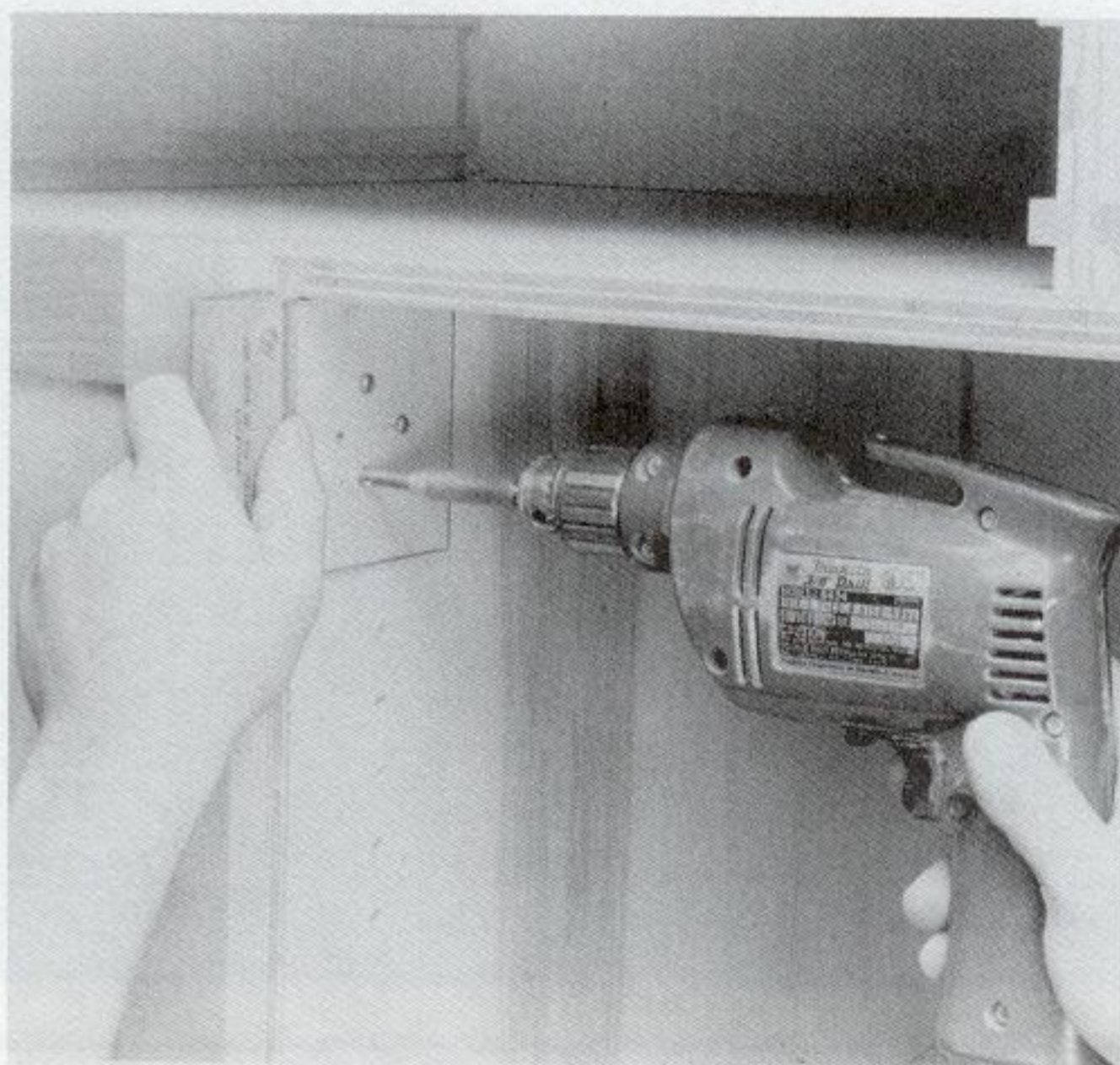

10-2 Use a template and a spring-loaded Vix bit to locate and bore the pilot holes for the screws that will hold the hinges to the case. (The Vix bit automatically centers small pilot holes inside the larger holes in the template.) Both the template and the bit are available from the same suppliers that offer the hinges.

15 Assemble and fit the drawers. Finish sand the parts of the drawers. Glue the sides, fronts, and backs together. Slide the bottoms into place as you assemble the other parts, but do *not* glue them in their grooves. Let them float. When the glue dries, reinforce the rabbet joints that hold the sides to the fronts with 1-inch brads. Sand all joints clean and flush.

Test the fit of the drawers in the case. The grooves in the sides should fit smoothly over the drawer guides, and the drawers should slide in and out of the case without binding. If a drawer sticks, inspect it carefully to determine which parts are rubbing. Plane a little stock off the offending part of the drawer and try again. Continue until all the drawers fit properly.



TRY THIS TRICK

If you have trouble deciding which drawer part is binding inside the case, lightly rub some chalk on the surfaces of the assembled drawer. Slide the drawer into place, then pull it out again. Inspect the inside of the case for chalk — this will tell you which part of the drawer is rubbing and where.

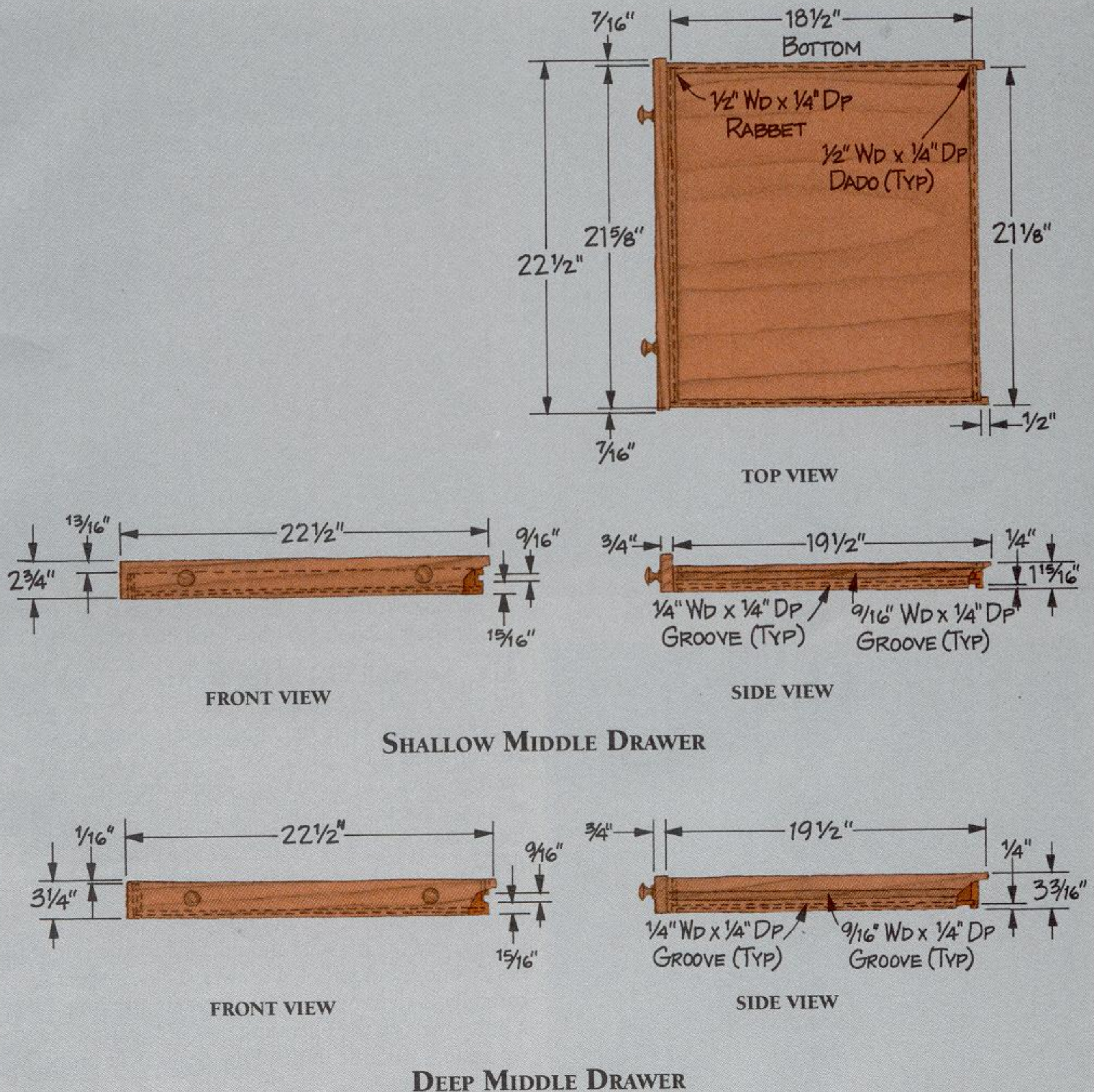

16 Attach the drawer faces. Slide the drawers into place in the case. Mark the locations of the pulls on the drawer faces and drill pilot holes for them. Finish sand the drawer fronts.

Hold each drawer face in place over the appropriate drawer front. Use the pilot holes in the face as guides to drill pilot holes through the drawer front. Apply

glue to the drawer front, then secure the face to the front. To hold the face while the glue dries, drive a screw through the pilot holes. Let the glue dry, then remove the screws and attach the pulls.

If the drawer fronts rub on one another — or on the doors — as you slide the drawers in and out of the cabinet, remove a little stock from the appropriate

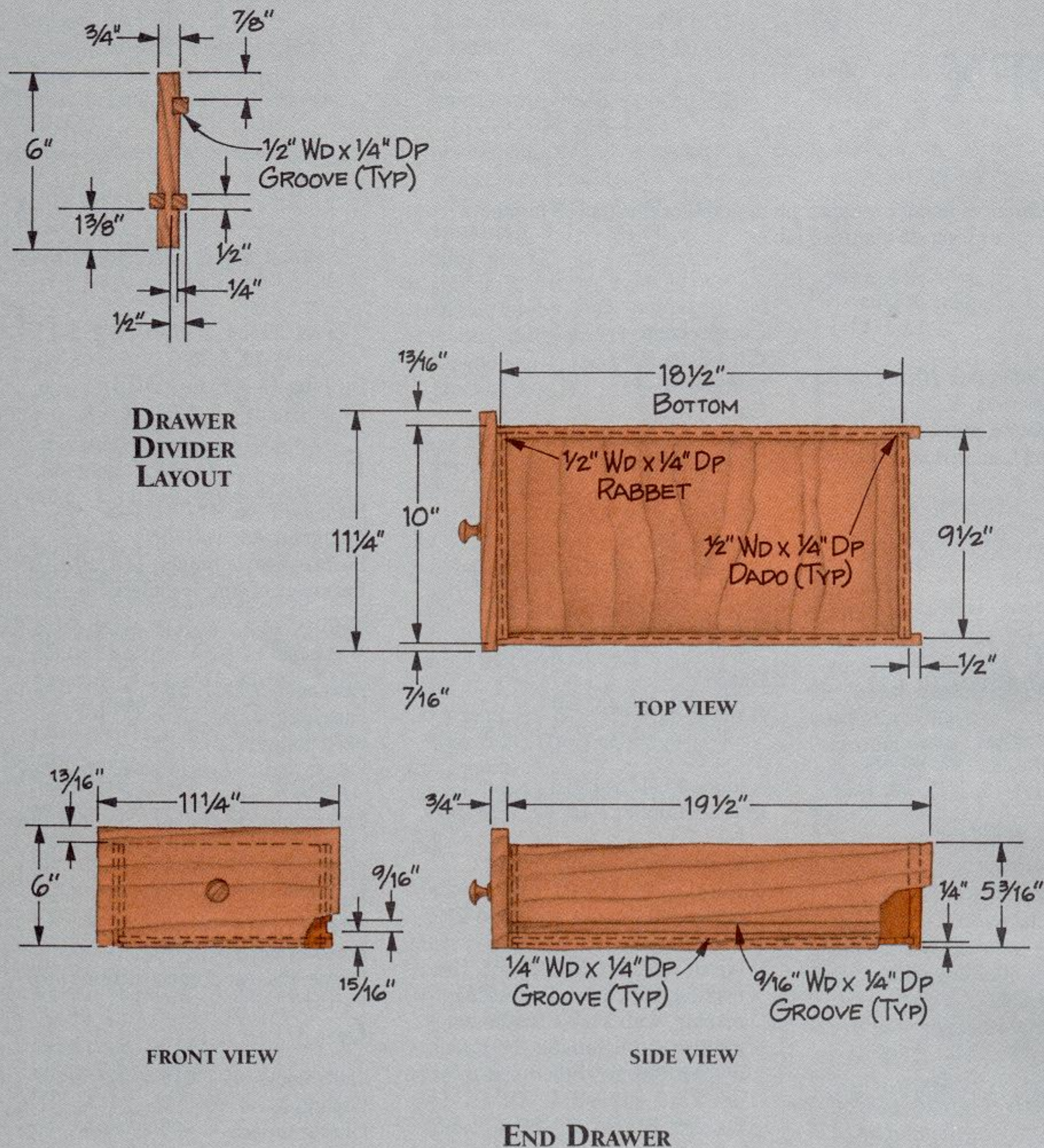

edge with a hand plane. When all the drawer fronts are installed, they should completely cover the front edges of the case, and their edges should be even with the top and sides of the case.

17 Finish the workbench. Remove the doors and drawers from the case, and remove the hardware

from the doors and drawers. Do any necessary touch-up sanding, then apply a finish to *all* wooden surfaces, inside and out. Use a penetrating finish that will be easy to repair, such as tung oil or Danish oil. Wax and buff the outside surfaces. Apply at least two coats of wax to the benchtop — this will help prevent glue from sticking to the surface.